

**NP6512/6612/  
7120/7130/7130F**

**SERVICE  
MANUAL**

**REVISION 0**

**Canon**

**AUG. 1999**

**FY8-13GB-000**

## **IMPORTANT**

THIS DOCUMENTATION IS PUBLISHED BY CANON INC., JAPAN, TO SERVE AS A SOURCE OF REFERENCE FOR WORK IN THE FIELD.

SPECIFICATIONS AND OTHER INFORMATION CONTAINED HEREIN MAY VARY SLIGHTLY FROM ACTUAL MACHINE VALUES OR THOSE FOUND IN ADVERTISING AND OTHER PRINTED MATTER.

ANY QUESTIONS REGARDING INFORMATION CONTAINED HEREIN SHOULD BE DIRECTED TO THE COPIER SERVICE DEPARTMENT OF THE SALES COMPANY.

THIS DOCUMENTATION IS INTENDED FOR ALL SALES AREAS, AND MAY CONTAIN INFORMATION NOT APPLICABLE TO CERTAIN AREAS.

***COPYRIGHT © 1999 CANON INC.***

***Printed in Japan***

***Imprimé au Japon***

Use of this manual should be strictly supervised to avoid disclosure of confidential information.
---

Prepared by

OFFICE IMAGING PRODUCTS TECHNICAL SUPPORT DIVISION

**CANON INC.**

5-1, Hakusan 7-chome, Toride-shi, Ibaraki 302-8501 Japan

# INTRODUCTION

This service manual has been prepared for NP6512, NP6612, NP7120, NP7130, and NP7130F, providing basic information used for servicing the machines in the field so as to ensure their quality and performance.

This service manual consists of the following chapters:

- Chapter 1 *General Description* introduces the machine's features, specifications, names of parts, and how originals are reproduced.
- Chapter 2 *Basic Operation* explains how copies are made on a step-by-step basis.
- Chapter 3 *Exposure System* discusses the principles of operation used for the machine's exposure system. It also explains the timing at which exposure-related mechanisms are operated, and shows how they may be disassembled/assembled and adjusted.
- Chapter 4 *Image Formation System* discusses the principles of operation used for the machine's image formation system. It also explains the timing at which image formation-related mechanisms are operated, and shows how they may be disassembled/assembled and adjusted.
- Chapter 5 *Pick-Up/Feeding System* discusses the principles of operation used for the machine's pickup/feeding system. It also explains the timing at which pickup/feeding-related mechanisms are operated, and shows how they may be disassembled/assembled and adjusted.
- Chapter 6 *Fixing System* discusses the principles of operation used for the machine's fixing system. It also explains the timing at which fixing-related mechanisms are operated, and shows how they may be disassembled/assembled and adjusted.
- Chapter 7 *Externals/Auxiliary Mechanisms* discusses the principles of operation used for the machine's externals/auxiliary mechanisms. It also explains the timing at which auxiliary mechanism-related mechanisms are operated, and shows how they may be disassembled/assembled and adjusted.
- Chapter 8 *ADF* explains the principles of operation of the ADF in view of electrical and mechanical functions and in relation to their timing of operation. It also shows how the unit may be disassembled/assembled and adjusted.
- Chapter 9 *Installation* introduces requirements for the site of installation, and shows how the machine may be installed using step-by-step instructions.
- Chapter 10 *Maintenance and Servicing* provides tables of periodically replaced parts and consumables/durables and scheduled servicing charts.
- Chapter 11 *Troubleshooting* provides tables of maintenance/inspection, standards/adjustments, and problem identification (image fault/malfunction).

Appendix contains a general timing chart and general circuit diagrams.

---

The following rules apply throughout this Service Manual:

1. Each chapter contains sections explaining the purpose of specific functions and the relationship between electrical and mechanical systems with reference to the timing of operation.

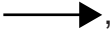
In the diagrams,  represents the path of mechanical drive—where a signal name accompanies the symbol , the arrow indicates the direction of the electric signal.

The expression “turn on the power” means flipping on the power switch, closing the front door, and closing the delivery unit door, which results in supplying the machine with power.

2. In the digital circuits, ‘1’ is used to indicate that the voltage level of a given signal is “High,” while ‘0’ is used to indicate “Low.” (The voltage value, however, differs from circuit to circuit.)

In practically all cases, the internal mechanisms of a microprocessor cannot be checked in the field. Therefore, the operations of the microprocessors used in the machines are not discussed: they are explained in terms of from sensors to the input of the DC controller PCB and from the output of the DC controller PCB to the loads.

The descriptions in this Service Manual are subject to change without notice for product improvement or other reasons, and major changes will be communicated in the form of Service Information bulletins.

All service persons are expected to have a good understanding of the contents of this Service Manual and all relevant Service Information bulletins and be able to identify and isolate faults in the machine.

- This service manual covers the models shown in the following table. Be sure to have a good understanding of the difference from model to model before referring to this manual.

Model	Type code	Default ratio	ADF as standard	Cassette
NP6512	TWA	2R2E		250 sheets
NP6612	TXA	2R2E	√	250 sheets
NP7120	PUB	2R2E		Universal
NP7120	PUC	2R2E		Universal
NP7130	NVF	3R1E		500 sheets
NP7130	PTZ	2R2E		500 sheets
NP7130F	NVH	3R1E	√	500 sheets

The notation “√” indicates that the item in question is available.



# CONTENTS

---

## CHAPTER 1 GENERAL DESCRIPTION

---

I. FEATURES .....	1-1	IV. USING THE MACHINE .....	1-13
II. SPECIFICATIONS .....	1-2	A. Control Panel .....	1-13
A. Copier .....	1-2	B. User mode .....	1-15
B. ADF .....	1-6	V. ROUTINE MAINTENANCE BY THE	
III. NAMES OF PARTS .....	1-8	USER .....	1-16
A. External View .....	1-8	VI. IMAGE FORMATION .....	1-19
B. Cross Section .....	1-11	A. Outline .....	1-19

---

## CHAPTER 2 BASIC OPERATION

---

I. BASIC OPERATIONS .....	2-1	D. Controlling the Main	
A. Functional Construction .....	2-1	Motor (M1) .....	2-5
B. Outline of Electrical		E. Inputs to and Outputs from the	
Circuitry .....	2-2	DC Controller .....	2-7
C. Basic Sequence of			
Operations .....	2-3		

---

## CHAPTER 3 EXPOSURE SYSTEM

---

I. OPERATIONS .....	3-1	II. EXPOSURE SYSTEM .....	3-9
A. Outline .....	3-1	A. Controlling the Scanning	
B. Varying the Reproduction		Lamp .....	3-9
Ratio .....	3-2	III. DISASSEMBLY/ASSEMBLY .....	3-13
C. Lens Drive System .....	3-3	A. Scanner Drive Assembly .....	3-14
D. Scanner Drive System .....	3-4	B. Lens Drive Assembly .....	3-32
		C. Exposure System .....	3-38

---

## CHAPTER 4 IMAGE FORMATION SYSTEM

---

- |   |   |
|---|---|
| I. IMAGE FORMATION SYSTEM ... 4-1   | II. DEVELOPING ASSEMBLY<br>/CLEANING ASSEMBLY ..... 4-27  |
| A. Outline ..... 4-1  | A. Outline ..... 4-27                                     |
| B. Timing Chart for the Image<br>Formation System ..... 4-3                       | B. Detecting the Level of<br>Toner ..... 4-28             |
| C. Primary Charging Roller Bias<br>Control ..... 4-4                              | C. Detecting Waste Toner ..... 4-30                       |
| D. Controlling the Transfer Roller<br>Bias ..... 4-9                              | D. Primary Charging Roller<br>Cleaning Control ..... 4-31 |
| E. Controlling the Developing/<br>Separation Static Eliminator<br>Bias ..... 4-12 | III. DISASSEMBLY/ASSEMBLY ..... 4-33                      |
| F. Measuring the Density of<br>Originals ..... 4-18                               | A. Drum Unit ..... 4-34                                   |
| G. Controlling the Pre-Exposure<br>Lamp ..... 4-24                                | B. Transfer Charging<br>Assembly ..... 4-38               |
| H. Controlling the Side Blanking<br>Mechanism ..... 4-26                          | C. Blank Exposure ..... 4-39                              |
|   | D. Developing Assembly ..... 4-43                         |

---

## CHAPTER 5 PICK-UP/FEEDING SYSTEM

---

- |   |   |
|---|---|
| I. PICKUP/FEEDING SYSTEM..... 5-1                 | II. DISASSEMBLY/ASSEMBLY ..... 5-13           |
| A. Outline ..... 5-1                              | A. Pickup Assembly ..... 5-14                 |
| B. Controlling the Pickup<br>Roller ..... 5-2     | B. Multifeeder Assembly ..... 5-21            |
| C. Controlling the Movement of<br>Paper ..... 5-6 | C. Feeding Assembly ..... 5-24                |
| D. Detecting Jams ..... 5-8                       | D. Registration Roller<br>Assembly ..... 5-25 |
|   | E. Delivery Assembly ..... 5-30               |

---

## CHAPTER 6 FIXING SYSTEM

---

- |  |                                    |
|--|------------------------------------|
| I. OPERATIONS ..... 6-1                            | II. DISASSEMBLY/ASSEMBLY ..... 6-9 |
| A. Outline ..... 6-1                               | A. Fixing Assembly ..... 6-10      |
| B. Controlling the Fixing<br>Temperature ..... 6-3 |                                    |



---

## CHAPTER 7 EXTERNALS/AUXILIARY MECHANISMS

---

- I. FANS ..... 7-1
- II. POWER SUPPLY SYSTEM ..... 7-3
  - A. Outline of the Power Supply System ..... 7-3
  - B. Power Supply Circuit ..... 7-4
  - C. Detecting an Error on the Composite Power Supply PCB ..... 7-6
  - D. Protecting the Power Supply Circuit ..... 7-6
- III. DISASSEMBLY/ASSEMBLY ..... 7-7
  - A. External Covers ..... 7-8
  - B. Control Panel ..... 7-15
  - C. Copyboard Glass ..... 7-16
  - D. Main Motor/Main Drive Assembly ..... 7-17
  - E. Electrical System ..... 7-21

---

## CHAPTER 8 ADF

---

- I. ADF ..... 8-1
  - A. Outline ..... 8-1
  - B. Basic Construction ..... 8-2
  - C. Basic Operations ..... 8-4
  - D. Detecting an Original ..... 8-6
  - E. Pickup Operation ..... 8-8
  - F. Delivery ..... 8-12
  - G. Controlling the Pickup Motor ..... 8-14
  - H. Controlling the Belt Motor .. 8-15
  - I. Detecting Original Jams .... 8-16
  - J. Power Supply ..... 8-17
- II. DISASSEMBLY/ASSEMBLY ..... 8-18
  - A. Removing the ADF ..... 8-19
  - B. External Covers ..... 8-21
  - C. Drive System ..... 8-23
  - D. Feeding System ..... 8-26
  - E. Electrical System ..... 8-33

---

## CHAPTER 9 INSTALLATION

---

- I. SELECTING THE SITE ..... 9-1
- II. UNPACKING AND INSTALLATION ..... 9-2
  - A. Unpacking and Installation .... 9-2
  - B. Placing Copy Paper ..... 9-18
- III. MOVING THE MACHINE ..... 9-21

---

## CHAPTER 10 MAINTENANCE AND SERVICING

---

- I. PERIODICALLY REPLACED PARTS ..... 10-1
- II. DURABLES AND CONSUMABLES ..... 10-1
- III. SCHEDULED SERVICING ..... 10-1

---

## CHAPTER 11 TROUBLESHOOTING

---

I. MAINTENANCE AND INSPECTION .....	11-3	B. Faulty Feeding .....	11-80
A. Image Adjustment Basic Procedure .....	11-3	VI. ARRANGEMENT AND FUNCTIONS OF ELECTRICAL PARTS .....	11-81
B. Points to Note for Servicing .....	11-4	A. Sensors and Solenoids ....	11-81
II. STANDARDS AND ADJUSTMENTS .....	11-5	B. Switches .....	11-82
A. Mechanical .....	11-5	C. Lamp, Heater, Motor, Etc.	11-83
B. ADF .....	11-30	D. PCBs .....	11-84
C. Electrical .....	11-41	E. ADF .....	11-85
III. TROUBLESHOOTING IMAGE FAULTS .....	11-52	F. Variable Resistors (VR) and Check Pins by PCB .....	11-86
A. Making Initial Checks .....	11-52	VII. SERVICE MODE .....	11-88
B. Sample Image Faults .....	11-56	A. Outline .....	11-88
C. Troubleshooting Image Faults .....	11-57	B. Using Service Mode .....	11-88
IV. TROUBLESHOOTING MALFUNCTIONS .....	11-65	C. Adjustment Mode (30) .....	11-91
A. Troubleshooting Malfunctions .....	11-65	D. Operation/Inspection Mode (40) .....	11-92
V. TROUBLESHOOTING FEEDING PROBLEMS .....	11-77	E. Machine Settings Mode (50) .....	11-93
A. Copy Paper Jam .....	11-77	F. Counter Mode (60) .....	11-93
		VIII. SELF DIAGNOSIS .....	11-94

---

## APPENDIX

---

A. GENERAL TIMING CHART .....	A-1	I. SENSOR CIRCUIT DIAGRAM .....	A-32
B. SIGNALS AND ABBREVIATIONS .....	A-3	J. NOISE FILTER CIRCUIT DIAGRAM .....	A-33
C. GENERAL CIRCUIT DIAGRAM .....	A-5	K. HIGH VOLTAGE CONTACT CIRCUIT DIAGRAM .....	A-34
D. DC CONTROLLER CIRCUIT DIAGRAM .....	A-7	L. BLANK EXPOSURE (front) CIRCUIT DIAGRAM .....	A-35
E. ADF CONTROLLER CIRCUIT DIAGRAM .....	A-15	M. BLANK EXPOSURE (rear) CIRCUIT DIAGRAM .....	A-36
F. COMPOSITE POWER SUPPLY CIRCUIT DIAGRAM .....	A-19	N. PRE-EXPOSURE CIRCUIT DIAGRAM .....	A-37
G. CONTROL PANEL CIRCUIT DIAGRAM .....	A-29	O. SPECIAL TOOLS .....	A-38
H. AE SENSOR CIRCUIT DIAGRAM .....	A-31	P. SOLVENTS/OILS .....	A-39

---

# CHAPTER 1

---

## GENERAL DESCRIPTION

---

This chapter provides specifications of the machine, instructions on how to operate the machine, and an outline of copying process.

I. FEATURES .....	1-1	IV. USING THE MACHINE .....	1-13
II. SPECIFICATIONS .....	1-2	A. Control Panel .....	1-13
A. Copier .....	1-2	B. User mode .....	1-15
B. ADF .....	1-6	V. ROUTINE MAINTENANCE BY THE	
III. NAMES OF PARTS .....	1-8	USER .....	1-16
A. External View .....	1-8	VI. IMAGE FORMATION .....	1-19
B. Cross Section .....	1-11	A. Outline .....	1-19



## I. FEATURES

### 1. Personal Copier with a Zoom Function and a Fixed Copyboard

- You can choose either a default enlargement/reduction ratio or any ratio between 70% and 141% in 1% increments.

### 2. Ecology-Conscious

- The use of a roller charging method has resulted in a considerable reduction of ozone: 0.01 ppm or less on the average, 0.02 ppm or less at maximum (1/100 to 1/1000 compared with existing Canon machines).

### 3. SURF Fixing Assembly

- The wait time is 0 sec (at 20°C room temperature), enabling speedy copying work immediately after power-on.

### 4. Various Paper Sizes

- The paper may be between A4 (LGL) and A5 (STMT)(\*Using the universal cassette).
- In manual feed mode, paper may be as large as A4 (LGL) or as small as a business card.

### 5. Large Paper Source

- The source of paper may contain as many as 550 sheets of paper (500-sheet cassette type).

### 6. Separate top unit.

- The machine's top unit may be opened to make jam removal easy.

### 7. ADF Type

- Continuous copying is possible with the use of the ADF.

## II. SPECIFICATIONS

### A. Copier

#### 1. Type

Item	Descriptions
Body	Desk top
Copyboard	Fixed
Source of light	Halogen lamp (80 V/110 W for 120V-model; 150 V/160 W for 220/240 V-model)
Lens	Fixed focal point lens
Photosensitive medium	OPC drum (24-mm dia.)

**Table 1-201**

#### 2. Mechanisms

Item	Descriptions
Reproduction	Indirect static reproduction
Charging	Roller (direct charging)
Exposure	Slit (moving light source)
Copy density adjustment	Auto or manual
Development	Dry (toner projection)
Pickup	Cassette (1 pc.) Multifeeder
Separation	Curvature separation + static eliminator
Fixing	Flat heater
Cleaning	Blade
Original orientation	Center reference (copyboard)

**Table 1-202**

### 3. Performance

Item	Descriptions
Original type	Sheet, book, 3-D object (2kg max.)
Maximum original size	A4 (297 × 210 mm)/LGL (216 × 356 mm)
Reproduction ratio	Inch/AB-configuration: 2R2E Inch-configuration: 3R1E
Zoom	70% to 141% (in 1% increments)
Wait time	0 sec (at 20°C room temperature)
First copy time	10 sec or less (at 20°C room temperature; Direct, non-AE, from the cassette)
Continuous copying	100 (max.)
Copy size	A4/LGL (297 × 210 mm/216 × 356 mm max.) Business card (90 × 55 mm, min.)
Copy paper type	Cassette: Plain paper (64 to 80 g/m <sup>2</sup> ), tracing paper (SM-1, A4R/B5R), colored paper, recycled paper (64 to 80 g/m <sup>2</sup> ; A4R/B5R), eco paper (80 g/m <sup>2</sup> ; A4R) Manual Feeder: Plain paper (52 to 128 g/m <sup>2</sup> ), tracing paper (SM-1, GNT-80* <sup>1</sup> ; A4R/B5R), transparency* <sup>1,*3</sup> (A4R/LTRR* <sup>2</sup> ), colored paper, business card (200 g/m <sup>2</sup> or less), label sheet* <sup>1</sup> (A4R/LTRR), recycled paper (64 to 80 g/m <sup>2</sup> ; A4R/B5R), eco paper (80 g/m <sup>2</sup> ; A4R), postcard* <sup>2</sup> Double-Sided/Overlay Copying* <sup>4</sup> : Plain paper (64 to 128 g/m <sup>2</sup> ), colored paper, business card (200 g/m <sup>2</sup> or less), recycled paper (64 to 80 g/m <sup>2</sup> ; A4R/B5R), eco paper (80 g/m <sup>2</sup> ; A4R), postcard
Cassette	With claws Universal cassette (250 sheets of 80 g/m <sup>2</sup> paper; A4/LGL to A5/STMT) 250-sheet cassette (250 sheets of 80 g/m <sup>2</sup> ) 500-sheet cassette (500 sheets of 80 g/m <sup>2</sup> )
Multifeeder tray	5 mm deep (approx.; 50 sheets of 80 g/m <sup>2</sup> )
Copy tray	100 sheets (A4; 80 g/m <sup>2</sup> )
Non-image width	Leading edge: 2.0 ± 1.5 mm (Direct; 4.0 mm or less otherwise) Left/right: 0.0 + 2.0, -0.0 mm (0 + 4.0, -0.0 mm for LTR)
Auto power-off	Provided (5 min, approx.; fixed)* <sup>5</sup>

**Table 1-203**

- \*1. Applies only to single pickup if the multifeeder is used.
- \*2. Applies only to vertical feeding.
- \*3. Upon delivery, be sure to remove each from the copy tray.
- \*4. Be sure to remove any curling before feeding for a second time.
- \*5. If stopped because paper ran out during copying operation, 1 hr.

4. Others

Item	Descriptions
Operating condition	
Temperature	7.5°C to 32.5°C/45.5°F to 90.5°F
Humidity	5% to 85% RH
Atmospheric pressure	607.95 to 1013.25 hPa (0.6 to 1 atm)
Power source	120 V 60 Hz    220/240 V 50 Hz
Serial number	NVFxxxxx    PTZxxxxx NVHxxxxx    PUBxxxxx PUCxxxxx TWAxxxxx TXAxxxxx
Maximum power consumption	0.9 kW or less Standby: 1.2 W (approx.; about 5 min; reference only) Copying: 0.4 kWh (approx.; reference only)
Noise	Standby: - (sound power level by ISO) Copying: 66 dB or less (sound power level by ISO)
Ozone	0.01 ppm or less (average; 0.02 ppm or less, max.)
Dimensions (WxDxH)	Copyboard Type 484.9 × 448.2 × 297.5 mm <sup>*1</sup> /329.0 mm <sup>*2</sup> 19.1 in. × 17.6 in. × 11.7 in. <sup>*1</sup> /13.0 in. <sup>*2</sup> ADF Type 484.9 × 448.2 × 358.3 mm <sup>*1</sup> /389.8 mm <sup>*2</sup> 19.1 in. × 17.6 in. × 14.1 in. <sup>*1</sup> /15.3 in. <sup>*2</sup>
Weight (including the cassette)	Copyboard Type 20.6 kg <sup>*1</sup> /45.3 lb <sup>*1</sup> , 22.5 kg <sup>*2</sup> /49.5 lb <sup>*2</sup> ADF Type 24.4 kg <sup>*1</sup> /53.7 lb <sup>*1</sup> , 26.3 kg <sup>*2</sup> /57.9 lb <sup>*2</sup>
Consumables	Copy paper: Keep wrapped, and protect against humidity. Toner: Avoid direct sunlight, and store at 40°C/104°F, 85% or less.

Table 1-204

\*1. 250-sheet cassette type

\*2. 500-sheet cassette type



## 5. Default Ratios

Item	2R2E (Inch/AB-configuration)	3R1E (Inch-configuration)
Direct	1:1.000	1:1.000
Reduce I	1:0.707	1:0.707
Reduce II		1:0.786
Reduce III	1:0.816	
Reduce IV		1:0.860
Enlarge I	1:1.154	
Enlarge II	1:1.414	1:1.414

**Table 1-205**

## 6. Copying Speed

Copying speed at Direct	Reproduction ratio	Copy size	Number of copies (Multifeeder*1) (copies/min)
13	Direct  Reduce I (70.7%) Reduce II (78.6%) Reduce IV (86.0%) Enlarge II (141.4%)	LTRR	13 (9)
		LGL	11 (8)
		STMTR	13 (9)
		MIN	13 (9)
		LGL → LTRR	13 (9)
		MARJIN	13 (9)
		MAX	10 (9)
12	Direct  Reduce I (70.7%) Reduce III (81.6%) Enlarge I (115.4%) Enlarge II (141.4%)	A4R	12 (9)
		B5R	12 (9)
		A5R	12 (9)
		A4R → A5R	12 (9)
		B5R → A5R	12 (9)
		B5R → A4R	12 (9)
		A5R → A4R	10 (9)

**Table 1-206**

- \*1. The number of copies starting with the pickup operation that follows the delivery of the 19th copy in a continuous copying job. (See p.5-5)

The specifications are subject to change for product improvement.

**B. ADF**

Item	Descriptions
Original pickup	Auto pickup/delivery
Original orientation	Face-down
Original position	Center reference
Original separation	Top separation
Original type	Single-sided (50 to 128 g/m <sup>2</sup> ) A5 (STMT) to A4R (LTRR), LGL Length: 139.7 to 355.6 mm (feeding direction) Width: 139.7 to 215.9 mm
Stack	30 sheets (80 g/m <sup>2</sup> or less; about 3 mm in height)
Original processing mode	Single-sided original to single-sided copy
Original size detection	Yes (in feeding direction)
Mixed original sizes	No
Original detection	Yes
Original feeding speed	446 mm/sec
Communication with host	IPC
Dimensions	Width: 474 mm/18.7 in. (659 mm/25.9 in. with the tray open) Depth: 394 mm/15.5in. Height: 74 mm/2.9 in. (216 mm/8.5 in. with the tray open)
Weight	5 kg/11 lb (approx.)
Power source	24 VDC and 5 VDC (from the host)
Maximum power consumption	40 W or less
Operating environment	Temperature: same as the host Humidity: same as the host

**Table 1-207**

- \*1. The following may not be used as an original:
- Sheet with a staple, clip, or glue.
  - Sheet with a cut, hole, or tear.
  - Sheet with holes for binding.
  - Sheet with a carbon back.
  - Sheet with a cut-and-paste piece.
  - Sheet with curling, bending, or wrinkling.

The specifications are subject to change for product improvement.

### III. NAMES OF PARTS

#### A. External View

##### 1. Copyboard Type

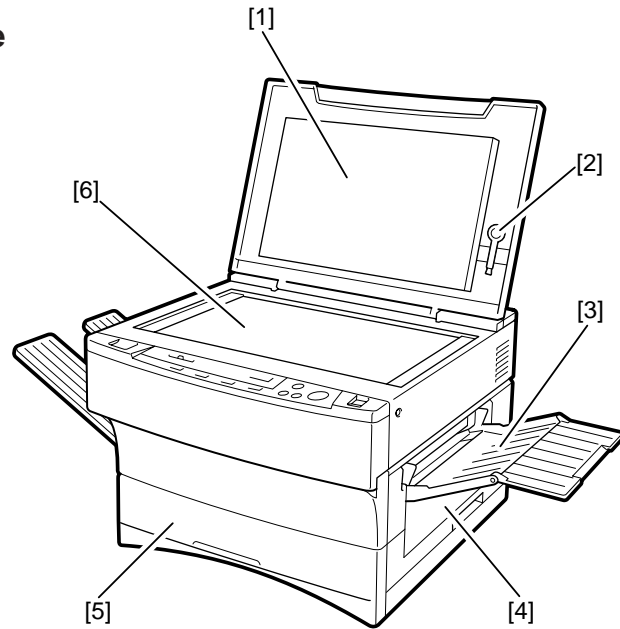

- |                               |                     |
|-------------------------------|---------------------|
| [1] Copyboard cover           | [4] Right door      |
| [2] Static eliminator cleaner | [5] Cassette        |
| [3] Manual feed tray          | [6] Copyboard glass |

Figure 1-301

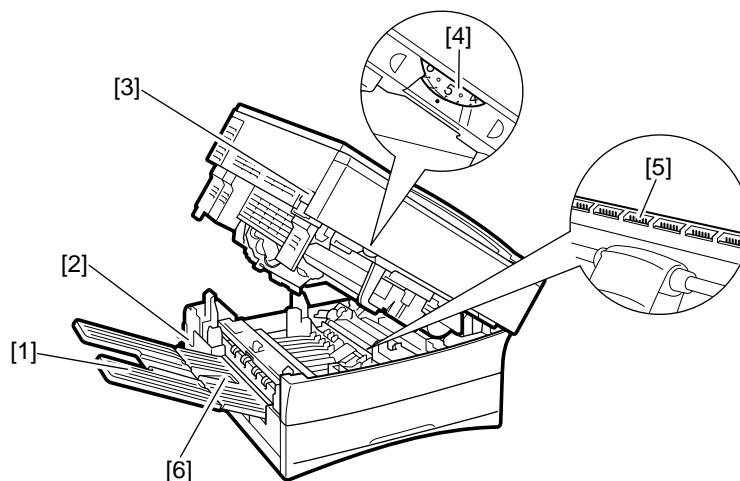

- |                          |                                  |
|--------------------------|----------------------------------|
| [1] Copy tray            | [4] Copy density correction dial |
| [2] Power cord connector | [5] Static eliminator            |
| [3] Open/close lever     | [6] Delivery guide plate         |

Figure 1-302

2. ADF Type

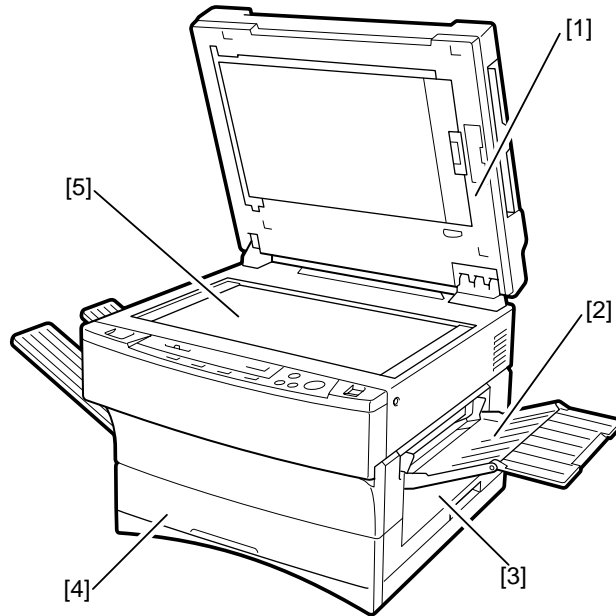

- |                      |                     |
|----------------------|---------------------|
| [1] ADF              | [4] Cassette        |
| [2] Manual feed tray | [5] Copyboard glass |
| [3] Right door       |                     |

Figure 1-303

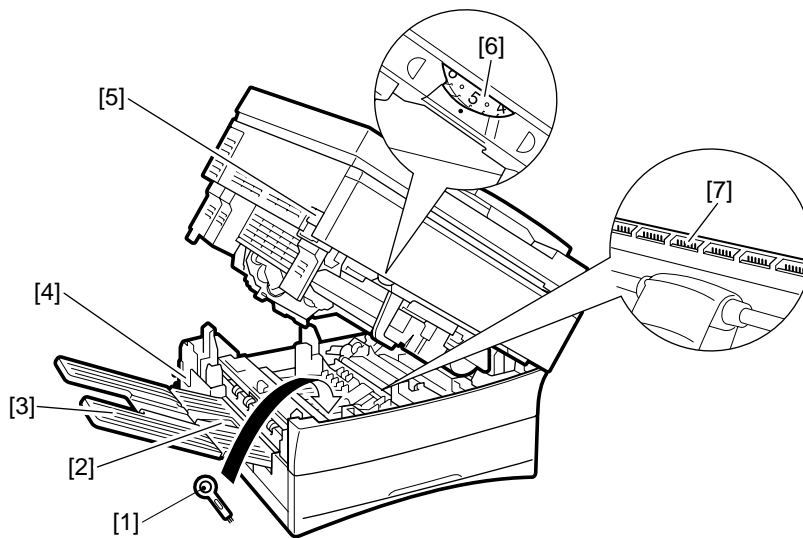

- |                               |                                  |
|-------------------------------|----------------------------------|
| [1] Static eliminator cleaner | [5] Open/close lever             |
| [2] Delivery guide plate      | [6] Copy density correction dial |
| [3] Copy tray                 | [7] Static eliminator            |
| [4] Power cord connector      |                                  |

Figure 1-304

3. ADF

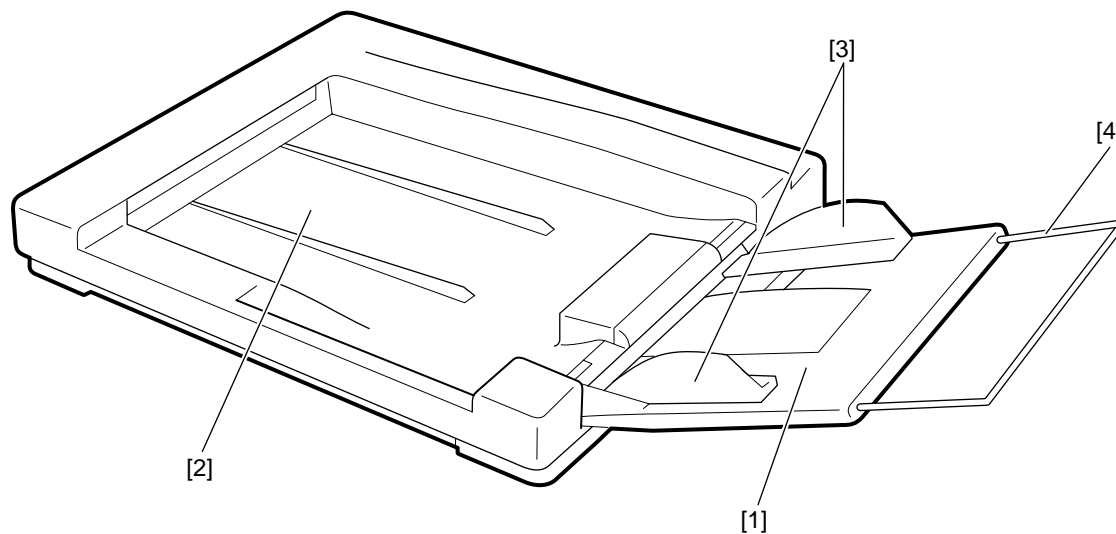

[1] Original tray  
[2] Original delivery tray

[3] Slide guide  
[4] Auxiliary tray

Figure 1-305

## B. Cross Section

### 1. Body

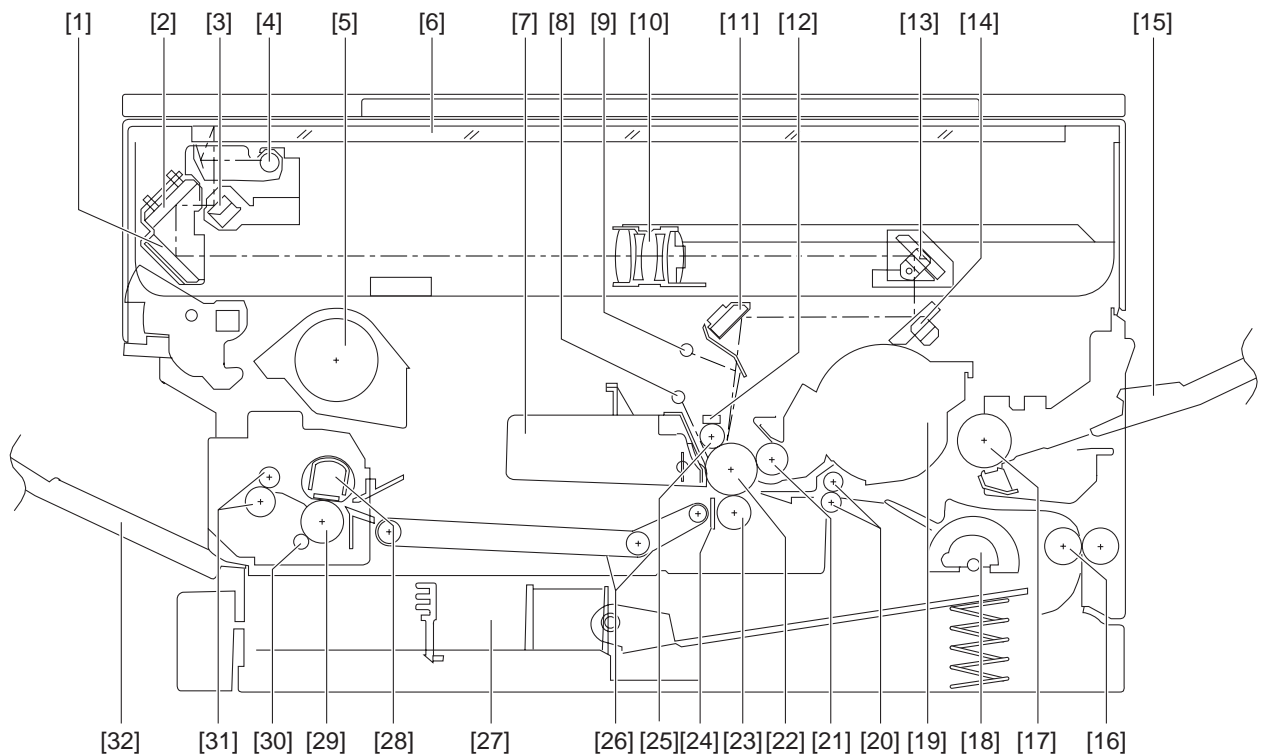

- |                        |  |                              |
|------------------------|--|------------------------------|
| [1] No. 3 mirror       | [12] Primary charging roller<br>cleaning pad | [22] Photosensitive drum     |
| [2] No. 2 mirror       | [13] No. 4 mirror                            | [23] Transfer roller         |
| [3] No. 1 mirror       | [14] No. 5 mirror                            | [24] Static eliminator       |
| [4] Scanning lamp      | [15] Multifeder tray                         | [25] Primary charging roller |
| [5] Heat exhaust fan   | [16] Vertical path roller                    | [26] Feed belt               |
| [6] Copyboard glass    | [17] Multifeder pickup roller                | [27] Cassette                |
| [7] Drum Unit          | [18] Cassette pickup roller                  | [28] Fixing upper unit       |
| [8] Pre-exposure lamp  | [19] Developing assembly                     | [29] Fixing lower roller     |
| [9] Side blanking lamp | [20] Registration roller                     | [30] Cleaning roller         |
| [10] Lens              | [21] Developing cylinder                     | [31] Delivery roller         |
| [11] No. 6 mirror      |  | [32] Copy tray               |

Figure 1-306

2. ADF

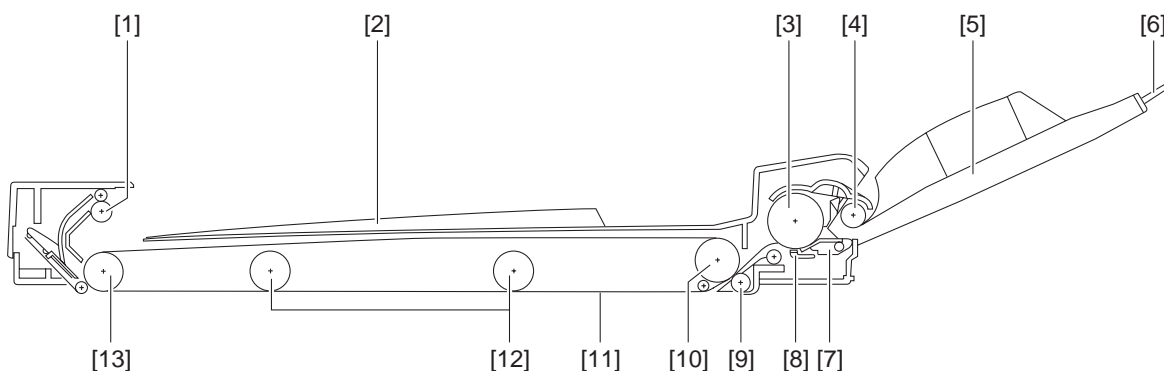

- |                     |                                  |
|---------------------|----------------------------------|
| [1] Delivery roller | [8] Separation pad               |
| [2] Copy tray       | [9] Registration roller          |
| [3] Pickup roller 2 | [10] Feed belt drive roller      |
| [4] Pickup roller 1 | [11] Feed belt                   |
| [5] Copyboard tray  | [12] Feed belt roller            |
| [6] Auxiliary tray  | [13] Feed belt link slave roller |
| [7] Guide plate     |                                  |

Figure 1-307



## IV. USING THE MACHINE

### A. Control Panel

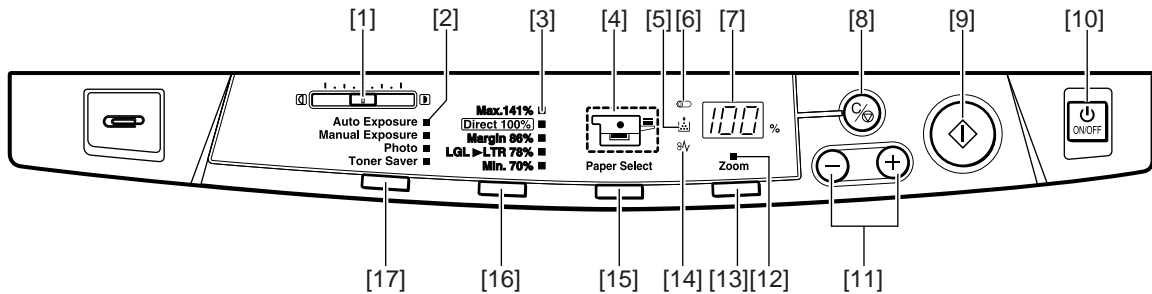

Figure 1-401

No.	Name	Description	Remarks
1	Copy density adjusting lever	Adjusts the density of copies manually.	
2	Copy density mode indicator	Indicates the selected copy density mode.	
3	Default ratio indicator	Indicates the selected default ratio.	
4	Paper selection indicator	Indicates the selected cassette/manual feed tray. If there is no paper loaded, it flashes.	
5	Replace toner cartridge indicator	Flashes when the toner cartridge must be replaced	
6	Replace drum unit indicator	Flashes to indicate that the drum unit must be replaced. If also flashes when it is necessary to have waste toner disposed of.	
7	Count/ratio indicator	<ul style="list-style-type: none"> <li>Indicates the number of copies or reproduction ratio.</li> <li>The symbol “%” turns on when indicating a ratio.</li> </ul>	100 (max.; continuous copying)
8	Clear/stop key	Stops copying or returns copying mode to standard mode.	Standard Mode Ratio: 100% Count: 1 Paper source: cassette Copy density: auto mode

No.	Name	Description	Remarks
9	Copy start key	Starts copying.	
10	Power switch	Turns on and off the power.	
11	Count/zoom set key	Sets the number of copies or a zoom ratio.	
12	Zoom indicator	Turns on when zoom mode is selected.	
13	Zoom key	Selects/deselects zoom mode.	May be between 70% and 141% in 1% increments.
14	Jam indicator	Flashes in response to a jam.	
15	Paper selection key	Selects the cassette/ manual feed tray.	
16	Default ratio key	Selects a default reproduction ratio.	
17	Copy density mode selection key	Selects copying density mode.	

**Table 1-401**

## B. User mode

Indication	Function	Description
U1	Primary charging roller cleaning	Use it to clean the primary charging roller. (See p. 4-31.)
U5*	DF recovery mode on/off	Use it to enable/disable recovery mode with the DF in use: 00: disable. 01: enable.
U6*	Feeder cleaning	Use it to clean the feeder. (See p. 1-16.)
U7	Installation/drum replacement mode	Use it at time of installation or replacement of the drum unit. (See p. 9-14.) • Indications '71': Enter 'PRIMARY'. '72': Enter 'IP_OFST'. '73': Enter the drum counter reading (in units of 1000 sheets). If no input is entered, '0' will be assumed. '74': Measures APVC and stirs toner.
U9	Reserved.	-----

\*Only if an ADF is installed.

**Table 1-402**

## V. ROUTINE MAINTENANCE BY THE USER

Instruct the user to clean the following if images tend to be soiled or copy paper tends to jam often.

### 1. Soiled Images

#### a. Copyboard Glass/Copyboard Cover

Clean the cover with a moist cloth (with water or mild detergent solution); then, dry wipe it.

#### b. Feeding Belt (ADF type)

##### b.1 Cleaning in Feeder Cleaning Mode

- 1) Turn on the machine, and hold down the Copy Density Mode Selection key for 4 sec or more.
  - The count/ratio indicator will indicate 'U6'.

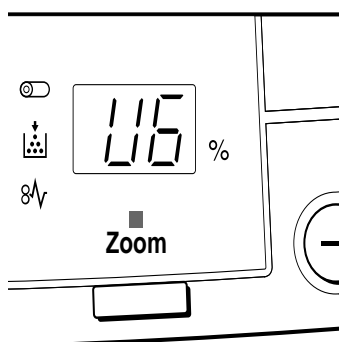

Figure 1-501

- 2) Place about 10 sheets of blank copy paper (A4/LTR) on the original tray of the ADF.
- 3) Press the Copy Start key.
  - Copy paper will be fed from the original tray.
  - The indicator flashes 'U6' while the feeder is being cleaned.
- 4) Press the Copy Density Mode Selection key to end the mode.

#### Caution:

- You cannot start feeder cleaning mode while the machine is making copies or if an error exists.
- The auto power-off mechanism does not operate while feeder cleaning mode is being executed.

## b.2 Cleaning by Hand

- 1) Wipe the feed belt with a moist cloth (water or mild detergent solution) in the direction of the arrow in the figure; then, dry wipe it.

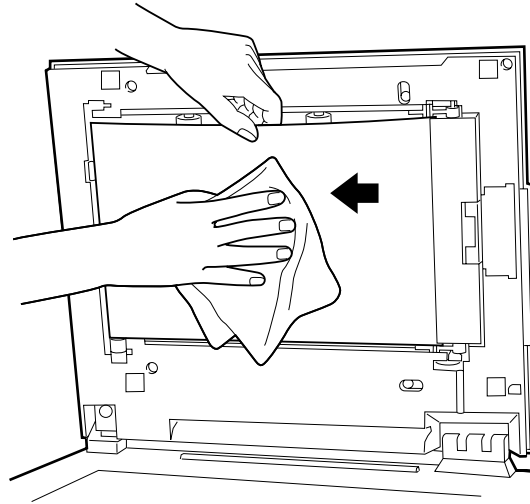

Figure 1-502

## 2. If Jams Occur Frequently

### a. Static Eliminator

- 1) Remove the static eliminator cleaner from the machine.

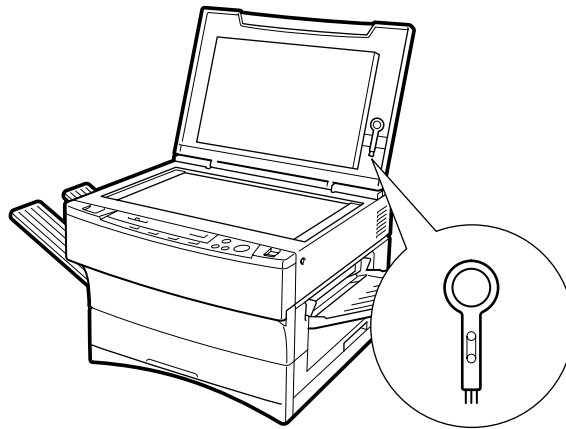
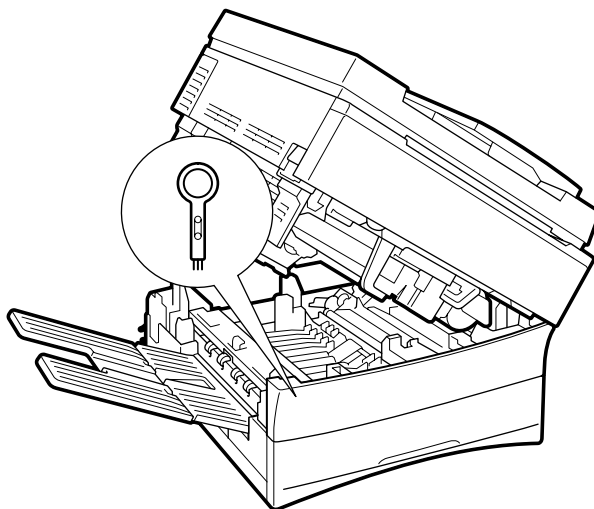
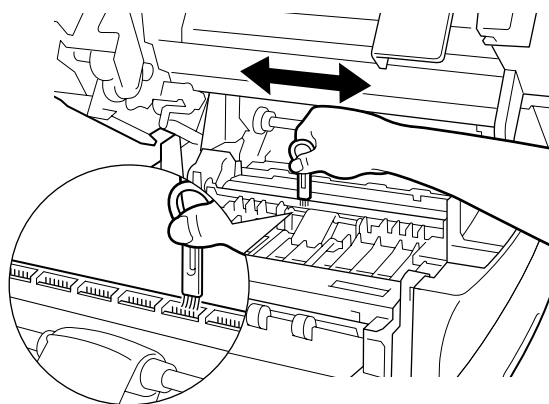

Figure 1-503 (Copyboard type)



**Figure 1-504 (ADF type)**

- 2) Pull the open/close lever to open the machine.
- 3) Using the static eliminator cleaner, clean the static eliminator.
  - Brush out the paper lint or the like from the groove of the static eliminator.



**Figure 1-505**

- 4) Close the machine as soon as you have finished cleaning. (Work briskly.)

## VI. IMAGE FORMATION

### A. Outline

The construction of the machine is as follows:

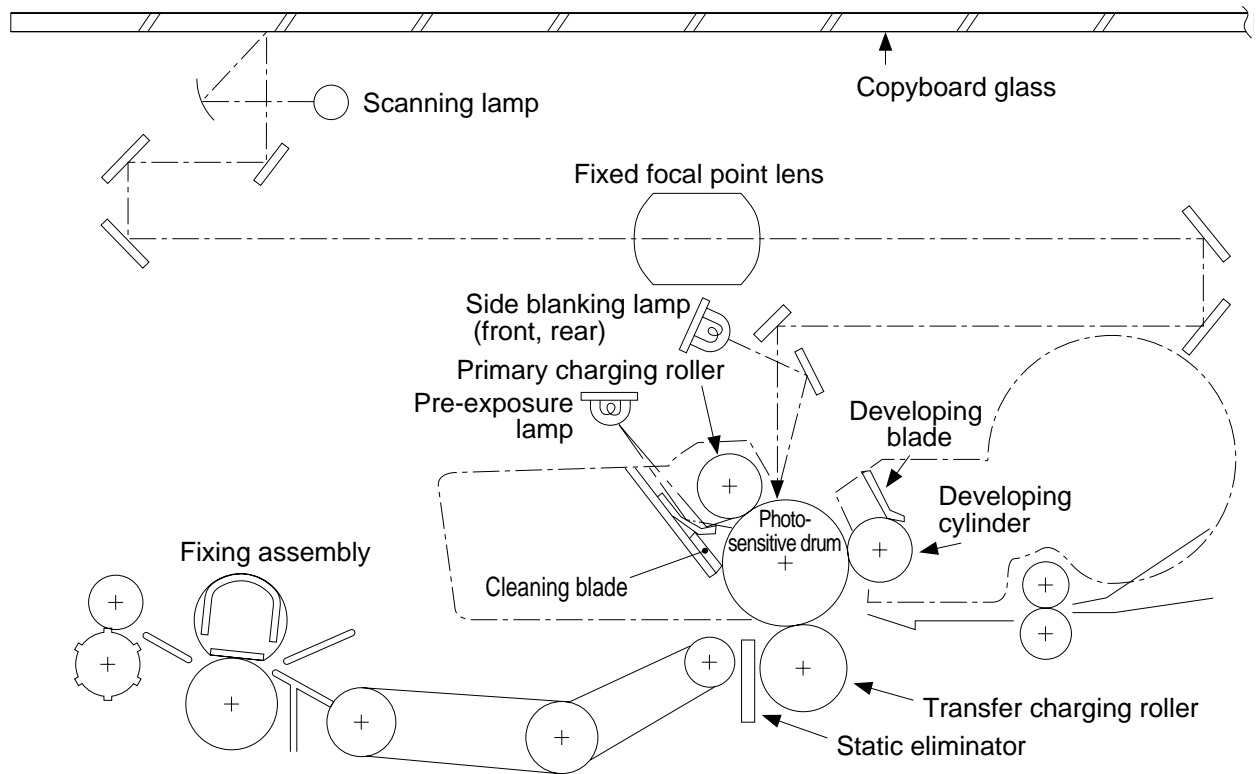

Figure 1-601

The machine's image formation process consists of the following seven steps:

- Step 1 Pre-exposure
- Step 2 Primary charging (negative DC)
- Step 3 Image exposure
- Step 4 Development (AC + negative DC)
- Step 5 Transfer (negative DC)
- Step 6 Separation (curvature separation + static eliminator; positive DC)
- Step 7 Fixing
- Step 8 Drum cleaning

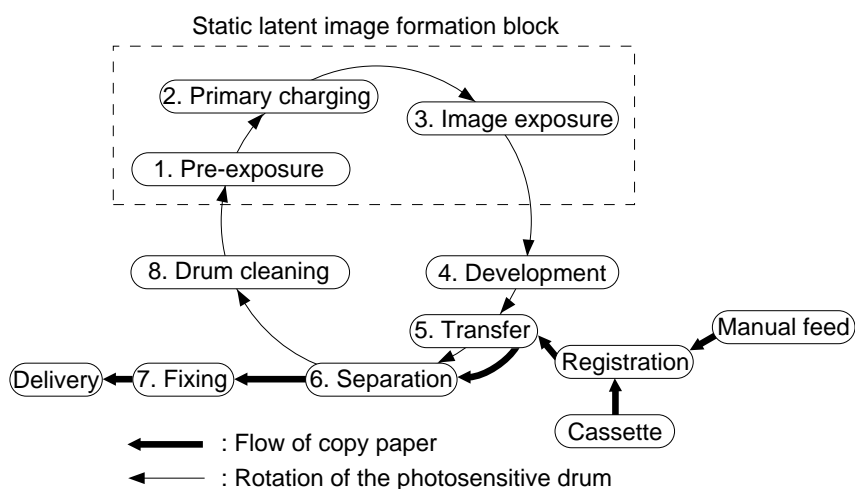

Figure 1-602



---

# CHAPTER 2

---

## BASIC OPERATION

---

This chapter provides descriptions on basic operations, functions of each operation, relationships between electrical and mechanical systems, and timing at which each associated part is turned on.

Process speed	96 mm/sec
---------------	-----------

I. BASIC OPERATIONS .....	2-1	D. Controlling the Main	
A. Functional Construction .....	2-1	Motor (M1) .....	2-5
B. Outline of Electrical		E. Inputs to and Outputs from the	
Circuitry .....	2-2	DC Controller .....	2-7
C. Basic Sequence of			
Operations .....	2-3		



# I. BASIC OPERATIONS

## A. Functional Construction

The machine consists of four functional blocks: pickup/feeding system, exposure system, image formation system, and control system.

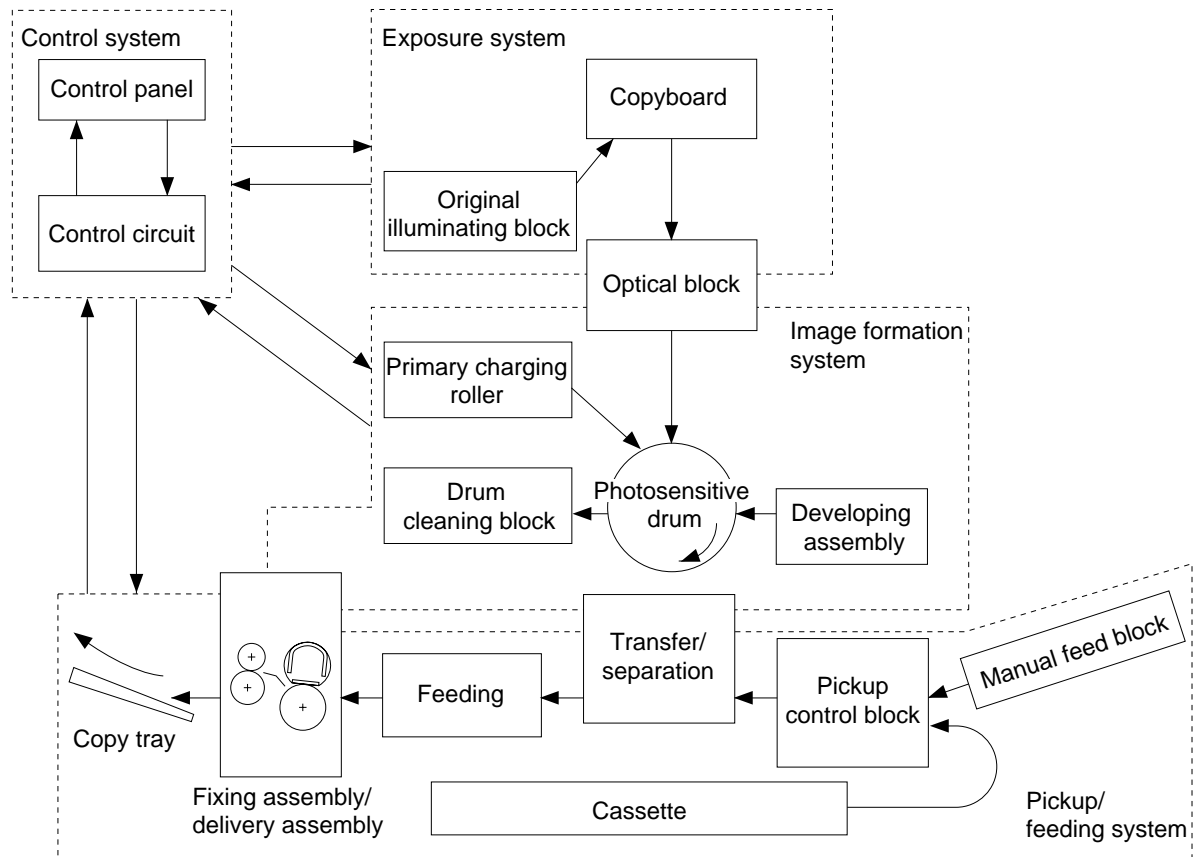

Figure 2-101

## B. Outline of Electrical Circuitry

The machine's major electric mechanisms are controlled by the microprocessor mounted on the DC controller PCB, which reads input signals from sensors and operating keys according to the instructions of the program stored in advance and sends signals used to drive motors, solenoids, lamps, and other loads as needed.

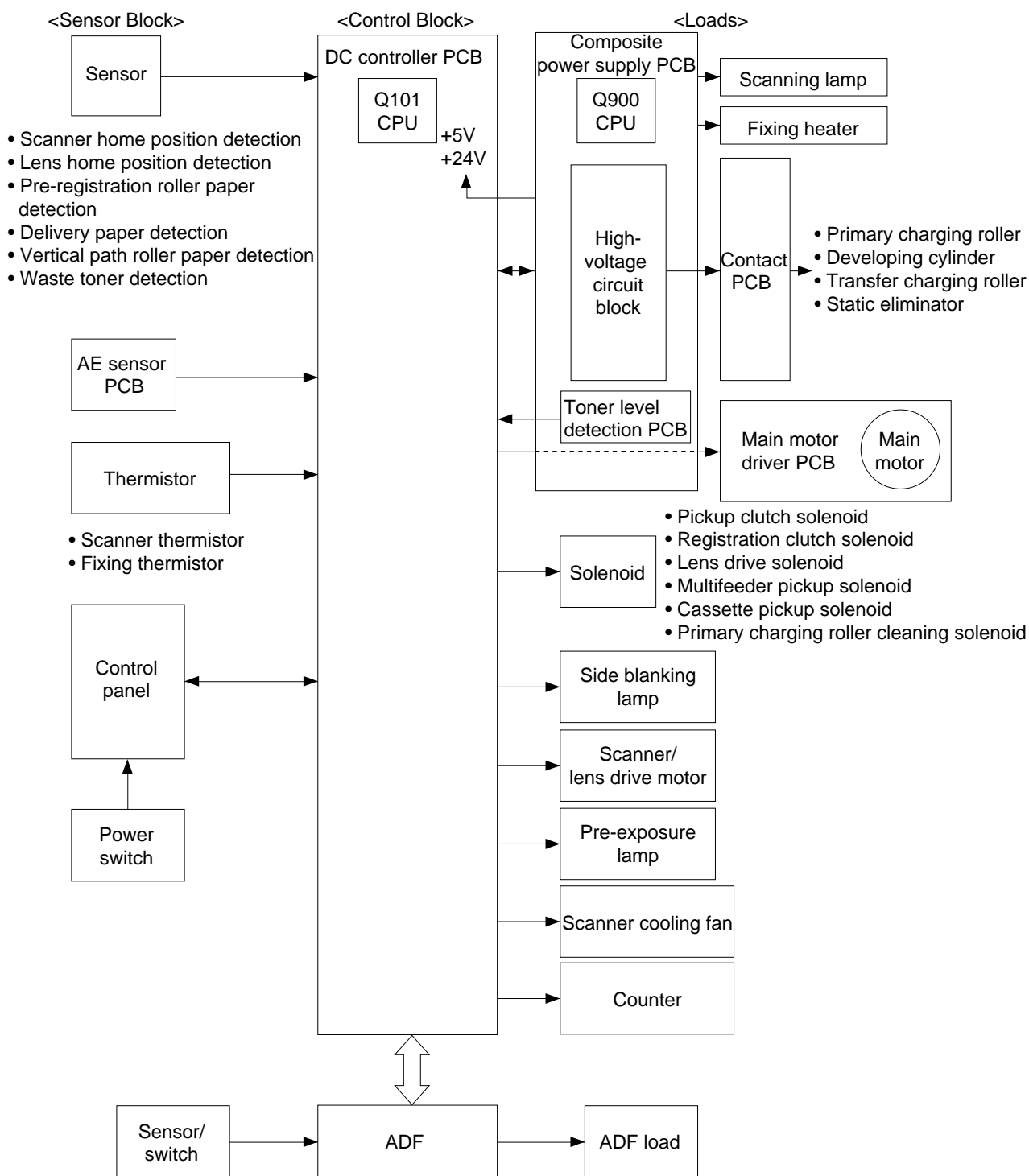
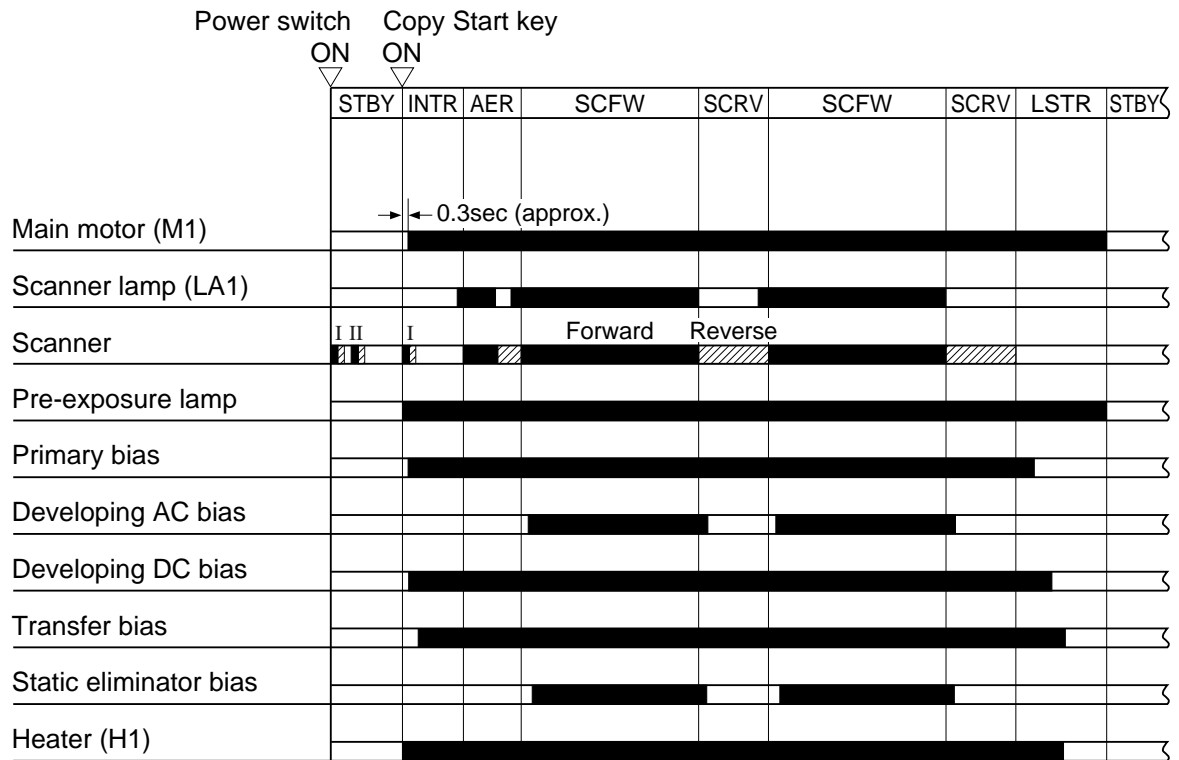

Figure 2-102

### C. Basic Sequence of Operations

- A4R, Direct, 2 Copies, Continuous, Cassette



- I: Scanner home position detection
- II: Lens home position detection

Figure 2-103

	Period	Description
STBY (standby)	<ul style="list-style-type: none"> <li>• From when the power switch is turned on to when the Copy Start key is pressed.</li> <li>• From when LSTR ends to when the Copy Start key is pressed.</li> </ul>	Waits until the Copy Start key is pressed.
INTR (initial rotation)	From when the Copy Start key is pressed to when the scanner moves forward.	Removes residual charges from the photosensitive drum, thereby ensuring a stable drum sensitivity.
AER (AE rotation)	While the scanner moves forward about 10 cm and then moves it in reverse.	Measures the density of the original.
SCFW (scanner forward)	While the scanner is moving forward. <ul style="list-style-type: none"> <li>• The distance varies according to the selected copy size and reproduction ratio.</li> <li>• The forward speed varies according to the selected reproduction ratio.</li> </ul>	Illuminates the original by the scanning lamp, and the reflected optical image is projected to the photosensitive drum through mirrors and lenses.
SCRV (scanner reverse)	While the scanner is moving in reverse. <ul style="list-style-type: none"> <li>• The reverse speed is about 3.3 as fast as the forward speed used in Direct.</li> </ul>	Moves the scanner to the home position in preparation for the next copying run.
LSTR (last rotation)	From when SCRv ends to when the main motor stops.	Neutralizes the drum surface potential as post-processing.

Table 2-101

## D. Controlling the Main Motor (M1)

### 1. Outline

Table 2-102 shows the functions of the main motor control circuit, and Figure 2-104 is a block diagram of the circuit.

Item	Description
Power supply	24 VDC from the composite power supply.
Drive signal	Signal (MMD) from the DC controller PCB.
Moving/drive parts	Photosensitive drum, primary charging roller, developing assembly, transfer charging roller, pickup roller, vertical path roller, registration roller, feeding assembly, fixing assembly, delivery roller, heat exhaust fan
Control	Executes on/off control. Executes constant speed rotation control.
Error detection	Issues 'E010'.

Table 2-102

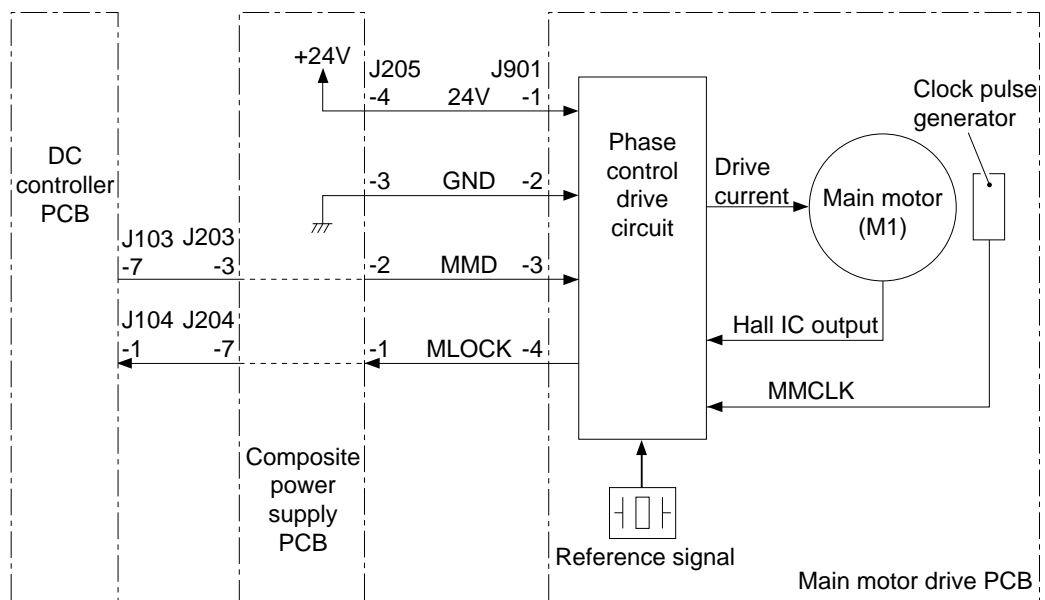

Figure 2-104

## 2. Operations

The main motor (M1) is a DC motor with a built-in clock pulse generator, which generates clock pulses (MMCLK) in relation to the rotation of the motor while the motor is rotating.

The speed control circuit controls the main motor (M1) so that it rotates at a specific speed by matching the frequency of these clock pulses and that of the reference signals.

When the main motor drive signal (MMD) from the DC controller circuit goes '1', the motor driver drive circuit turns on, causing the main motor (M1) to rotate at a specific speed.

While the main motor is rotating at a specific speed, the main motor driver PCB keeps sending the constant speed state signal (MLOCK=0) to the DC controller PCB. If the rotation of the motor starts to have fluctuations, the MLOCK signal goes '1'.

### Related Error Code

E010

While the main motor drive signal is generated, the rotation of the main motor deviates from a specific number for 1 sec or more.

#### a. Turning On/Off the Main Motor

When the main motor drive signal (MMD) from the DC controller circuit goes '1', the main motor driver turns on to rotate the main motor (M1).

#### b. Rotating the Main Motor at a Constant Speed

The drive circuit on the motor driver PCB controls the main motor so that the phase of the frequency of the clock pulse signals (MMCLK) occurring when the motor rotates and that of the frequency of the reference signals match. The main motor driver PCB sends the constant speed state signal (MLOCK=0) to the DC controller circuit.

#### c. Detecting an Error (E010)

If the rotation of the main motor starts to have fluctuations for some reason, the MLOCK signal goes '1'. If the signal remains '1' for about 1 sec, the DC controller will find the condition to be a fault in the main motor, and will stop the main motor and, at the same time, indicate 'E010' in the display.



## E. Inputs to and Outputs from the DC Controller

### 1. Inputs to the DC Control (1/2)

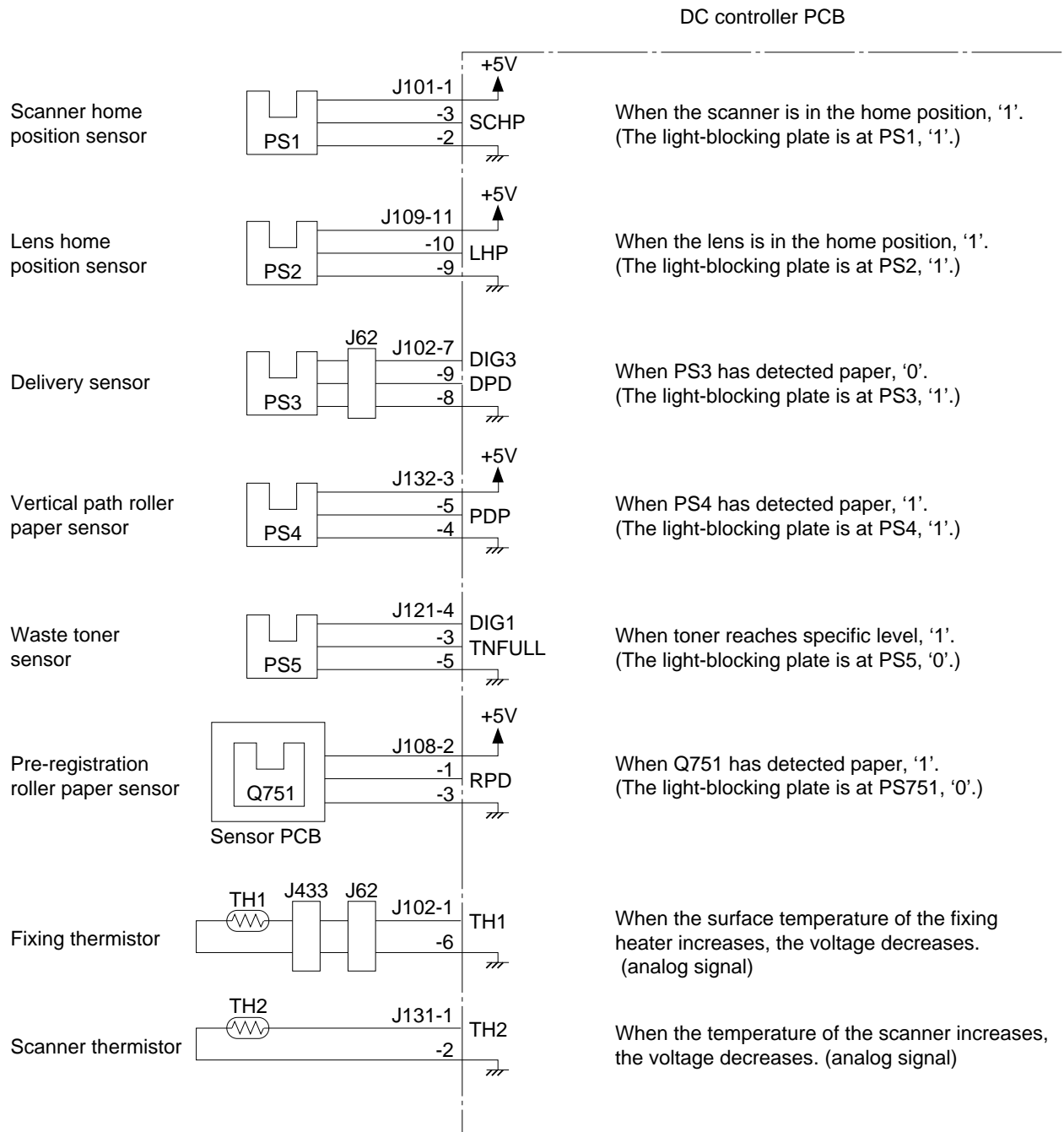

Figure 2-105

2. Inputs to the DC Controller (2/2)

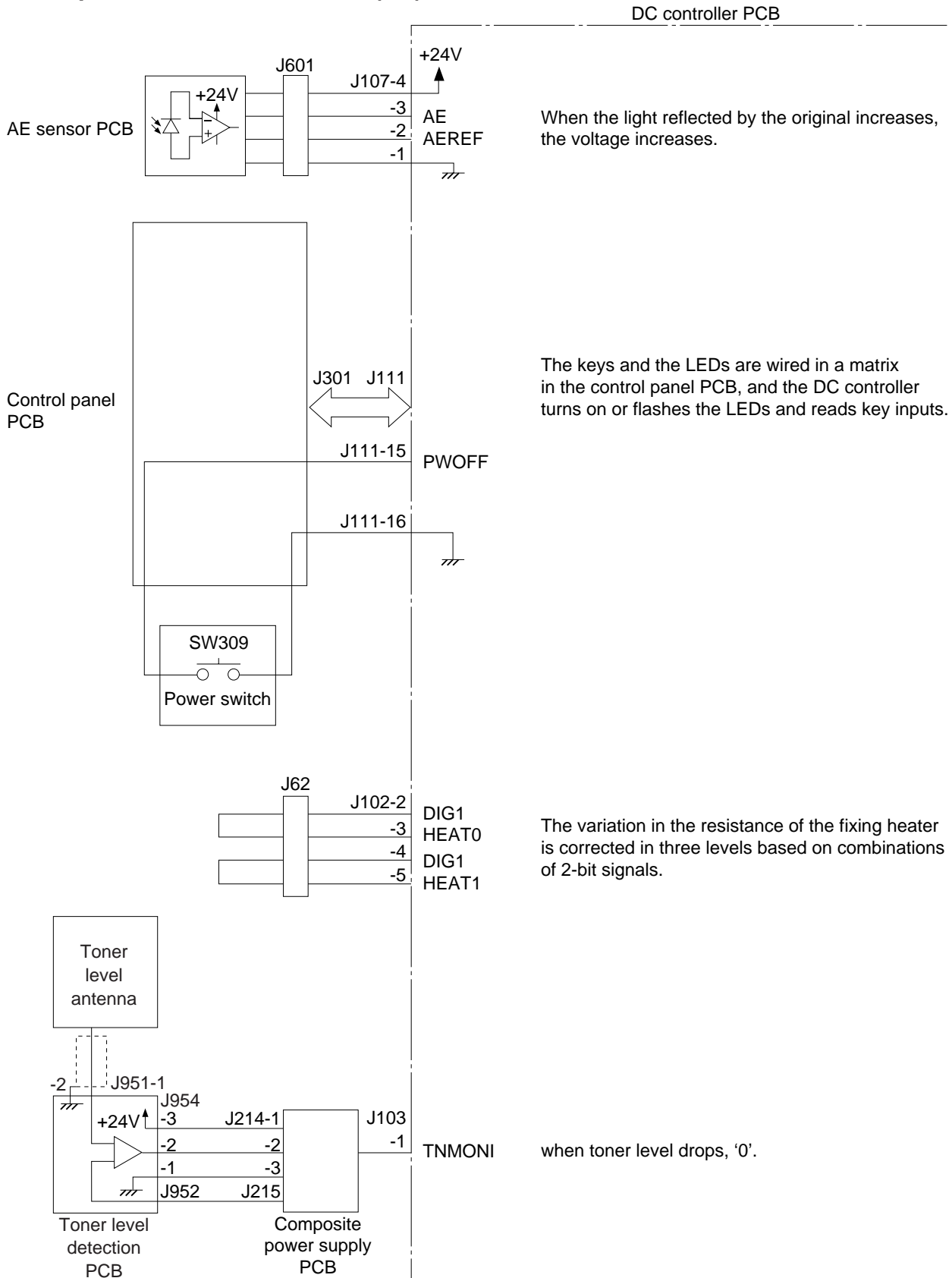

Figure 2-106

3. Outputs from the DC Controller (1/2)

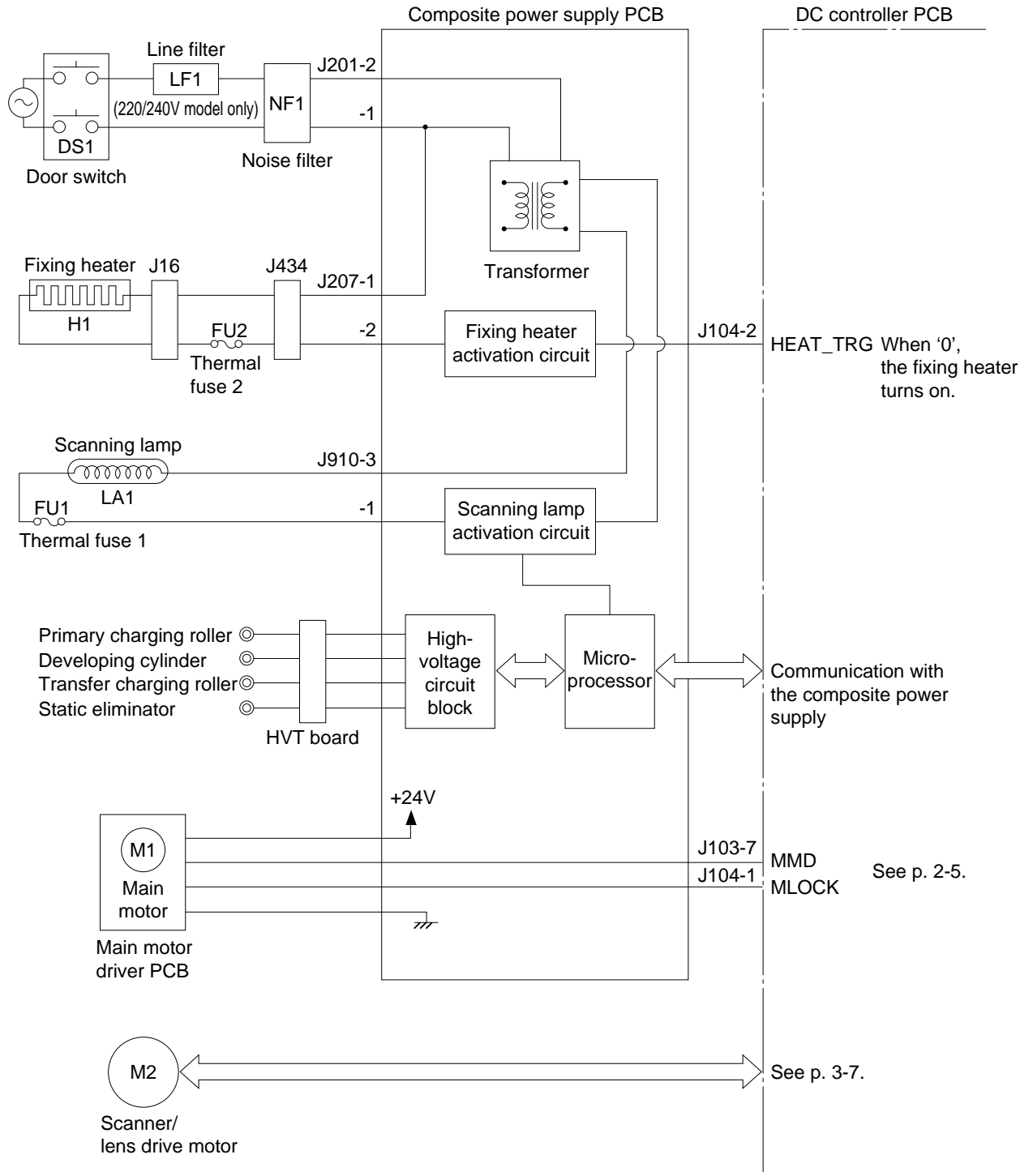

Figure 2-107

4. Outputs from the DC Control PCB (2/2)

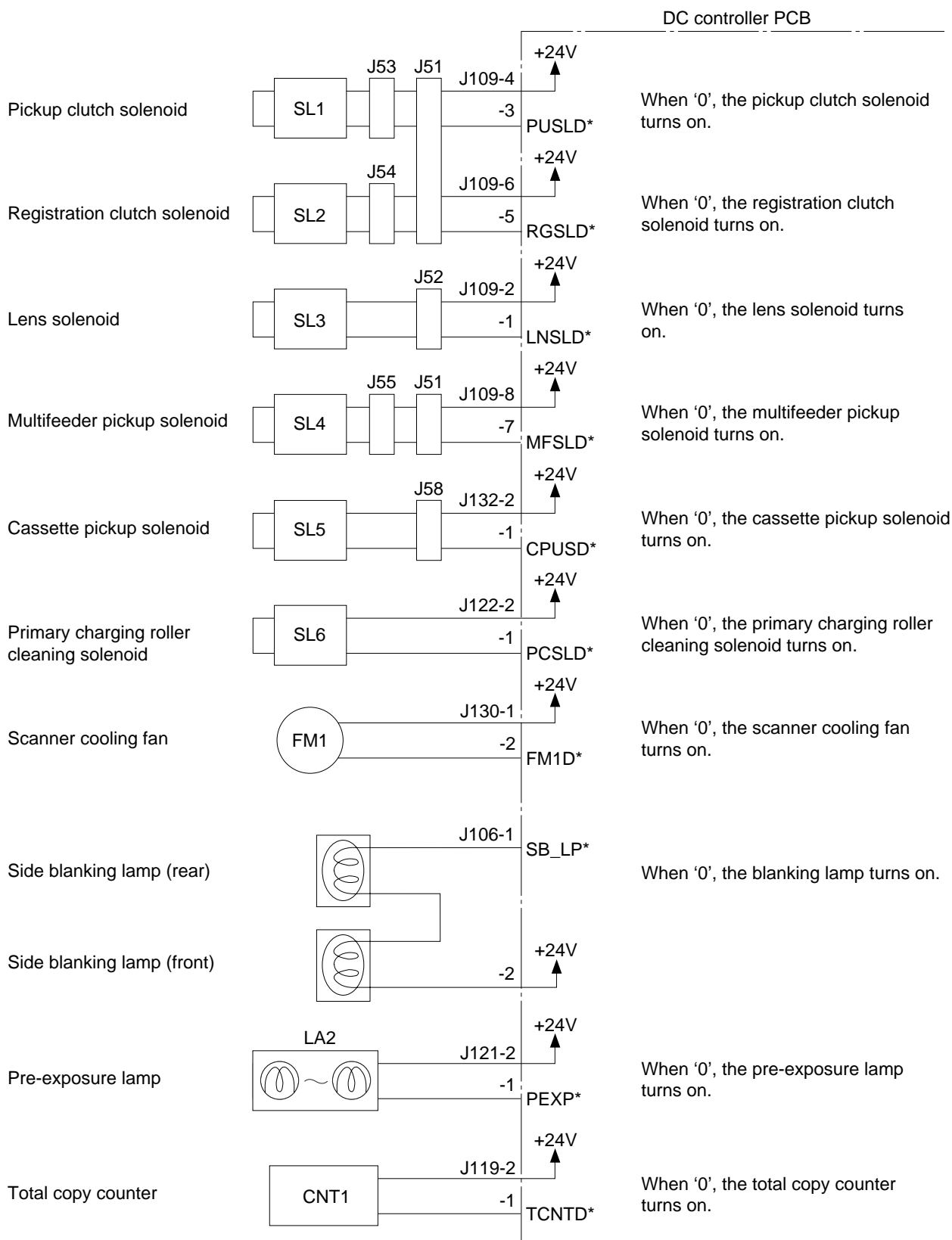

Figure 2-108

5. Inputs to and Outputs from the ADF

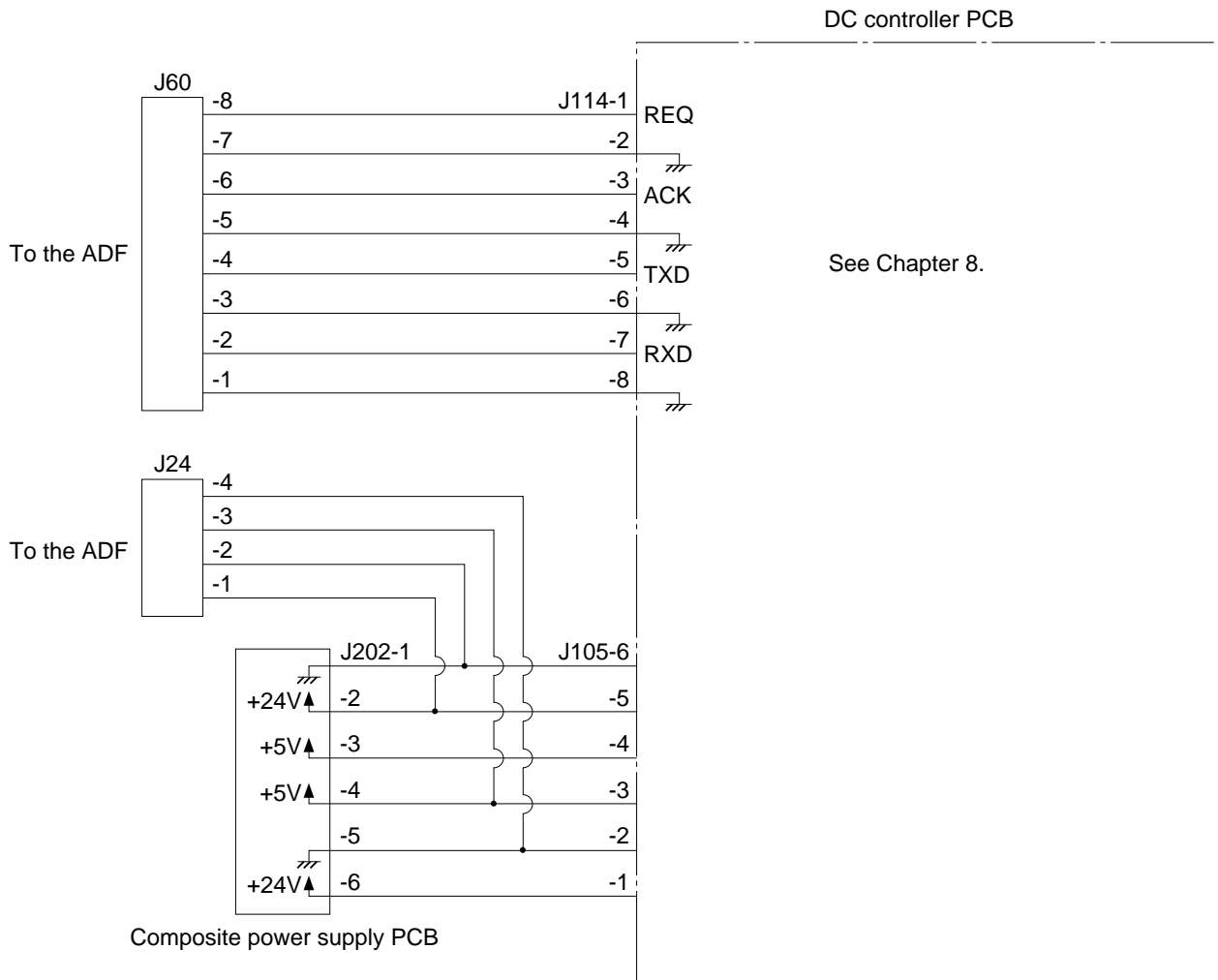

Figure 2-109



---

# CHAPTER 3

---

## EXPOSURE SYSTEM

---

This chapter discusses the principles of operation used for the machine's lens drive unit and scanner drive unit. It also explains the timing at which these drive units are operated, and shows how they may be disassembled/assembled and adjusted.

I. OPERATIONS .....	3-1	III. DISASSEMBLY/ASSEMBLY .....	3-13
A. Outline .....	3-1	A. Scanner Drive Assembly ....	3-14
B. Varying the Reproduction Ratio .....	3-2	B. Lens Drive Assembly .....	3-32
C. Lens Drive System .....	3-3	C. Exposure System .....	3-38
D. Scanner Drive System .....	3-4		
II. EXPOSURE SYSTEM .....	3-9		
A. Controlling the Scanning Lamp .....	3-9		





# I. OPERATIONS

## A. Outline

Table 3-101 shows the major functions of the exposure system.

Item	Description
Lamp	Halogen
Scanning	By moving the No. 1 mirror mount
Scanner position detection	By a sensor (scanner home position sensor; PS1)
Ratio variation	Main scanning direction:by varying the optical length Sub scanning direction:by varying the speed of the No. 1 mirror mount
Lens drive control	Scanner/lens drive motor (M2) Fixed focal point lens unit Mobile No. 4/5 mirror unit
Scanner drive control	Scanner/lens drive motor (M2) Scanner thermistor (TH2)
Protective function	By a fuse (blows in response to overheating of the scanning lamp to cut power to the lamp) • Thermal fuse (FU1; blows at 128°C)

**Table 3-101**

Copyboard glass

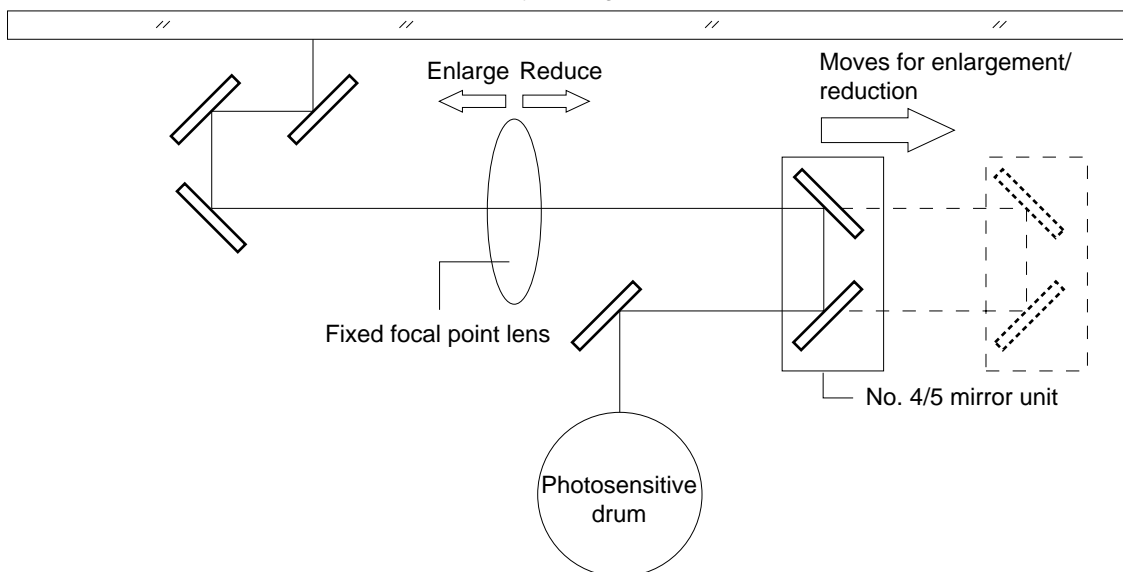

**Figure 3-101**

## B. Varying the Reproduction Ratio

The reproduction ratio in the drum axial direction (main scanning direction) is varied by the lens drive system, and that in the drum peripheral direction (sub scanning direction) is changed by the scanner drive system.

In the lens drive system, the positions of the fixed focal point lens and the No. 4/5 mirror are changed to vary the reproduction ratio.

In the scanner system, the relative speed of the No. 1 mirror mount is made higher (for reduction) or lower (for enlargement) than the drum peripheral speed.

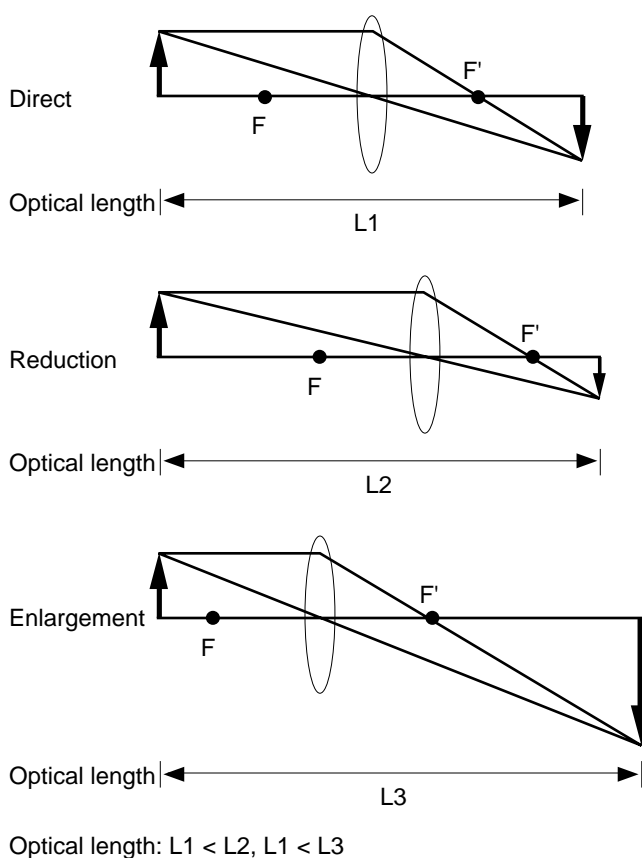

Figure 3-102

## C. Lens Drive System

### 1. Outline

The lens drive system is driven by the scanner/lens drive motor (M2). When the lens solenoid (SL3) turns on, the switching gear is pushed in the direction of  $\rightarrow$ . In this condition, when the scanner/lens drive motor rotates in reverse direction ( $\curvearrowright$ ), the lens unit will move in the direction of reduction ( $\rightarrow$ ) by the work of the gear and the lens cable.

At the same time, the No. 4/5 mirror unit operates according to the distance over which the lens unit is moved by the work of the gear and the cam, thereby varying the optical length.

At this time, the blanking lamp also moves in conjunction with the lens to blank out the appropriate front/rear widths to suit the selected reduction ratio.

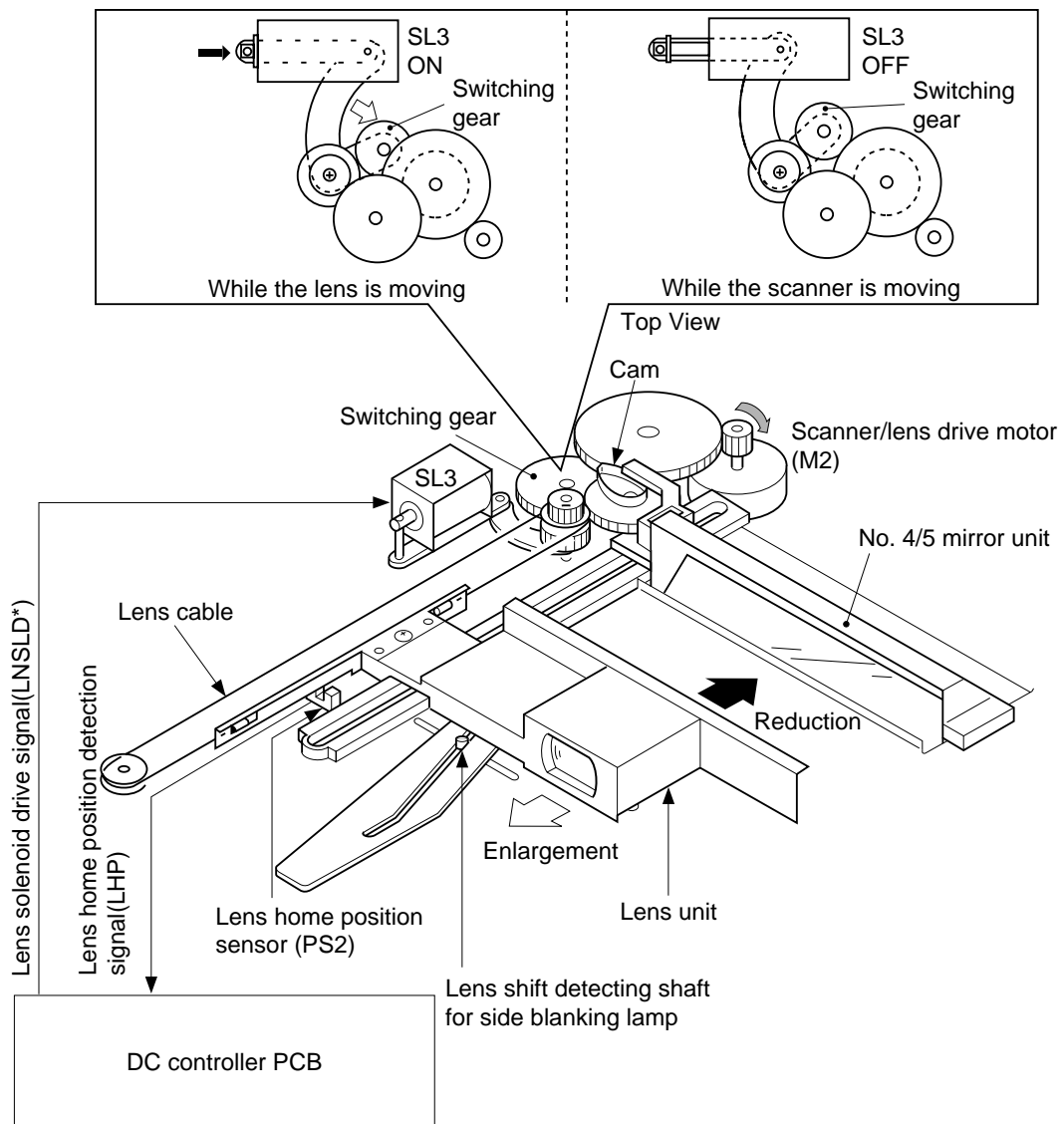

Figure 3-103

## D. Scanner Drive System

### 1. Outline

The scanner is driven by the scanner/lens drive motor (M2), whose direction of rotation changes to move the scanner forward or in reverse.

When moving the scanner forward, the speed of rotation of the motor varies according to the selected reproduction ratio on a continuous basis; when moving the scanner in reverse, on the other hand, its speed remains the same regardless of the selected reproduction ratio in normal copying (312mm/sec, about 3.3 as fast as when moving the scanner forward in Direct).

The distance over which the scanner is moved varies according to the length of copy paper and the selected reproduction ratio.

The scanner/lens drive motor drives the lens drive system as well as the scanner.

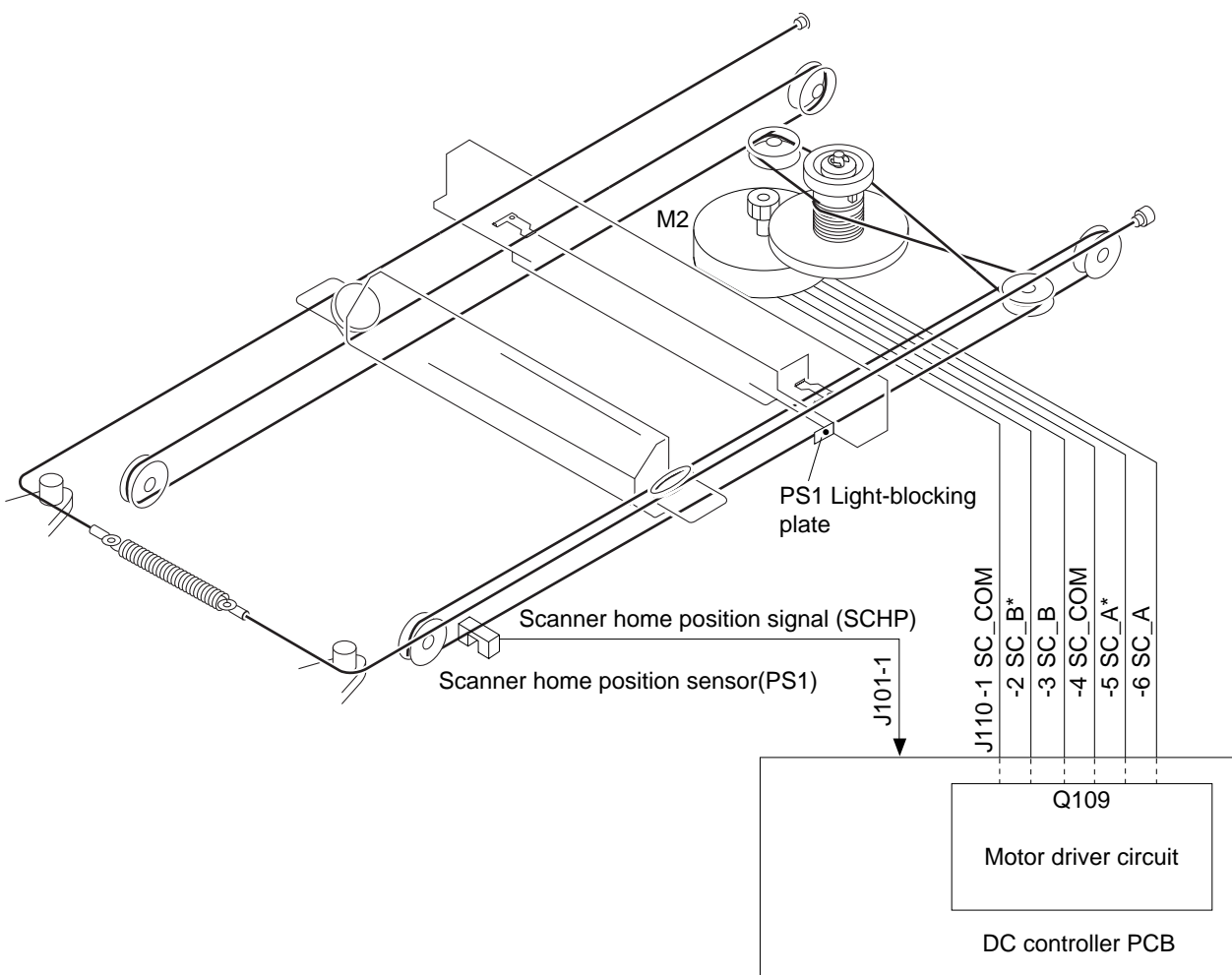

Figure 3-104

2. Relationship between Scanner Sensor and Signal

Scanner sensor	Signal	Scanner		Description
		Forward	Reverse	
PS1(scanner home position sensor)	SCHP			<ul style="list-style-type: none"> <li>Provides a means of reference for determining forward movement distance.</li> <li>Stops the scanner moving in reverse in 0.1 sec.</li> </ul>
				

Table 3-102

3. Basic Sequence of Operations (scanner)

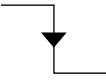
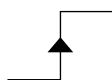
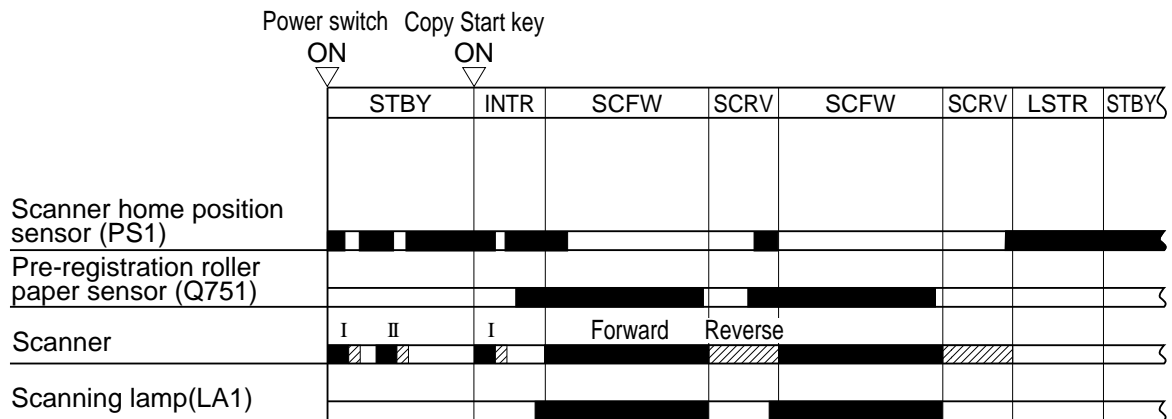

- I: Scanner home position detection
- II: Lens home position detection

Figure 3-105

The microprocessor on the DC controller PCB controls the forward movement distance of the scanner with reference to the falling edge of the scanner home position signal. The forward movement distance of the scanner varies according to the length of copy paper and reproduction ratio. If the ratio is less than 130%, the scanner is moved forward as if for A4 (297 mm); if it is 130% or more, the scanner is moved forward as if for LTR (279 mm).

\*For descriptions on how length is detected, see p. 5-7.

#### 4. Controlling the Copying Speed

The machine uses a halogen lamp for scanning, and the heat of the lamp increases the temperature of the copyboard.

To prevent possible overheating of the copyboard glass, the temperature of the scanner is monitored by a thermistor (TH2); if its reading reaches 37.5°C or higher, the copying speed is reduced to 6 cpm.

If this mechanism turns on during continuous copying, it remains on until the end of the copying job.

At the end of copying, if the reading of the thermistor is 34.5°C or higher, the No. 1 mirror mount is moved forward 105 mm from the home position and stopped, thereby lowering the temperature of the copyboard fast.

Reference:

While the copying speed is controlled to 6 cpm, the speed of the reverse movement of the scanner is reduced to prevent overheating of the copyboard glass. (about 75 mm/sec)

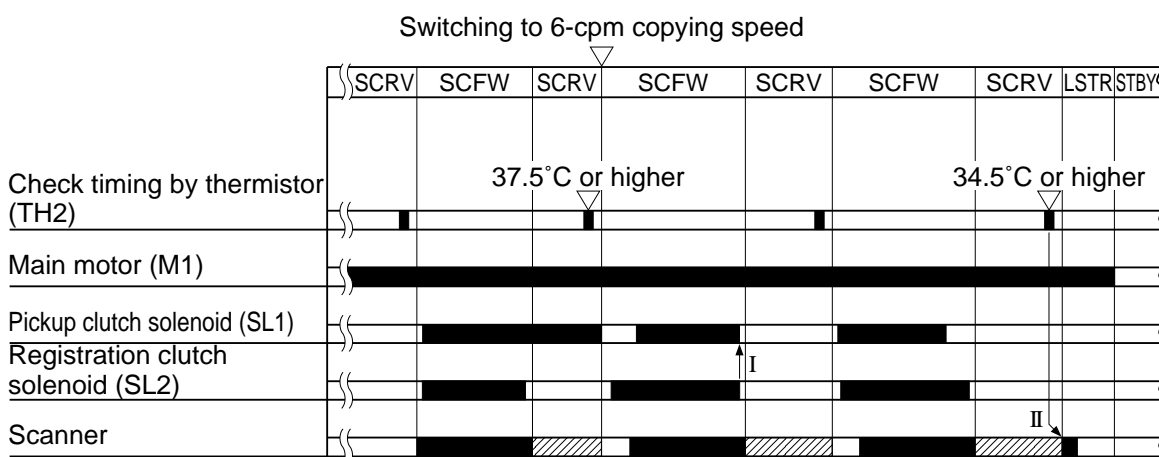

- I: When the registration clutch solenoid (SL2) is off, the pickup clutch solenoid is turned off to prevent overheating of the pickup clutch solenoid (SL1).
- II: By the time the Copy Start key is pressed or the power switch is turned off and then on again next time, the scanner is moved to and stopped at 105 mm forward from the home position.

Figure 3-106

5. Controlling the Scanner/Lens Drive Motor

a. Outline

The scanner/lens drive motor (M2) is a 4-phase stepping motor. The timing at which the drive power (SC-COM) and pulses (SC-A, SCA\*, SC-B, SC-B\*) are generated is controlled to turn on/off the scanner/lens drive motor (M2) or to switch the direction of its rotation.

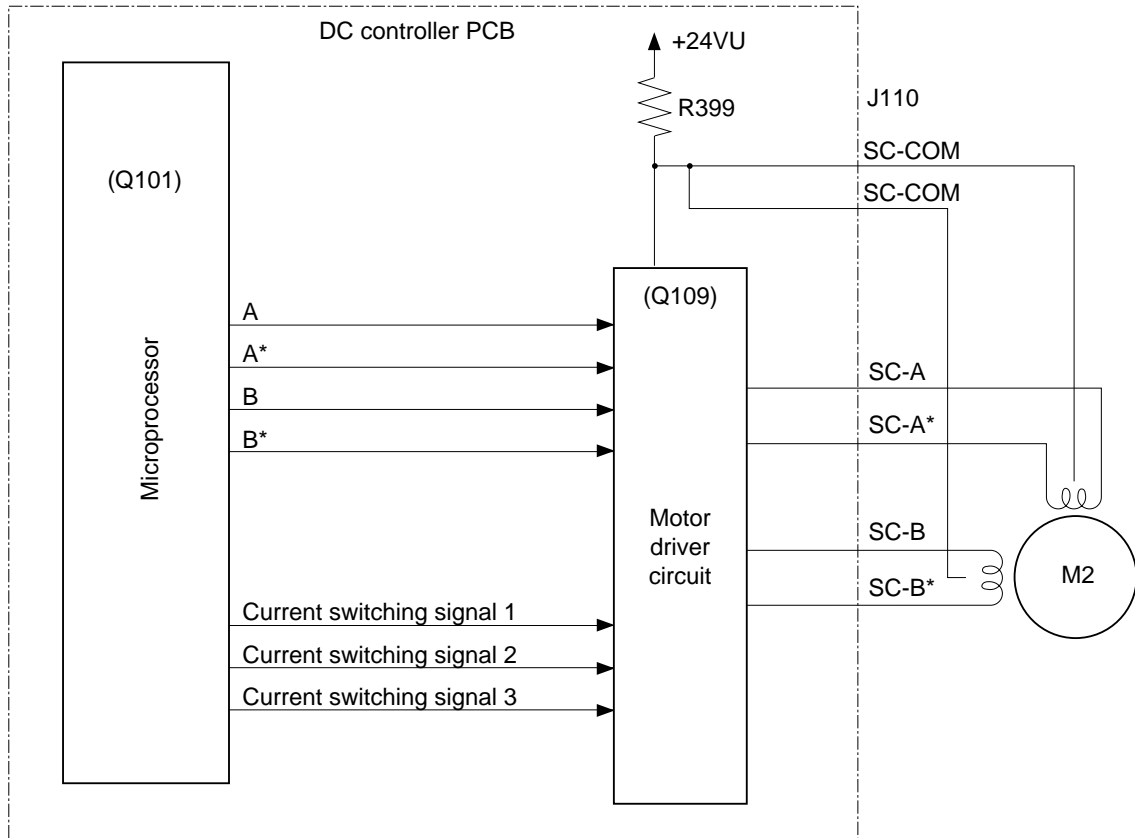

Figure 3-107

b. Operations

The microprocessor (Q101) mounted on the DC controller PCB receives instructions from the control panel PCB copying mode settings (e.g., reproduction ratio). In response, it applies drive pulses to the scanner/lens drive motor (M2) through the motor driver circuit.

The scanner motor is a 4-phase stepping motor, and changes the direction and speed of its rotation according to the sequence and frequency of drive pulses (SC-A\*through SC-B\*).

The motor drive voltage is switched on and off by pulse signals (A through B\*) generated by the microprocessor (Q101). Any of these pulse signals is generated when the motor is in operation, while no pulse signal is generated when the motor is at rest.

The current switching signals from 1 to 3 generated by the microprocessor (Q101) are used to control the current flowing to the motor so that it varies according to the state of the scanner and the lens.

	Starting the lens	Moving the lens	Reversing the scanner	Forwarding the scanner
Current switching signal 1	0	0	0	1
Current switching signal 2	0	0	1	1
Current switching signal 3	0	1	1	1

c. Detecting Overcurrent for the Scanner/Lens Drive Motor

If overcurrent flows to the scanner/lens drive motor for some reason, the fuse (R339) on the DC controller PCB will blow to cut the power to the motor.

**Caution:**

The fuse (R339) will not recover once it has blown.



## II. EXPOSURE SYSTEM

### A. Controlling the Scanning Lamp

#### 1. Outline

Figure 3-201 shows the circuit used to control the scanning lamp, and has the following functions:

- Turning on/off the scanning lamp.
- Controlling the intensity of the scanning lamp.
- Monitoring the state (on/off) of the scanning lamp.

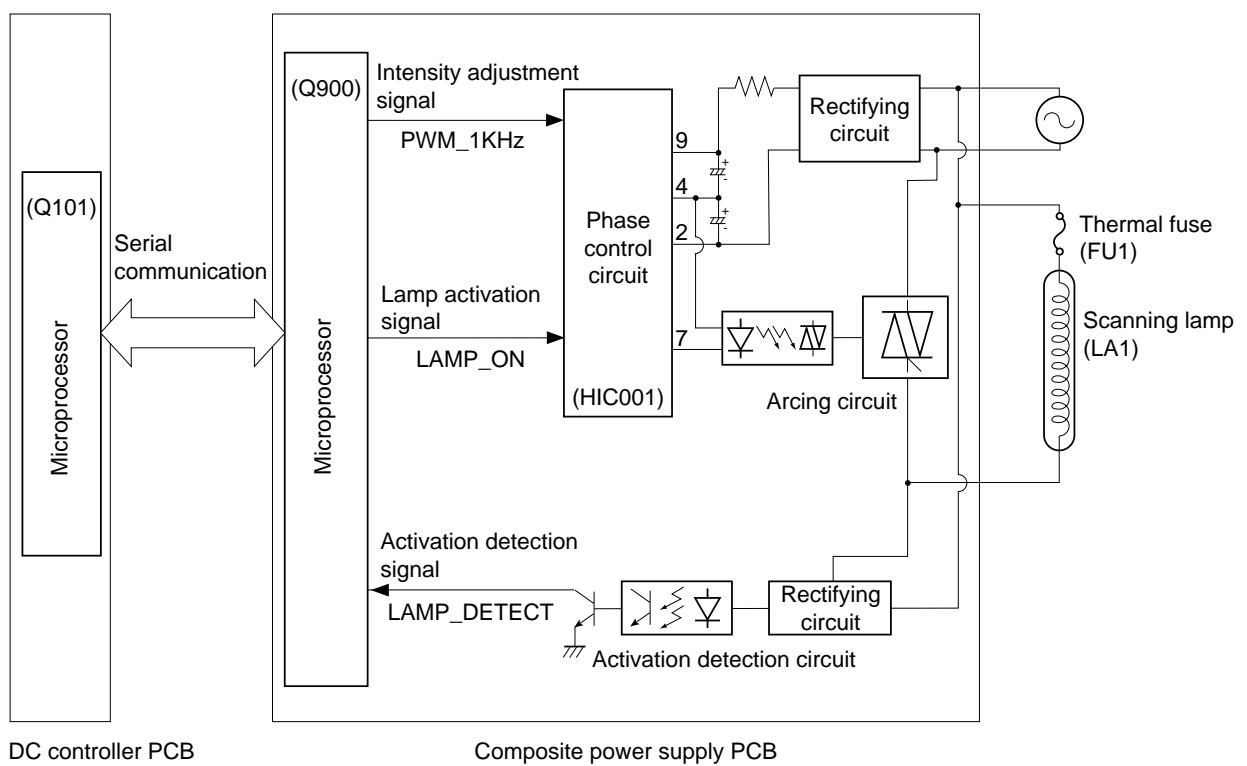

Figure 3-201

## 2. Operations

### a. Turning On/Off the Scanning Lamp

The DC controller PCB and the composite power supply exchange signals in serial communication to control the scanning lamp. According to the scanner lamp active voltage signal, the microprocessor (Q900) on the composite power supply PCB controls the intensity adjustment signal (PWM\_1KHz) and the lamp activation signal (LAMP\_ON) to turn on/off the scanning lamp (LA1).

When LAMP\_ON is '0',

- ↳ The phase control circuit turns on.
- ↳ The arcing circuit turns on.
- ↳ The scanning lamp turns on.

When LAMP\_ON is '1',

- ↳ The phase control circuit turns off.
- ↳ The arcing circuit turns off.
- ↳ The scanning lamp turns off.

b. Controlling the Intensity of the Scanning Lamp

The intensity of the lamp is controlled by the scanning lamp active voltage signal sent by the DC controller PCB in serial.

The microprocessor (Q900) on the composite power supply PCB sends the intensity adjustment signal (PWM\_1KHz) in response to the scanning lamp active voltage signal. In turn, the phase control circuit (HIC001) controls the voltage supplied to the scanning lamp.

The PWM\_1KHz signal varies according to settings made in service mode. In relation to the settings, the composite power supply PCB executes phase control so that variation will be between 10% and 90% in terms of pulse duty ratios and between 50.5 and 80 V for the 120V model (between 85.7 and 145.8 V for the 220/240V model) in terms of actual value.

The intensity during AE exposure remains a specific level, which is 56 V for the 120 V model (108.5 V for the 220/240V model) in terms of actual values.

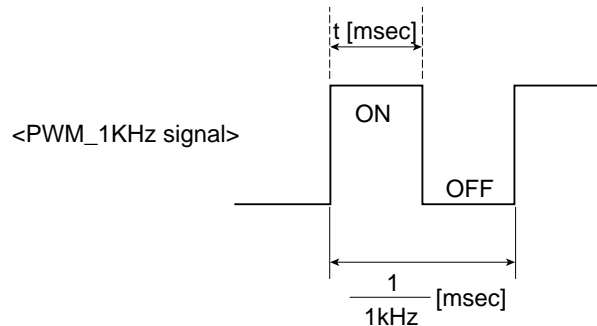

$$\text{Pulse duty} = t / \frac{1}{1k} \times 100 [\%]$$

Figure 3-202

**Related Service Mode**

38 (LAMP_ADJ)	Use it to adjust the intensity of the scanning lamp.
---------------	--

c. Monitoring the Activation of the Scanning Lamp

The activation detection signal (LAMP\_DETECT) is sent to the microprocessor (Q900) on the composite power supply PCB as long as the scanning lamp remains on.

The composite power supply PCB sends the lamp activation signal to the DC controller PCB in serial by way of monitoring the activation of the scanning lamp (LA1).

**Related Error Code**

E220

- The lamp activation detection signal is not detected for 1 sec or more although the scanning lamp activation signal has been sent.
- The lamp activation detection signal has been detected for 1 sec or more although the scanning lamp activation signal is not sent.

If an error has been detected, the power switch will be turned off after indicating an error code for 2 sec.

d. Scanning Lamp Intensity Auto Correction Control (ALVC control)

The machine automatically corrects the activation voltage of the scanning lamp to make up for the change in copy image quality caused by deterioration/wear of the photosensitive drum.

### III. DISASSEMBLY/ASSEMBLY

As needed, disassemble/assemble the machine with the following in mind:

1. **▲** Before starting the work, turn off the power switch and disconnect the power plug for safety.
2. Unless otherwise instructed, assemble the parts by reversing the steps used to disassemble it.
3. Identify the screws by type (length, diameter) and location.
4. Use the washers where necessary. (The screws used to mount the grounding wire and Varistors come with a washer to ensure electrical continuity.)
5. As necessary, cut the harness band.
6. As a rule, do not operate the machine with any of its part removed.
7. A few of the screws used are special screws (with wider thread intervals). Do not use any screws indiscriminately.

## A. Scanner Drive Assembly

### 1. Removing the Scanner/Lens Drive Motor

- 1) Remove the front lower cover.  
(See Chapter 7.III.A.2. "Removing the Front Lower Cover.")
- 2) Remove the developing assembly.  
(See Chapter 4.II.D.2. "Removing the Developing assembly.")
- 3) Remove the copyboard glass.  
(See Chapter 7.III.C.1. "Removing the Copyboard Glass.")
- 4) Remove the four screws [1], and detach the lens cover [2].

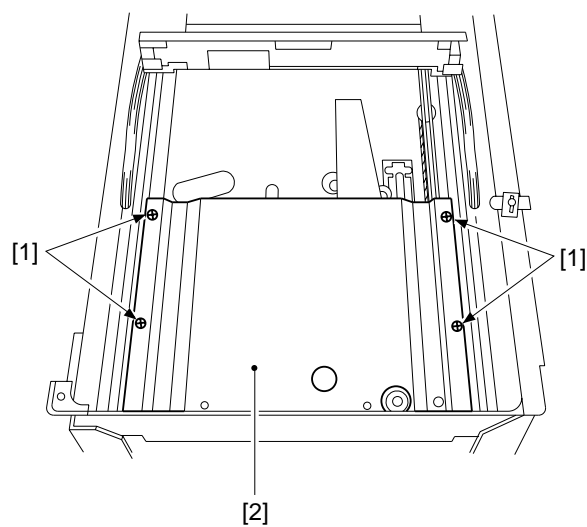

Figure 3-301

- 5) Disconnect the connector (J110) [3] from the DC controller PCB.

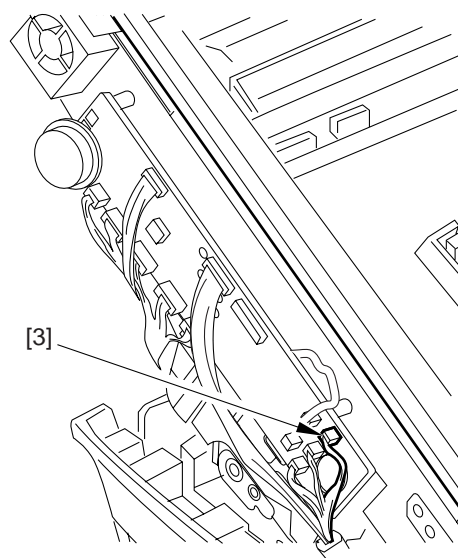

Figure 3-302

- 6) Open the machine's top unit farther, and hold it in position using the handle (about 30 mm in diameter) of a screwdriver.

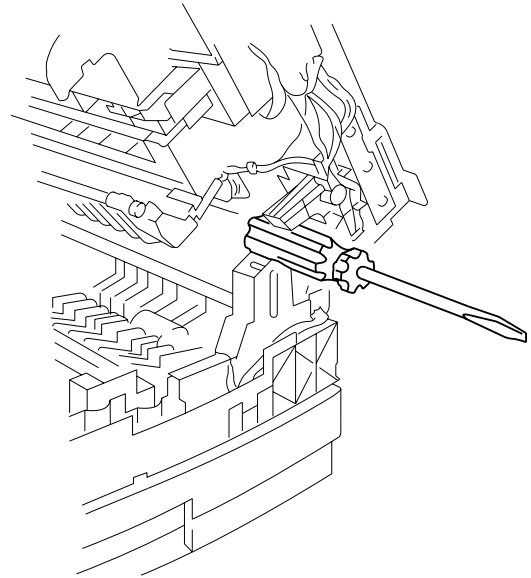

Figure 3-303

- 7) Remove the two fixing screws [4] from the scanner/lens drive motor [5].

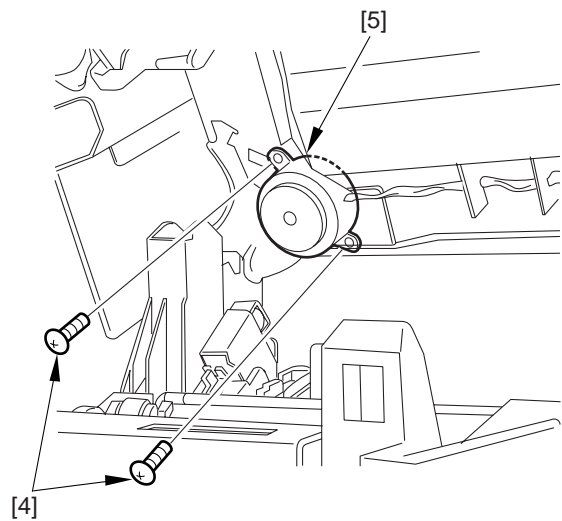

Figure 3-304

- 8) Free the top unit (by removing the screw-driver), and close the top unit.
- 9) Remove the E-ring [6]; then, lift the cable drive pulley [7] slightly, and detach the scanner/lens drive motor [5].

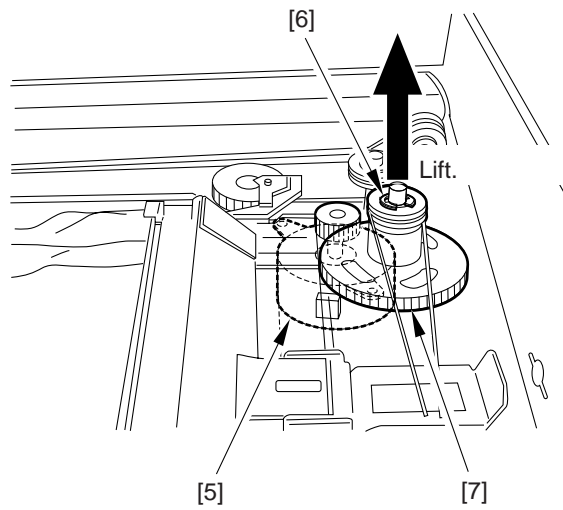

Figure 3-305



2. Outline of the Scanner Drive Cable

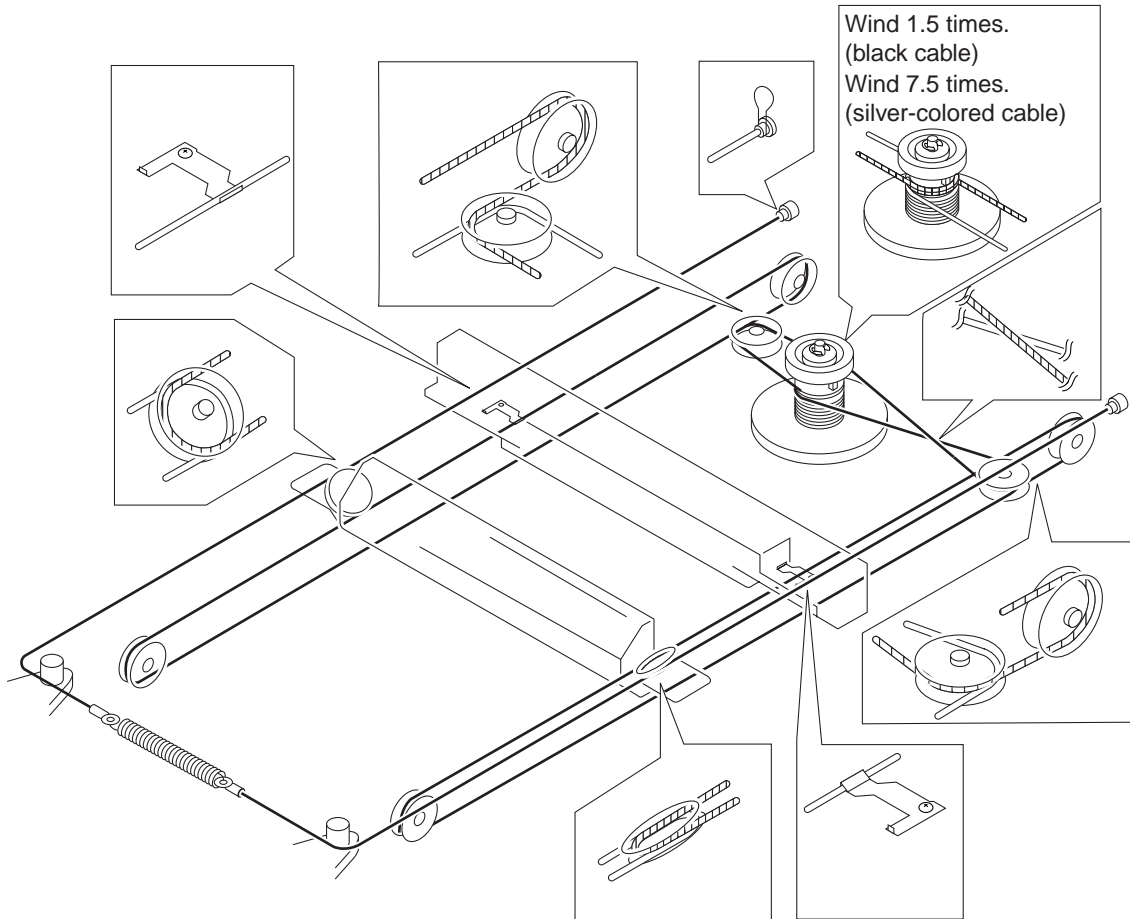

Figure 3-306

### 3. Routing the Scanner Drive Cable

#### a. Before Starting the Work

Prepare the following:

- Mirror positioning tool
- Cable clip
- Adhesive tape

1) Set the mirror positioning tool as shown.

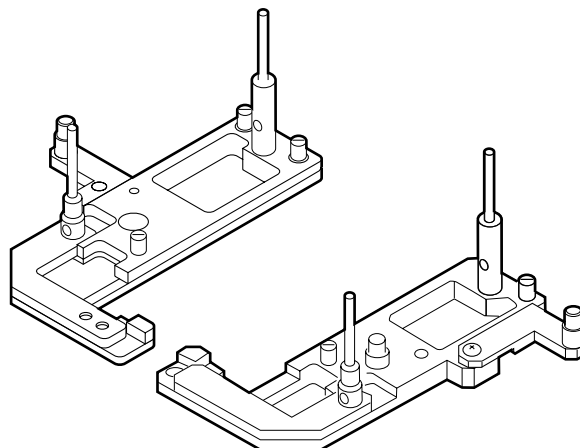

Figure 3-307

- 2) Prepare about five strips of adhesive tape (each one about 20 × 50 mm).
- 3) Remove the copyboard glass. (See Chapter 7.III.C.1. “Removing the Copyboard Glass.”)
- 4) Disconnect the connectors (J101, J131) [1] from the DC controller PCB.

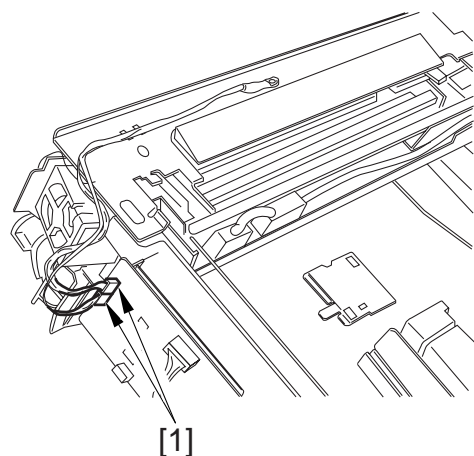

Figure 3-308

- 5) If the machine is equipped with an ADF, free the hook [2], and disconnect the two relay connectors [3] from the left upper stay [4].

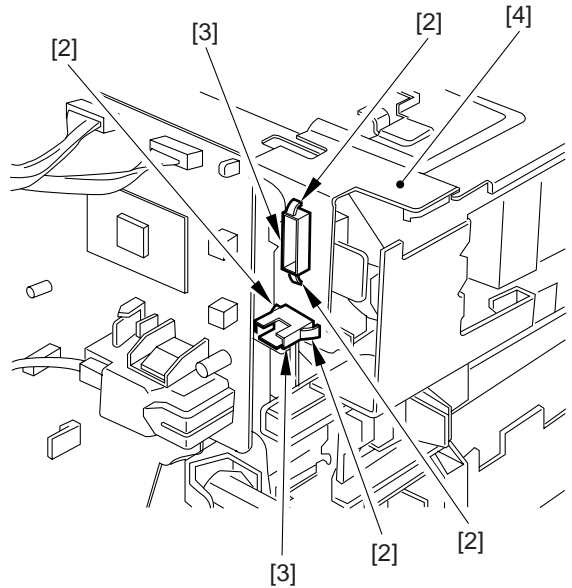

Figure 3-309

- 6) Remove the three screws [5], and detach the left upper stay [4].

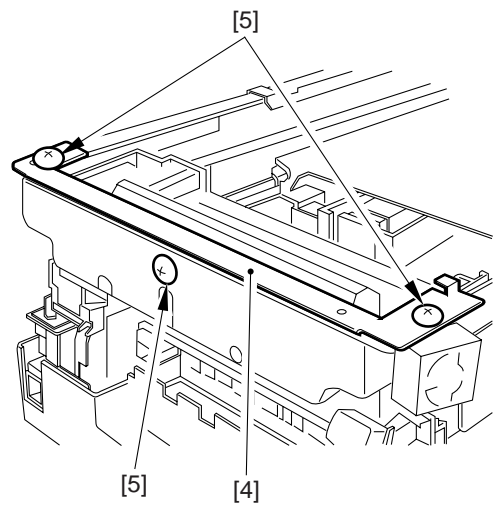

Figure 3-310

- 7) Remove the four screws [6], and detach the lens cover [7].

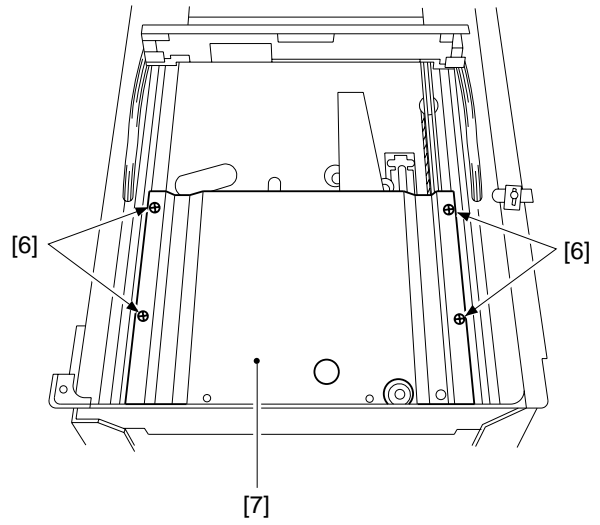

Figure 3-311

b. Routing the Reversing Cable

- 1) Wind the reversing cables (silver-colored) [2] on the cable drive pulley [1] 7.5 times with the longer end on top; then, secure it in position with a cable clip [3].

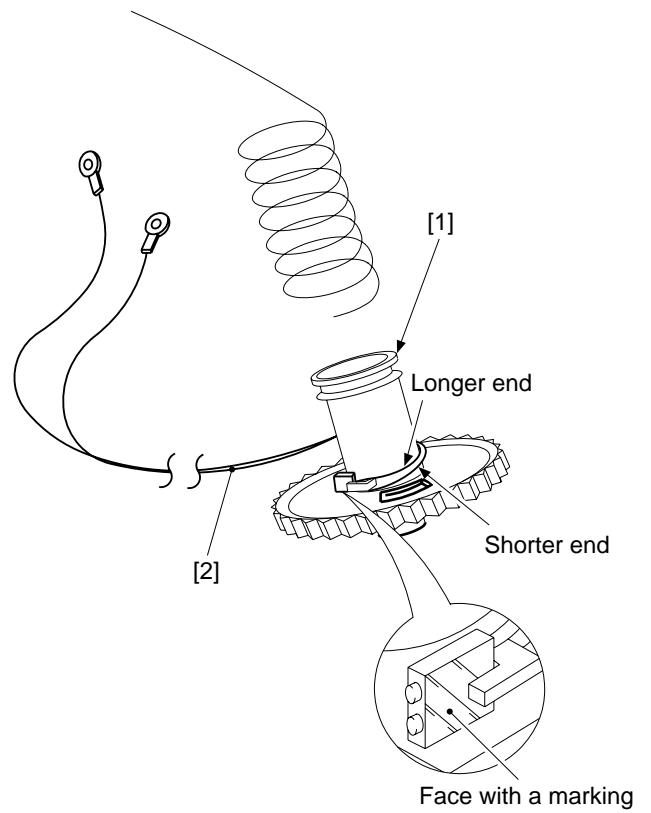

Figure 3-312

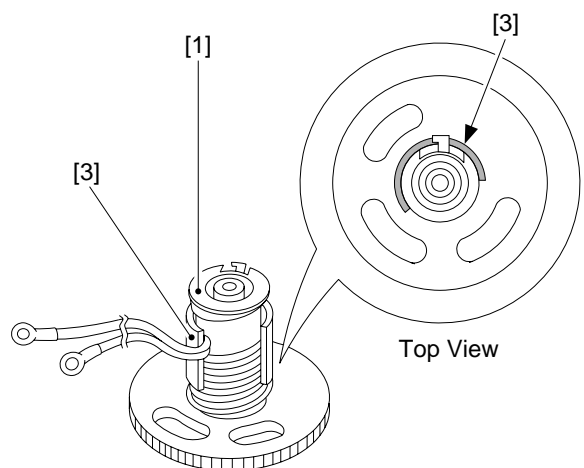

Figure 3-313

- 2) Put the cable drive pulley [1] into the shaft [4], and secure it in position with an E-ring [5].

When putting the cable drive pulley into the shaft, be sure that the hook is at the front.

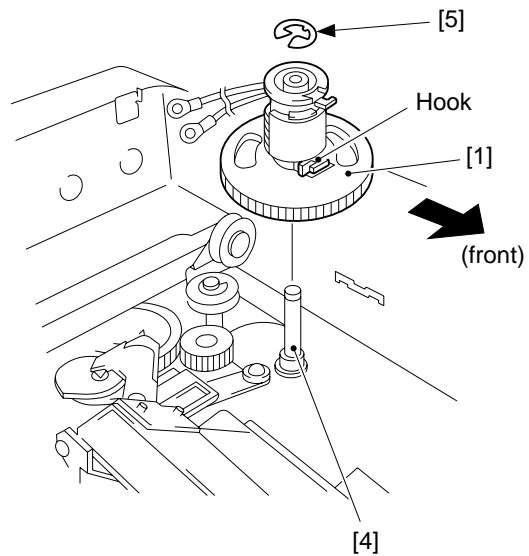

Figure 3-314

- 3) Hook the shorter end [6] on the pulley [7].

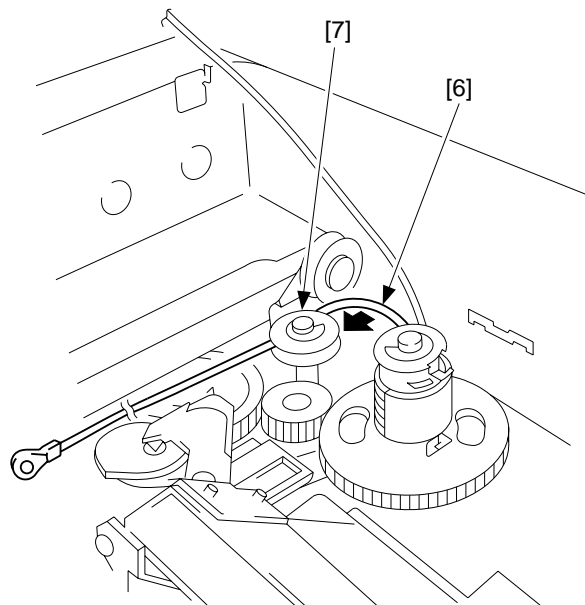

Figure 3-315

- 4) Lead the shorter end [6] under the No. 1 mirror mount [8] and the No. 2/3 mirror mount [9]; then, hook it on the left rear pulley [10] and the pulley [11] of the No. 2/3 mirror mount.

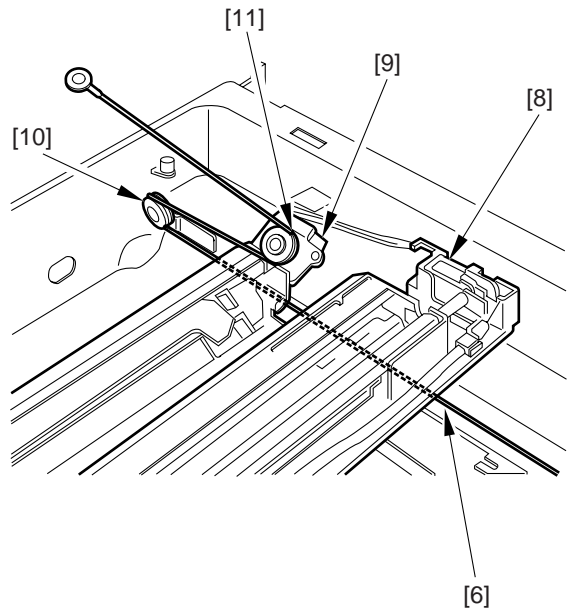

Figure 3-316

- 5) After fitting the shorter end [6] on the cable hook [12], secure its end with adhesive tape [13]. Be sure that the secured end of the cable is found where the hole in the left side plate and the tip of the cable matches.

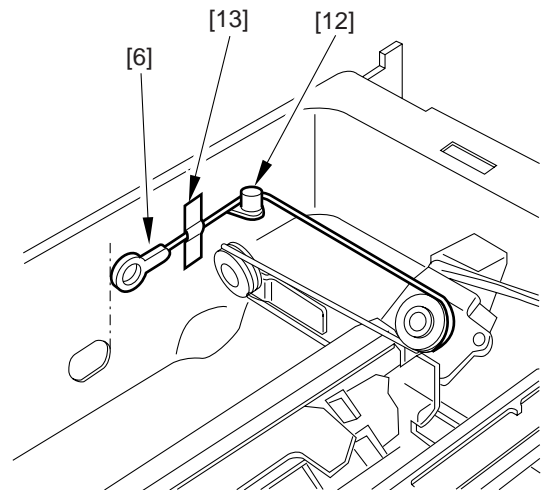

Figure 3-317

- 6) Lead the longer end [14] along the cable drive pulley, and hook it on the pulley [15] on the right front side.

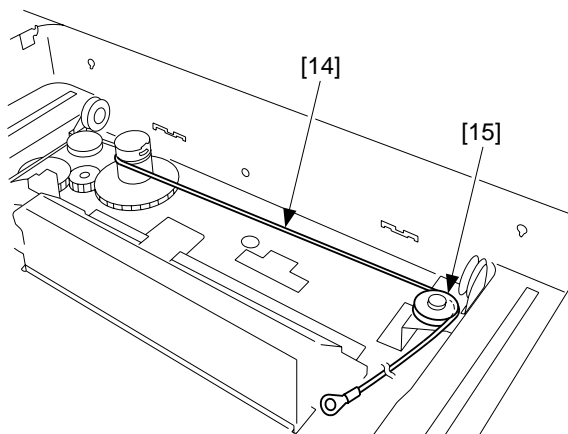

Figure 3-318

- 7) Lead the longer end [14] under the No. 1 mirror mount [8] and the No. 2/3 mirror mount [9]; then, hook it on the pulley [16] on the left front side and the pulley [17] of the No. 2/3 mirror mount.

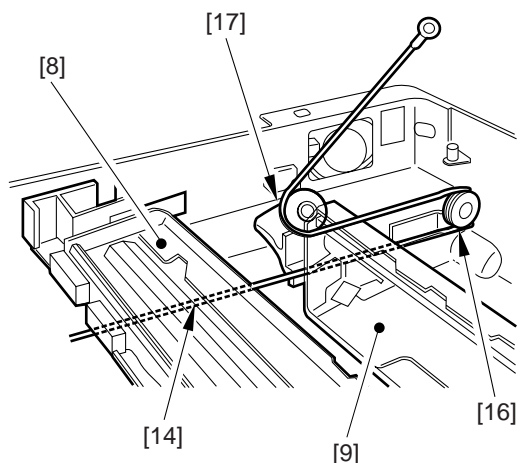

Figure 3-319

- 8) Hook the longer end [14] on the cable hook [18]; then, secure its end to the left side with adhesive tape [19]. Be sure that the secured end of the cable is found where the hole in the left side plate and the tip of the cable matches.

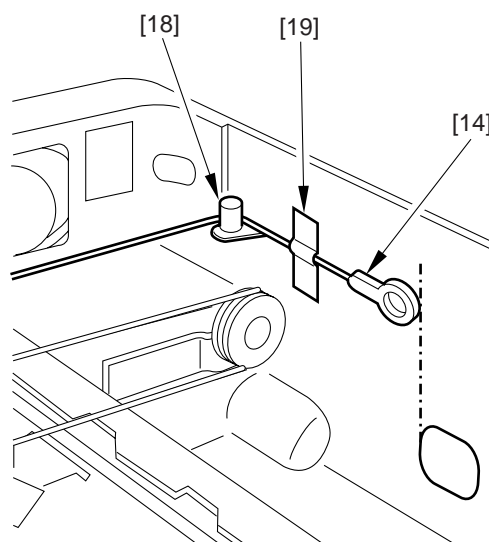

Figure 3-320



c. Routing the Forwarding Cable

- 1) Fit the longer end forwarding cable (black) [2] on the top hook of the cable drive pulley [1], and wind it 1.5 times. Then, secure the shorter end [3] as shown with adhesive tape [4].

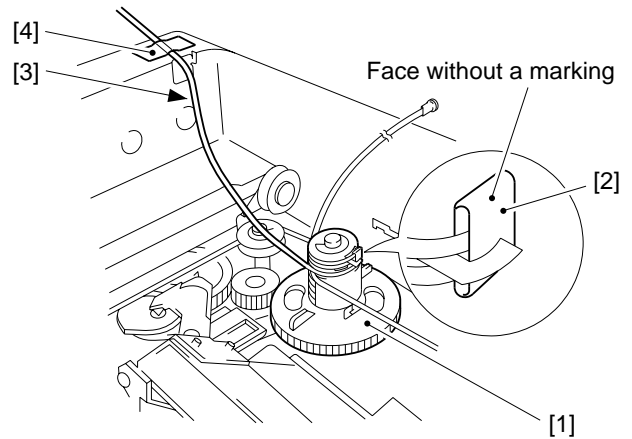

Figure 3-321

- 2) Lead the longer end [5] along the cable drive pulley [1] as shown, and hook it on the pulley [6] on the right front side.

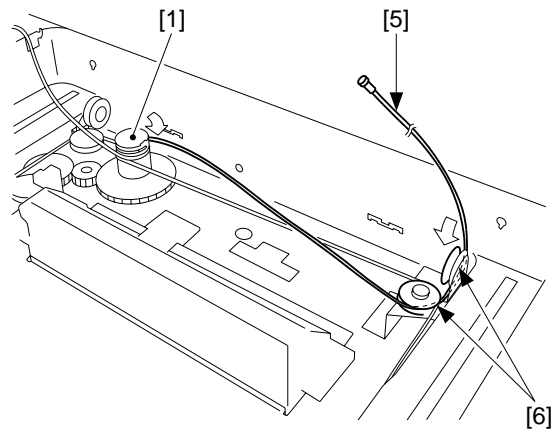

Figure 3-322

- 3) Lead the longer end [5] under the No. 1 mirror mount [7]; then, hook it on the pulley [8] of the No. 2/3 mirror mount, and lead it between the No. 1 mirror mount [7] and the scanning lamp [9].

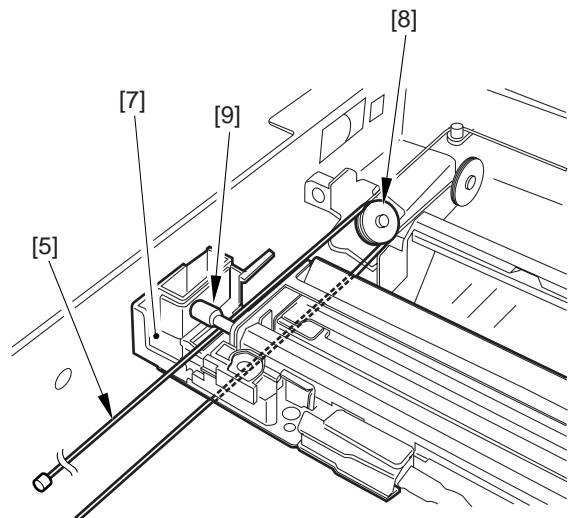

Figure 3-323

- 4) Hook the end of the longer end [5] on the hole [10] on the right side.

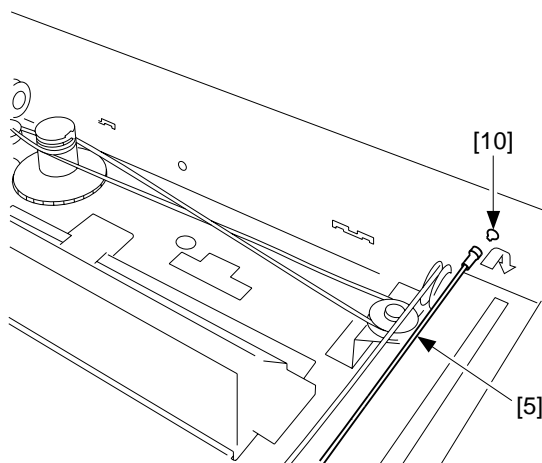

Figure 3-324

- 5) Free the shorter end [3], and hook it on the pulley [11] on the right rear side.

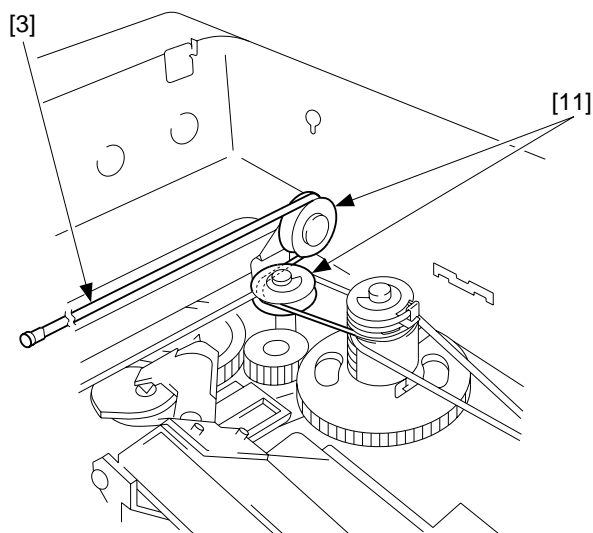

Figure 3-325

- 6) Lead the shorter end [3] under the No. 1 mirror mount [7], and hook it on the pulley [12] of the No. 2/3 mirror mount as shown; then, lead it between the No. 1 mirror mount [7] and the scanning lamp [9].

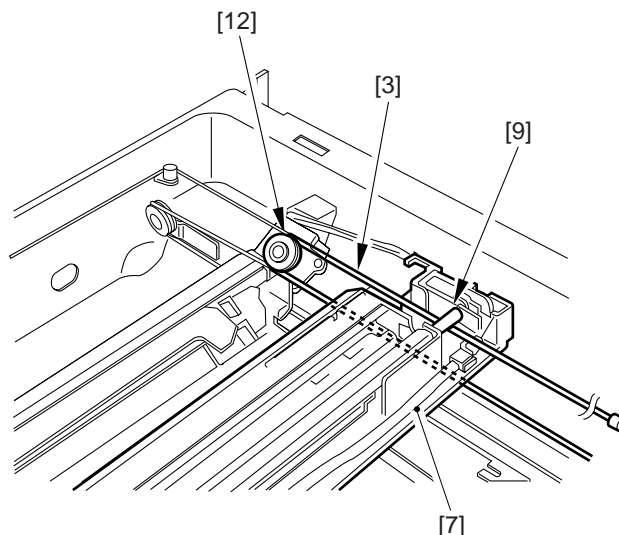

Figure 3-326

- 7) Hook the end of the shorter end [3] on the hole [13] on the right side.

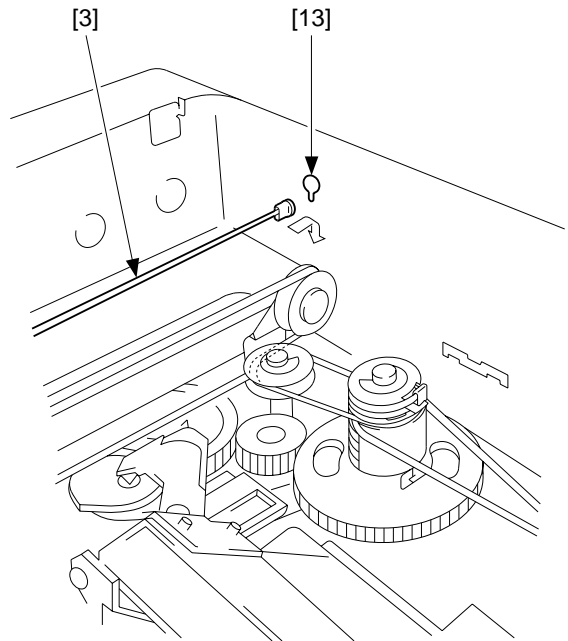

Figure 3-327

- 8) Free the shorter end [3] and the longer end [5] (reversing cable), and connect both with a spring [14]; then, fit the stopper [15].

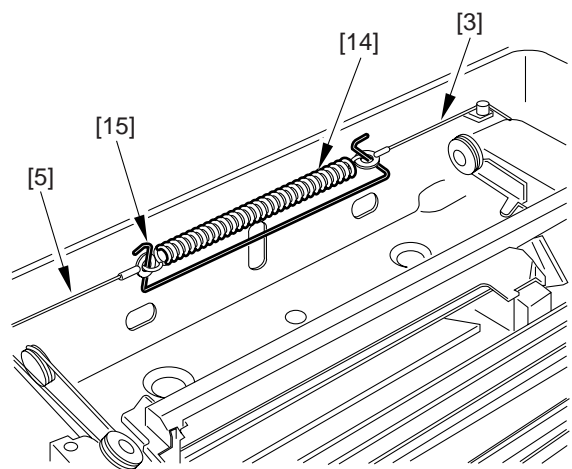

Figure 3-328

- 9) Detach the pulley clip [16] from the cable drive pulley [1].

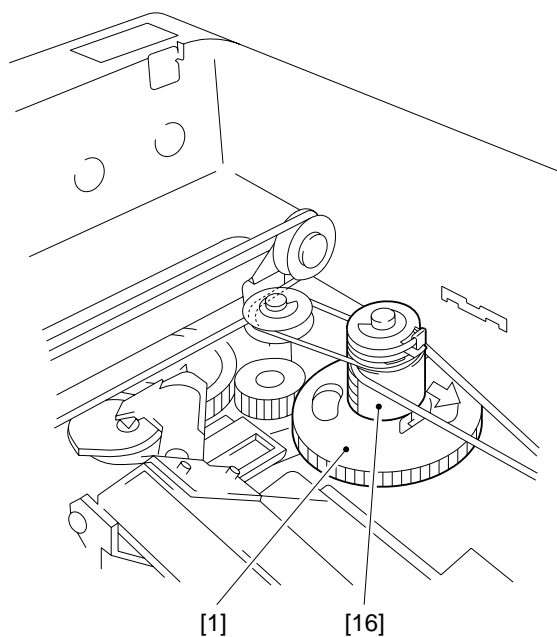

Figure 3-329

- d. Positioning the No. 1 Mirror Mount  
 1) Fix the rear and the front of the No. 1 mirror mount [1] temporarily to the metal fixing [2] of the forwarding cable.

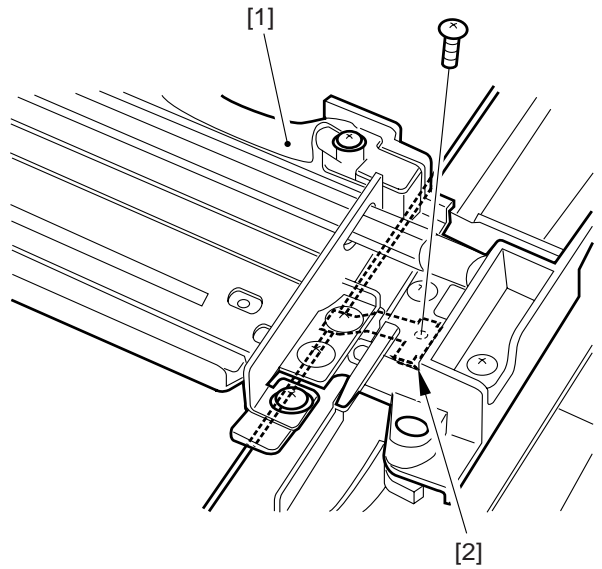

Figure 3-330 (front)

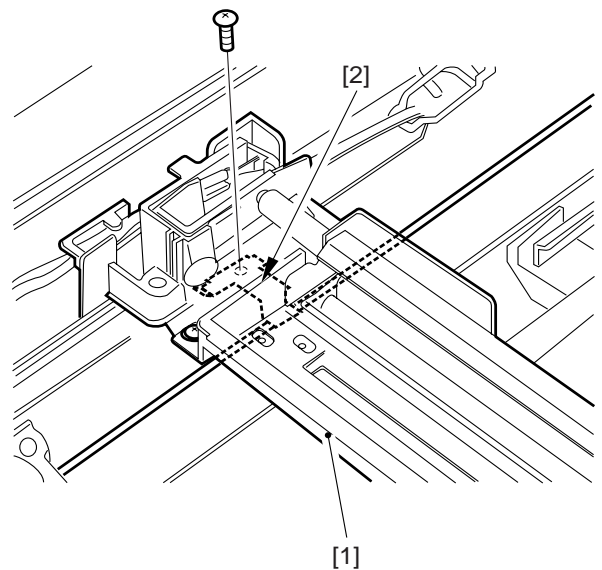

Figure 3-331 (rear)

- 2) Turn the cable drive pulley [4] so that the three shafts [3] of the mirror positioning tool for rear and front is as shown.

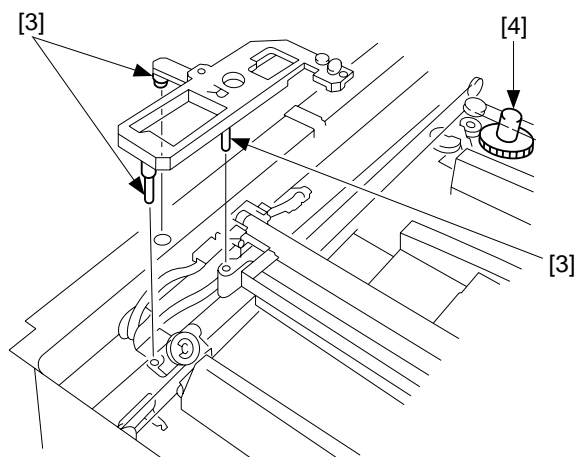

Figure 3-332 (rear)

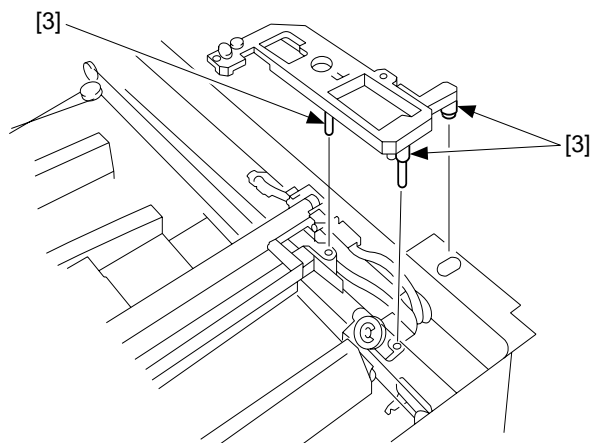
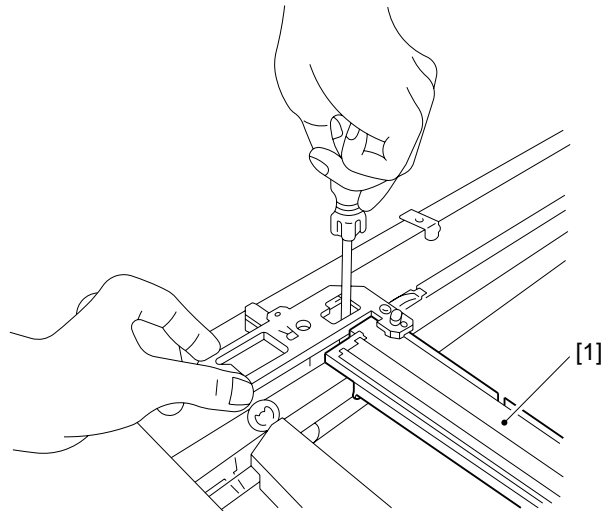
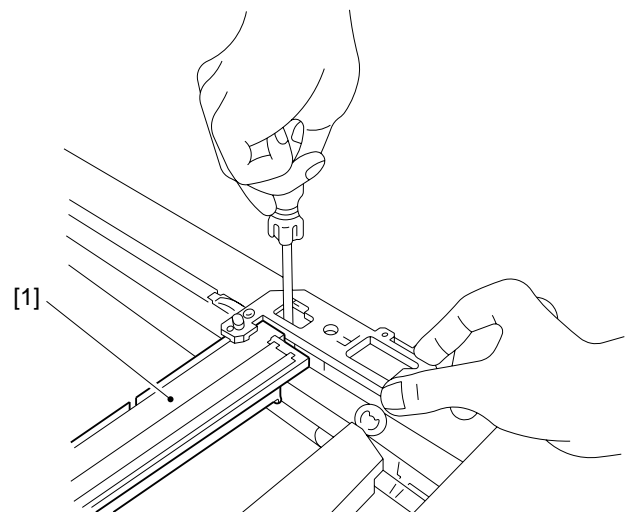

Figure 3-333 (front)

- 3) While keeping the condition of step 2), tighten the positioning screw on the rear and front of the No. 1 mirror mount [1].



**Figure 3-334 (rear)**



**Figure 3-335 (front)**

## B. Lens Drive Assembly

### 1. Removing the Lens Cable

- 1) Turn on the power; when the lens has moved to the Direct position, disconnect the power plug.
- 2) Remove the copyboard glass.  
(See Chapter 7.III.C.1. "Removing the Copyboard Glass.")
- 3) Remove the main drive assembly.  
(See Chapter 7.III.D.2. "Removing the Main Drive Assembly.")
- 4) Remove the four screws [1], and detach the lens cover [2].

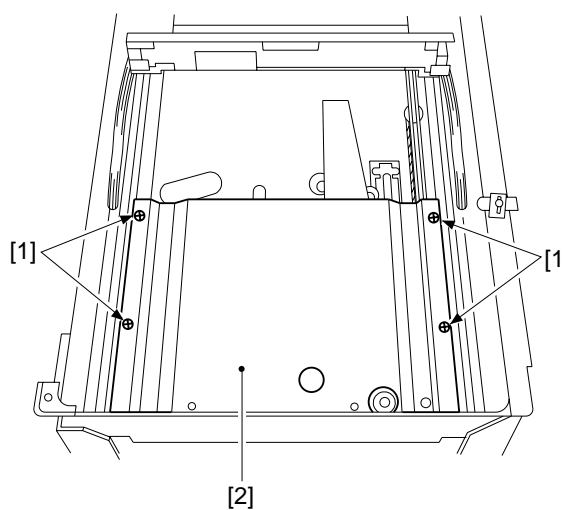

Figure 3-336



- 5) Mark the position of the lens cable fixing plate [3] and the lens mount [4] with a scribe.

**Caution:**

When routing the lens cable, be sure to refer to the marking made with a scribe.

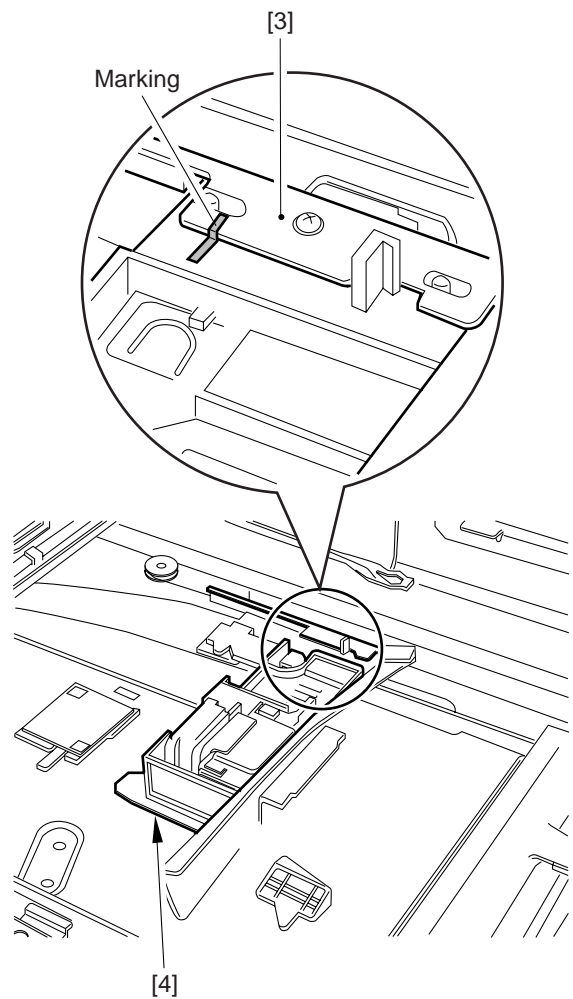

**Figure 3-337**

- 6) Disengage the lever [5] of the No. 4/5 mirror mount and the gear [6].

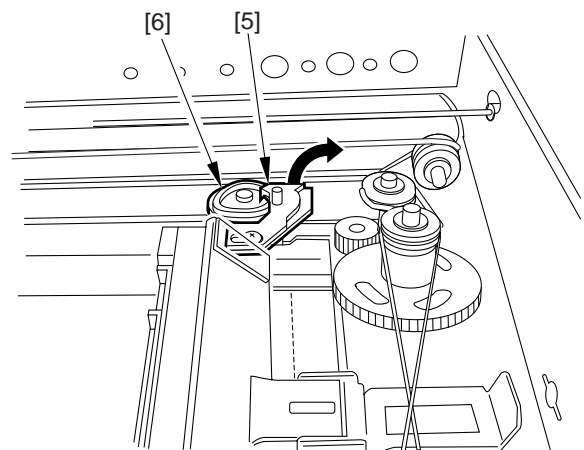

**Figure 3-338**

- 7) Remove the screw [7], and detach the cam gear [6] and the cable retainer [8].

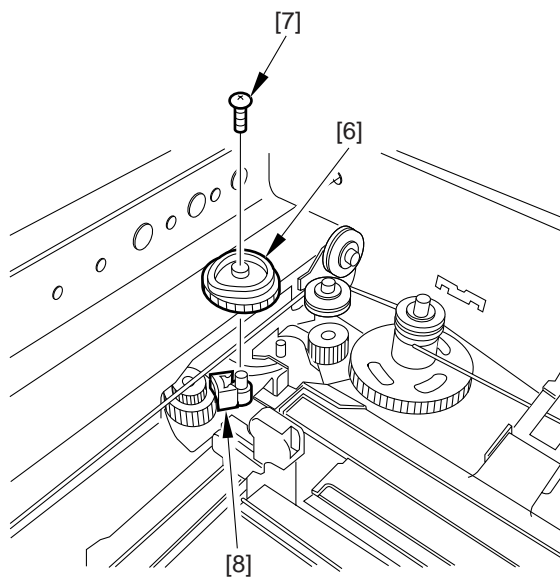

Figure 3-339

- 8) Holding the middle of the No. 1 mirror mount [9], move it to the center of the machine.

**Caution:**  
Do not hold the reflecting plate.

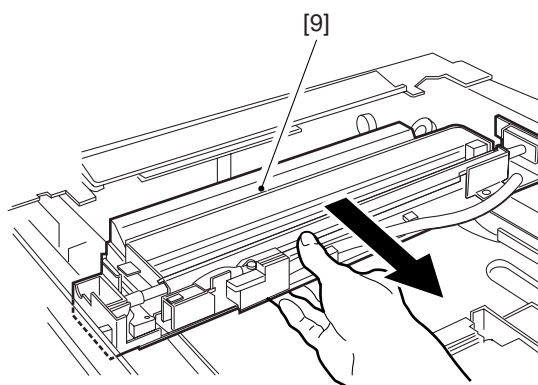

Figure 3-340

- 9) Remove the spring [10].

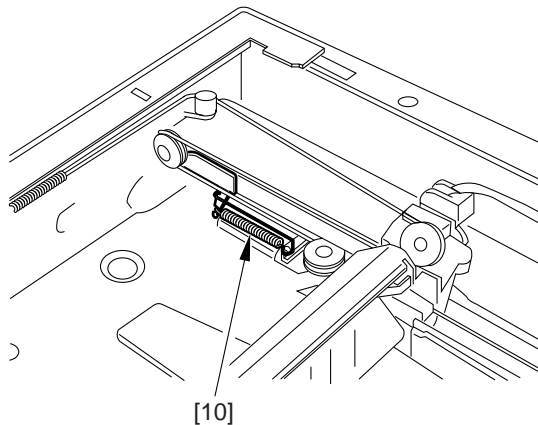

Figure 3-341

- 10) Remove the screw [11], and detach the lens cable fixing plate [12].

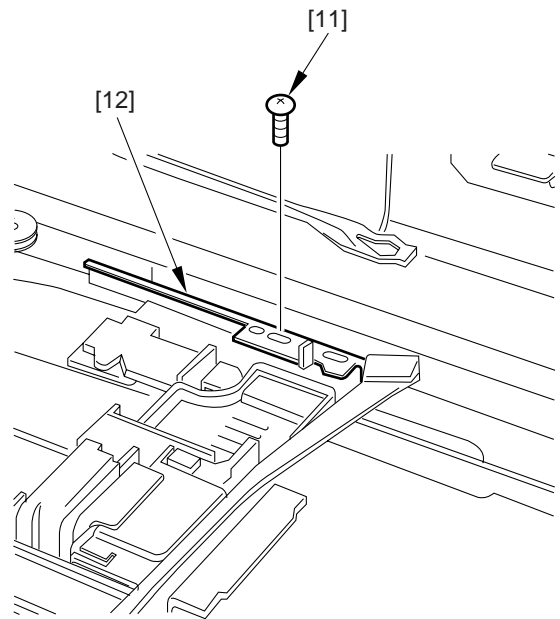

Figure 3-342

- 11) Free the lens cable [13] from the lens cable fixing plate [12]; then, detach the lens cable from the machine.

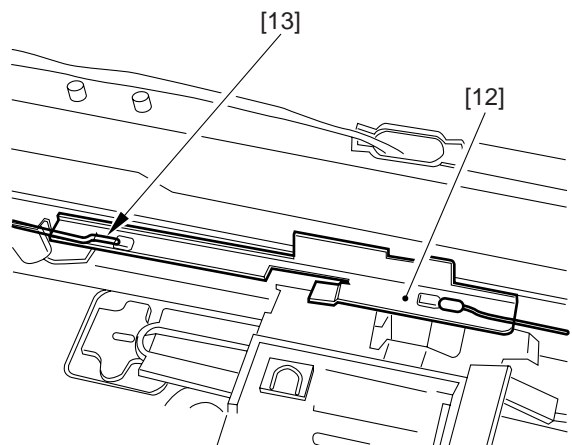
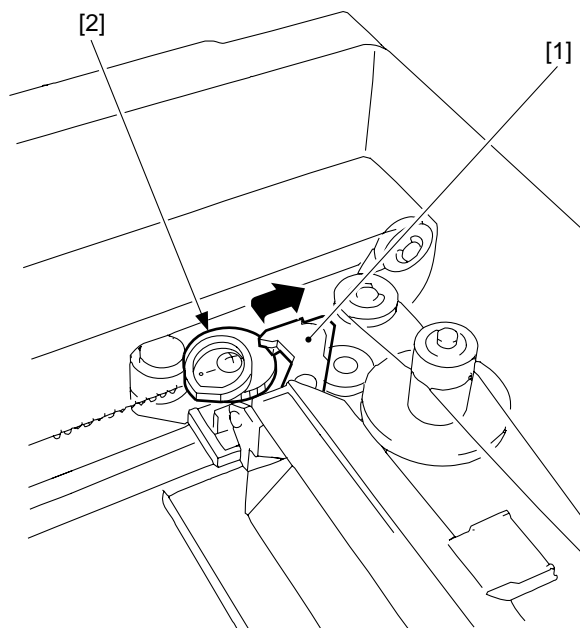

Figure 3-343

**2. Routing the Lens Cable**

- 1) After routing the lens cable, keep the lever [1] of the No. 4/5 mirror mount disengaged from the cam gear [2] (so that the lever will not come into contact when the cam gear rotates).



**Figure 3-344**

- 2) While keeping the condition in step 1), turn on the power; when the No. 1 mirror mount and the lens stopped moving, turn off the power.
  - The lens will move to the Direct position.
- 3) Check to make sure that the tip of the lever [1] of the No. 4/5 mirror mount and the marking [3] on the top face of the cam gear [2] match; then, engage the lever [1] and the cam gear [2].

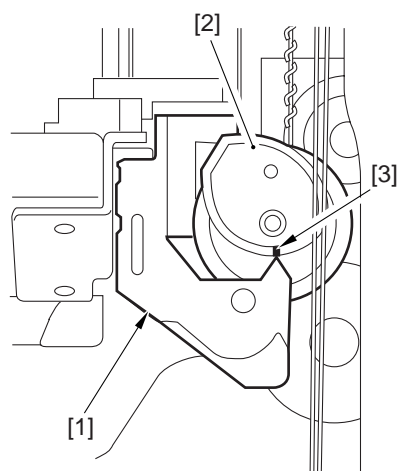

**Figure 3-345**

- 4) If the tip of the lever [1] and the marking on the cam gear [2] do not match, remove the fixing screw [4] of the cam gear [2] and detach the cam gear; then, mount the cam gear once again so that the marking on it and the tip of the lever match.

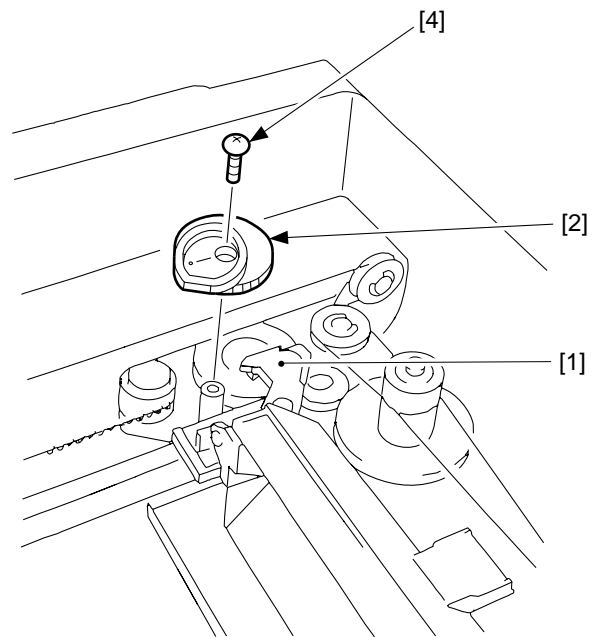

Figure 3-346

## C. Exposure System

### 1. Removing the Scanning Lamp

- 1) Disconnect the power plug.
- 2) Remove the copyboard glass.  
(See Chapter 7.III.C.1. "Removing the Copyboard Glass.")
- 3) Holding the middle of the No. 1 mirror mount [1], move the No. 1 mirror mount [1] to the right by about 5 cm.

**Caution:**

Do not hold the reflecting plate.

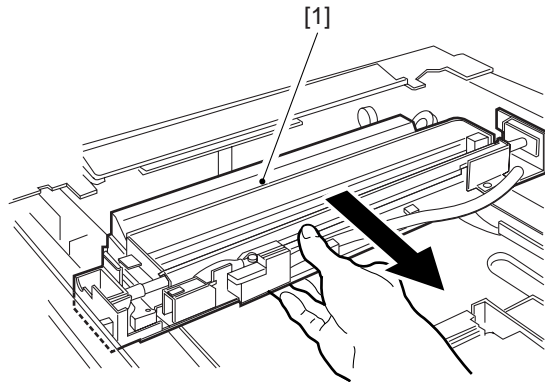

Figure 3-347

- 4) Free the harness [3] from the guide [2]; then, remove the screw [4], and detach the reflecting plate [5].

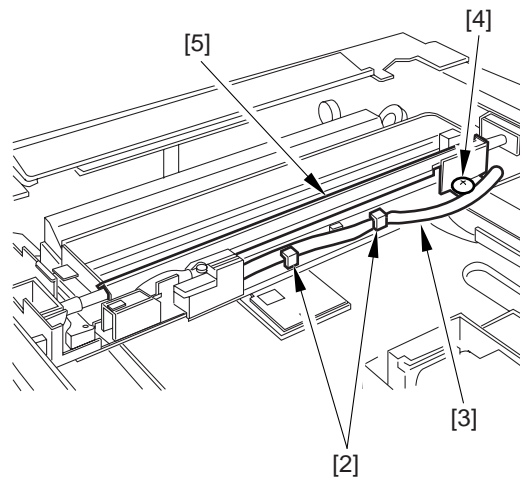
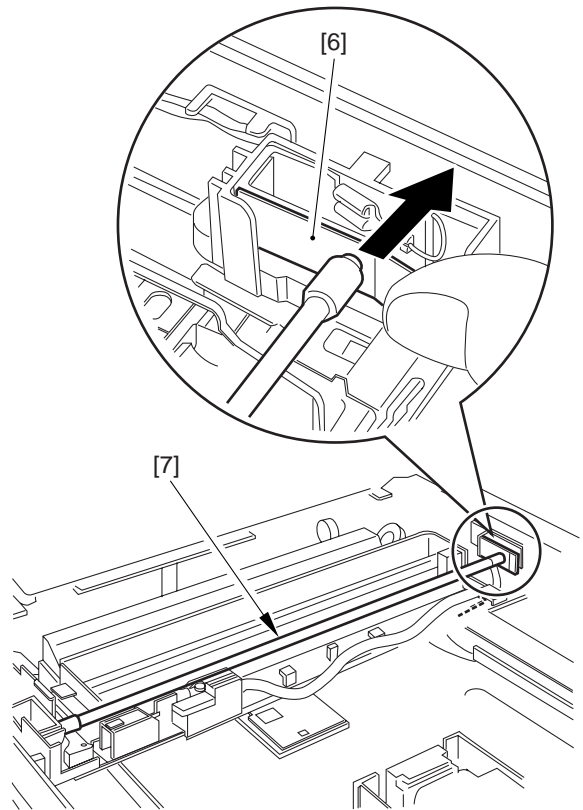

Figure 3-348

- 5) While pushing the electrode mount [6] found at the rear of the machine in the direction of the arrow, detach the scanning lamp [7].

**Caution:**

1. Do not start the work if the scanning lamp is hot.
2. Do not leave fingerprints on the surface of the scanning lamp.
3. If the surface of the scanning lamp is soiled, dry wipe it.



**Figure 3-349**

## 2. Points to Note When Mounting the Lamp

When mounting the scanning lamp, be sure that the logo mark (or the name of the manufacturer) is toward the front. Further, be sure that the protrusion near the middle of the lamp is as shown.

**Caution:**

- Do not touch the lamp portion.
- If you have replaced the scanning lamp, be sure to perform intensity adjustment (p. 11-42) and AE adjustment (p. 11-44).

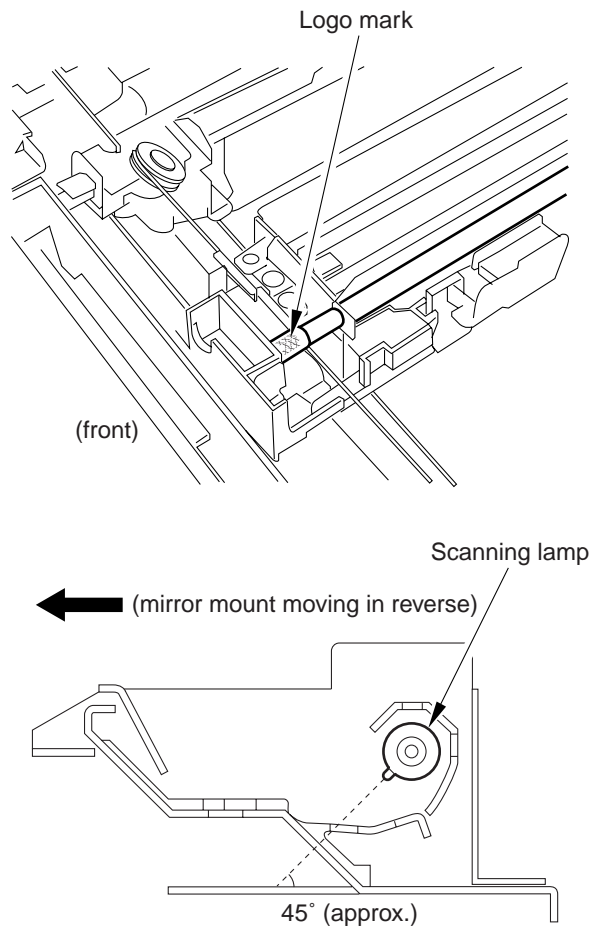

**Figure 3-350**



### 3. Removing the Thermal Fuse

- 1) Disconnect the power plug.
- 2) Remove the copyboard glass.  
(See Chapter 7.III.C.1. "Removing the Copyboard Glass.")
- 3) Remove the two screws [1], and detach the thermal fuse [2].

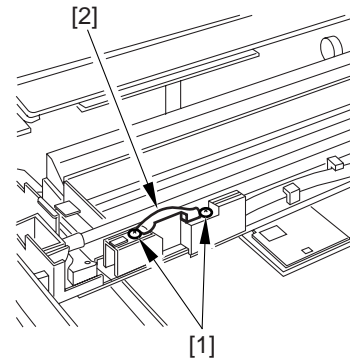

Figure 3-351

### 4. Points to Note When Mounting the Fuse

When mounting the thermal fuse, be sure that the thermal fuse is oriented as shown.

Make sure that the fuse is in contact with the reflecting plate.

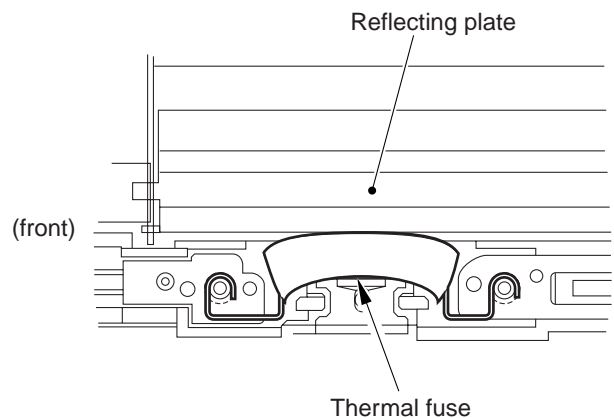

Figure 3-352

### 5. Removing the Thermistor Unit

- 1) Remove the top cover.  
(See Chapter 7.III.A.1. "Removing the Top Cover.")
- 2) Disconnect the connector (J131) [1] from the DC controller PCB; remove the screw [2], and detach the thermistor unit [3].

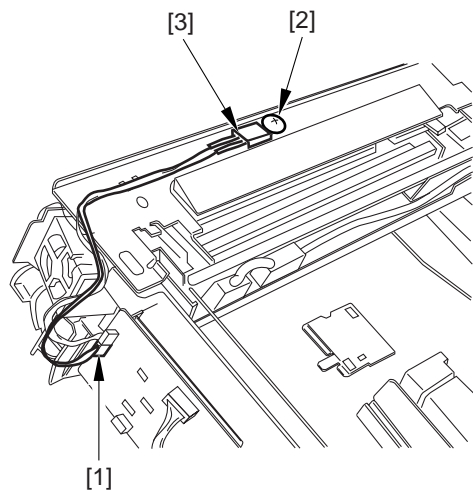

Figure 3-353

---

# CHAPTER 4

---

## IMAGE FORMATION SYSTEM

---

This chapter discusses the principles of how images are formed. It also explains the timing at which the various units involved in image formation are operated, and shows how they may be disassembled/assembled and adjusted.

I.	IMAGE FORMATION SYSTEM ...	4-1	II.	DEVELOPING ASSEMBLY /CLEANING ASSEMBLY .....	4-27
A.	Outline .....	4-1	A.	Outline .....	4-27
B.	Timing Chart for the Image Formation System .....	4-3	B.	Detecting the Level of Toner .....	4-28
C.	Primary Charging Roller Bias Control .....	4-4	C.	Detecting Waste Toner .....	4-30
D.	Controlling the Transfer Roller Bias .....	4-9	D.	Primary Charging Roller Cleaning Control .....	4-31
E.	Controlling the Developing/ Separation Static Eliminator Bias .....	4-12	III.	DISASSEMBLY/ASSEMBLY .....	4-33
F.	Measuring the Density of Originals .....	4-18	A.	Drum Unit .....	4-34
G.	Controlling the Pre-Exposure Lamp .....	4-24	B.	Transfer Charging Assembly .....	4-38
H.	Controlling the Side Blanking Mechanism .....	4-26	C.	Blank Exposure .....	4-39
			D.	Developing Assembly .....	4-43



# I. IMAGE FORMATION SYSTEM

## A. Outline

The major functions of the image formation system are as follows:

Item	Description
Primary charging roller bias control	DC constant voltage control: on/off DC voltage level switching DC voltage level auto correction
Transfer roller bias control	DC constant voltage control: on/off DC constant current control (ATVC, cleaning bias) Voltage level control Polarity switching control
Developing/separation static eliminator bias control	DC constant voltage control: on/off AC constant voltage control: on/off DC voltage level control
Density control	Developing DC bias control
Pre-exposure control	Pre-exposure lamp
Blank exposure control	Side blanking exposure lamp
Toner level detection	Level detection by a waste toner sensor
Waste toner case full detection	Detection by a waste toner sensor
Primary charging roller cleaning	Auto cleaning by the cleaning pad

**Table 4-101**

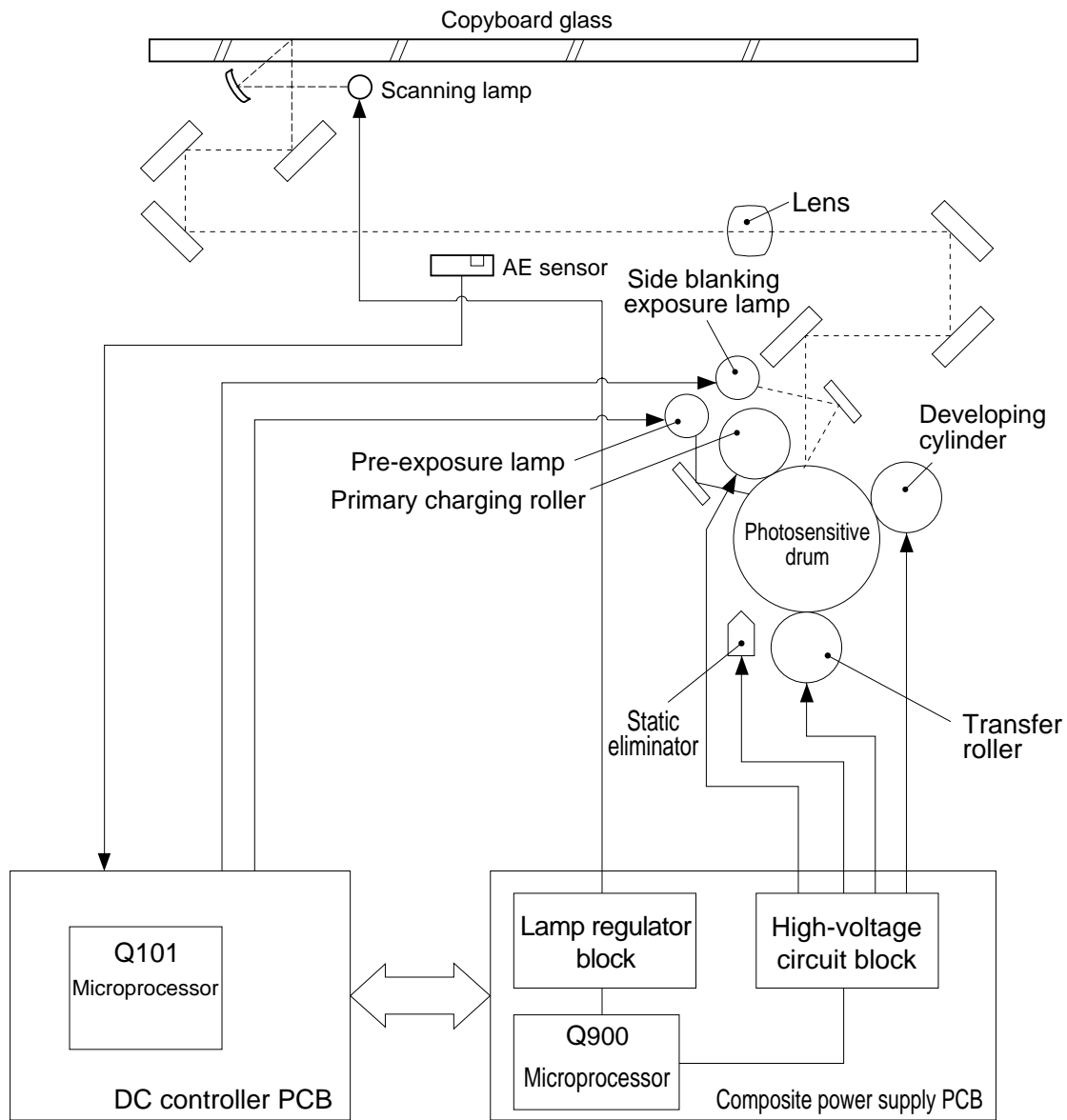

Figure 4-101

## B. Timing Chart for the Image Formation System

Basic Sequence of Operations (Direct, 2 copies, continuous)

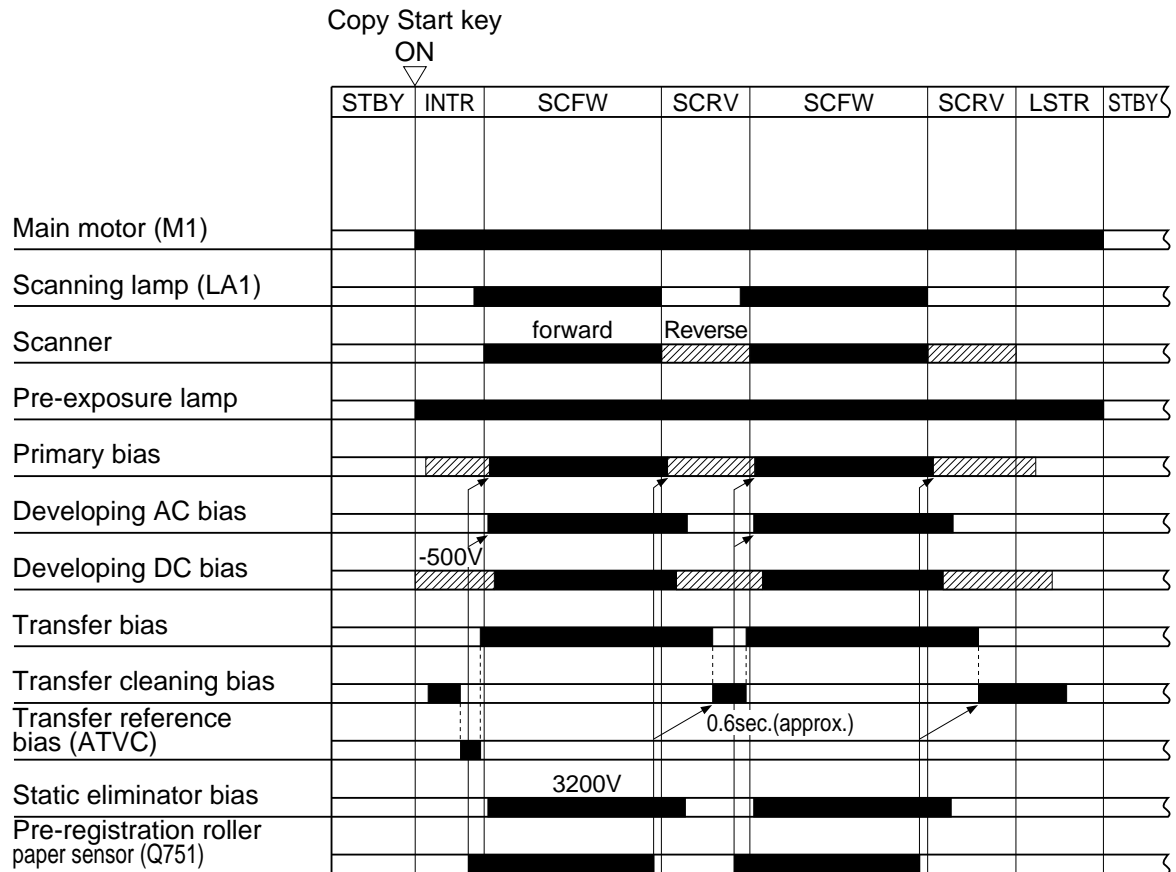

Figure 4-102

## C. Primary Charging Roller Bias Control

### 1. Outline

Figure 4-103 shows the circuit used to control the voltage applied to the primary charging roller, and has the following functions:

- Turning on and off the DC bias.
- Controls the DC bias to a constant voltage.
- Switching the level of the DC bias.
- Corrects the level of the DC bias automatically.

The level of the DC bias applied to the primary charging roller is switched between image area and non-image area.

#### Reference:

The level of the DC bias is as follows:

Image area:  $-1376\text{ V} \pm (\text{correction value by APVC}) \pm (\text{correction value * by density mode})$

Non-image area:  $-900\text{ V} \pm (\text{correction value by APVC})$ ; area between sheets  
 $-1000\text{ V} \pm (\text{correction value by APVC})$ ; cleaning area by transfer  
 $-600\text{ V} \pm (\text{correction value by APVC})$ ; trailing edge area

\*See p. 4-16.



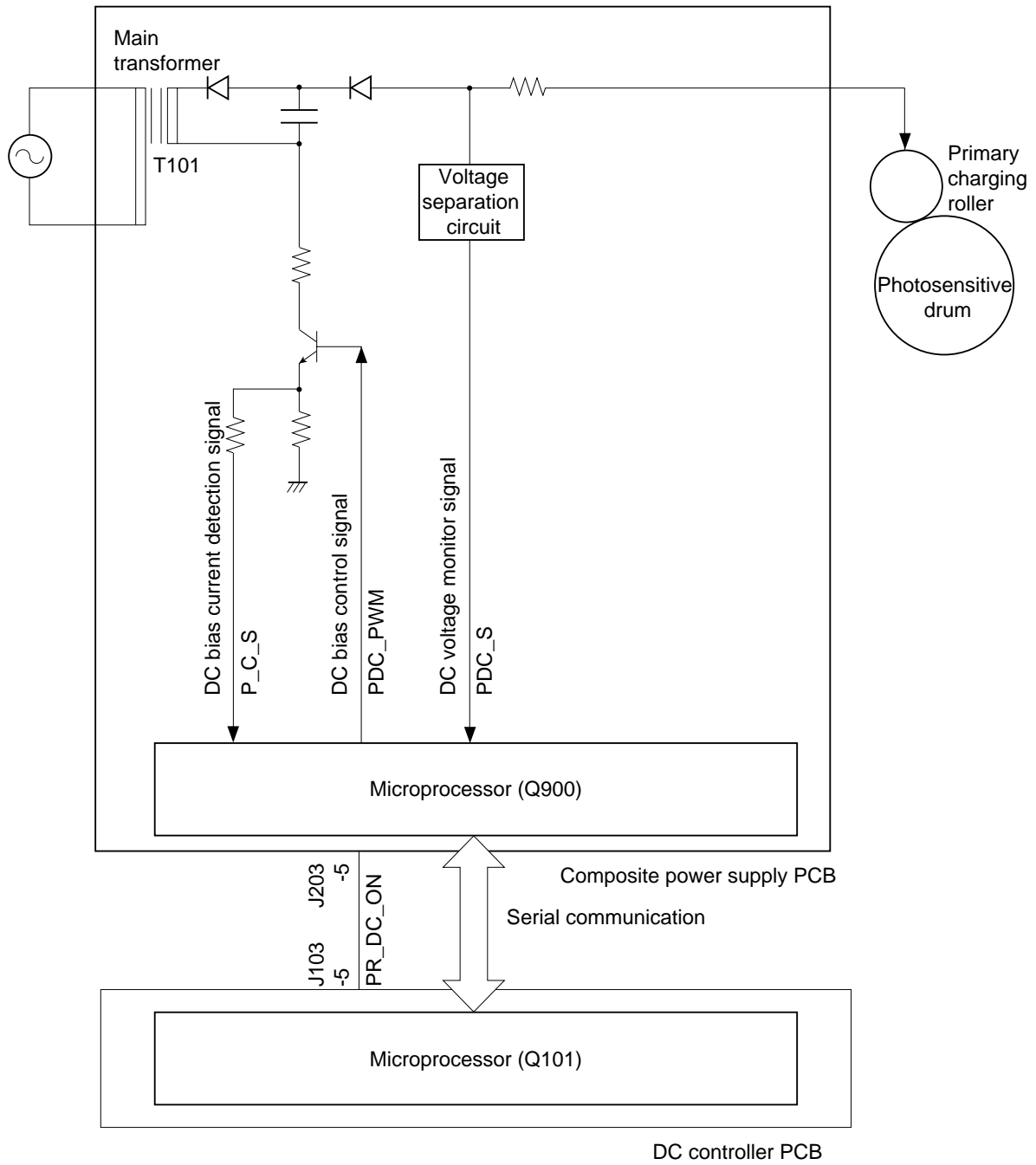

Figure 4-103

**2. Operations**

**a. Turning On and Off the DC Bias**

The DC bias applied to the primary charging roller is turned on or off by the serial communication signal and the primary charging bias ON signal (PR\_DC\_ON) from the DC controller PCB.

When the Copy Start key is pressed, the DC bias ON signal (serial) and the primary charging bias ON signal (PR\_DC\_ON) are sent. The microprocessor (Q900) on the composite power supply PCB generates the DC bias control signal (PDC\_PWM) based on the combination of the serial signal and the PR\_DC\_ON signal, applying a DC bias to the primary charging roller.

	DC bias ON signal (8-bit signal communication)		PR_DC_ON (J103-5)
	bit0	bit1	
DC bias ON (image area)	1	–	0
DC bias ON (non-image area)*1	1	0	1
DC bias ON (non-image area)*2	1	1	1
DC bias ON (APVC)	0	–	0
DC bias OFF	0	0	1

\*1: Area between sheets

\*2: Cleaning area by transfer / trailing edge area

**Table 4-102 Relationship between DC Bias Output and Signal**

**b. Controlling the DC Bias to a Specific Voltage/Current**

The DC bias applied to the primary charging roller is controlled by the microprocessor (Q900) on the composite power supply PCB so that it remains a specific level.

When a DC bias is generated, the microprocessor (Q900) on the composite power supply PCB detects the DC voltage monitor signal (PDC\_S), compares its level against the reference level, and varies the DC bias control signal (PDC\_PWM) according to the difference so as to ensure that it remains specific level.

**Reference:**

The DC bias control signal varies its pulse duty ratio to change the level of the DC bias.

c. Switching the DC Bias Level

The machine changes the level of its DC bias according to the following: copying image area, sheet-to-sheet distance, and image trailing edge margin. In addition, it is also switched while a cleaning bias is applied by the transfer roller, during which the primary charging roller applies a negative DC bias to prevent the photosensitive drum from being charged to a positive potential.

The level of the DC bias is switched by the DC bias ON signal (serial) from the DC controller PCB. In response to this signal, the microprocessor (Q900) on the composite power supply PCB changes the DC bias control signal (PDC\_PWM) to switch the level of the DC bias applied to the primary charging roller. (See Table 4-102.)

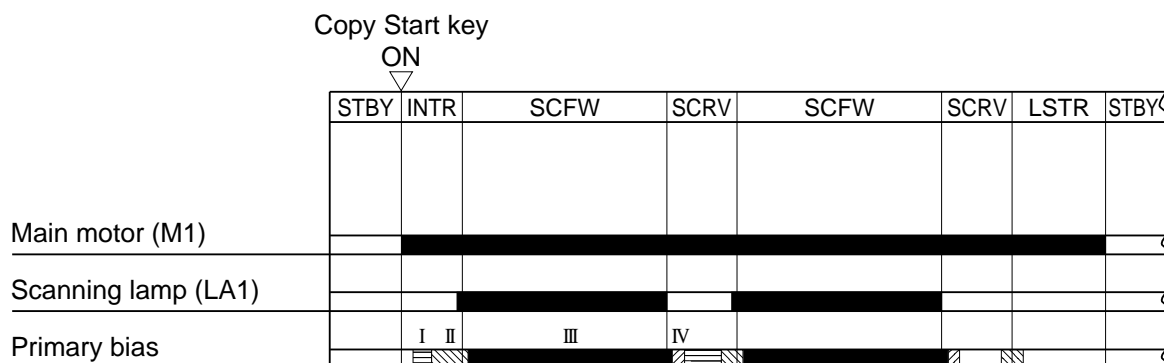

- I: Area between sheets
- II: Cleaning area by transfer
- III: Image area
- IV: Trailing edge area

Figure 4-104

d. Primary Charging Roller Bias Application Voltage Level and Scanning Lamp Activation Voltage Level Automatic Correction Control (APVC, ALVC control)

The quality of copy images can vary in relation to changes in latent static images, which are affected by the following:

- Changes in the sensitivity of the drum
- Changes in the amount of charging of the primary charging roller

These changes occur because of changes in the installation environment (temperature, humidity) or deterioration, wear, and dirt of related parts.

In the machine, these changes tend to increase the light area potential (VL) and the dark area potential (VD).

To correct these changes, the level of voltage applied to the primary charging roller is corrected (APVC control) and, at the same time, the level of the voltage used to turn on the scanning lamp is corrected (ALVC control). These control mechanisms serve to ensure a specific degree of light area potential (VL) and dark area potential (VD) at all times.

The following indicates the timing of auto correction and the flow of operation:

<Timing>

At power-on, During INTR

<Flow>

A voltage of -1376 V is applied to the primary charging roller for about 1.3 sec.



The current at the time is detected by the current detection circuit, and is communicated to the microprocessor (Q900) on the composite power supply PCB.



The microprocessor (Q101) on the DC controller receives the current level from the composite power supply, and determines the voltage used to activate the scanning lamp and the voltage of the primary charging roller bias.\*

- \* The control mechanism uses the return current stored in memory in advance by the DC controller PCB and the correction table for activation voltage/application voltage.

**Caution:**

If you have replaced the composite power supply PCB, be sure to enter the APVC value indicated on the composite power supply PCB using service mode (Nos. 34, 35). Then, be sure to execute 'U7' in user mode (installation/drum replacement mode).

## D. Controlling the Transfer Roller Bias

### 1. Outline

The circuit shown in Figure 4-105 is used to control the voltage applied to the transfer charging roller, and has the following functions:

- Turning on and off the transfer bias.
- Controlling the transfer bias to a constant voltage.
- Correcting the transfer bias voltage level (ATVC)
- Switching the transfer bias polarity (cleaning bias)

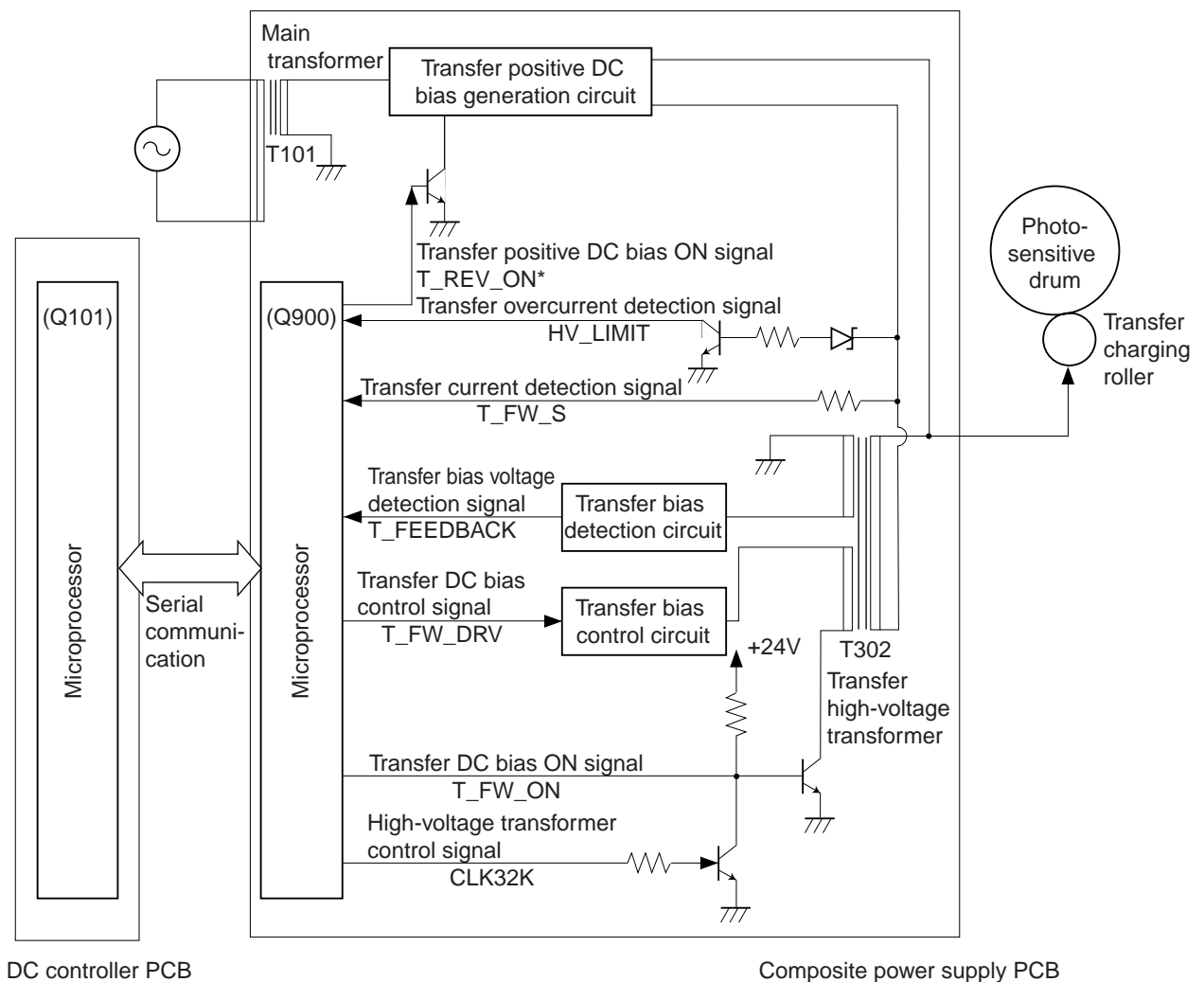

Figure 4-105

**2. Operations**

**a. Turning On and Off the Transfer Bias**

The transfer bias applied to the transfer charging roller is turned on and off by the serial communication signal from the DC controller PCB.

When the transfer bias ON signal (serial signal) is generated by the DC controller PCB, the microprocessor (Q900) on the composite power supply PCB generates the high-voltage transformer control signal (CLK32K), transfer DC bias ON signal (T\_FW\_ON), and transfer DC bias control signal (T\_FW\_DRV), thereby applying the transfer bias to the transfer charging roller.

	Transfer bias ON signal (serial communication)		T-FW_ON signal	T_REV_ON* signal
	bit2	bit3		
Negative transfer bias ON	1	0	1	1
Positive transfer bias ON (cleaning bias)	1	1	1	0
Transfer bias OFF	0	0	0	1
ATVC	0	1	1	1

**Table 4-103 Relationship between Transfer Bias Output and Signals**

**b. Controlling the Transfer Bias to a Specific Voltage**

The transfer bias applied to the transfer charging roller is controlled to a specific level by the microprocessor (Q900) on the composite power supply PCB.

When a transfer bias is generated, the microprocessor (Q900) on the composite power supply PCB checks the transfer bias voltage detection signal (T\_FEEDBACK), compares it against the reference value, and varies the transfer DC bias control signal (T\_FW\_DRV) according to the difference to ensure that the transfer bias remains a specific level at all times.

**Reference:**

The level of transfer bias applied to the transfer roller during a copying run is between -7.5 and -3.0 kV.

c. Correcting the Transfer Bias Voltage Level (ATVC control)

The machine automatically corrects the application voltage level of the transfer bias to correct the changes in the transfer efficiency caused by the deterioration of the transfer roller or the changes in the environment.

A current of a specific level (-14.6  $\mu\text{A}$ ) is applied to the transfer charging roller during initial rotation executed each time the Copy Start key is pressed. The microprocessor (Q900) on the composite power supply PCB checks the transfer current detection signal (T\_FW\_S), and varies the transfer bias applied to the transfer charging roller so that it will be an appropriate level.

Reference:

While the transfer charging roller makes a single rotation, the microprocessor (Q900) checks the transfer current detection signal four times, and determines the level of the transfer bias to apply using the average of the readings.

d. Switching the Polarity of the Transfer Bias (cleaning bias)

The machine uses a direct charging method, allowing toner to move from the photosensitive drum to the transfer roller as when a jam occurs if left unattended.

To remove excess toner, a positive voltage is applied to the transfer roller as follows, thereby returning the toner from the roller to the drum:

<Timing>

- While initial rotation is executed after the Copy Start key is pressed
- Part of the period in which the scanner is moved in reverse
- Part of the period in which last rotation is executed

The polarity of the transfer bias is switched by the transfer bias ON signal (serial signal) generated by the DC controller PCB.

In response to the signal, the microprocessor (Q900) on the composite power supply PCB causes the transfer positive DC bias On signal (T\_REV\_ON\*) to go '0', so that the positive component of the transfer bias (constant current control, +1.56 $\mu\text{A}$  / 2.5kVmax.) will be applied to the transfer roller. (See Table 4-103.)

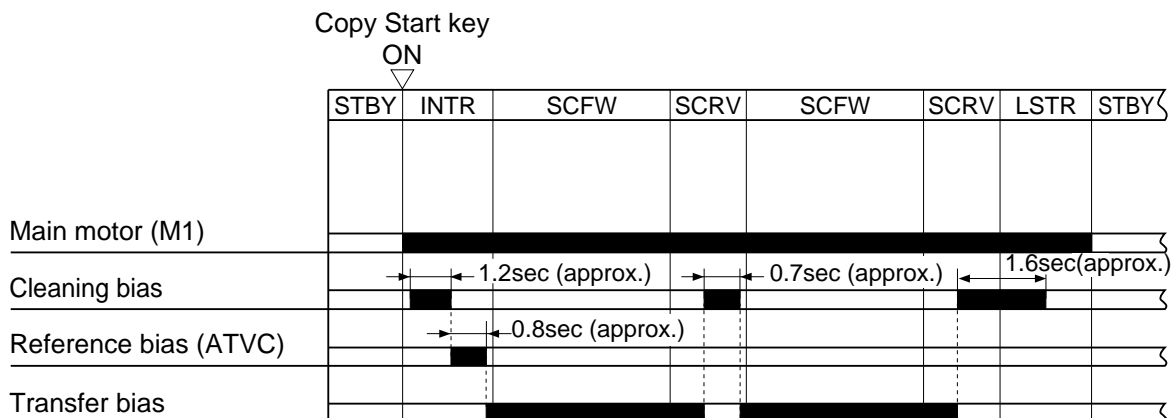

Figure 4-106

## **E. Controlling the Developing/Separation Static Eliminator Bias**

### **1. Outline**

The circuit shown in Figure 4-107 is used to control the voltage applied to the developing assembly and the separation static eliminator, and has the following functions:

- Turning on and off the developing DC bias
- Turning on and off the AC bias (turning on and off the static eliminator bias)
- Controlling the voltage level of the developing DC bias

Both AC bias and DC bias are applied to the developing cylinder while copies are being made. When the photosensitive drum rotates and yet developing is not under way, about -500 VDC is applied to the developing cylinder regardless of the position of the density adjusting lever, thereby preventing adhesion of excess toner on the photosensitive drum.

Reference:

---

Developing DC bias: -40 ~ -550V

Developing AC bias: 1350Vpp±100Vpp

---



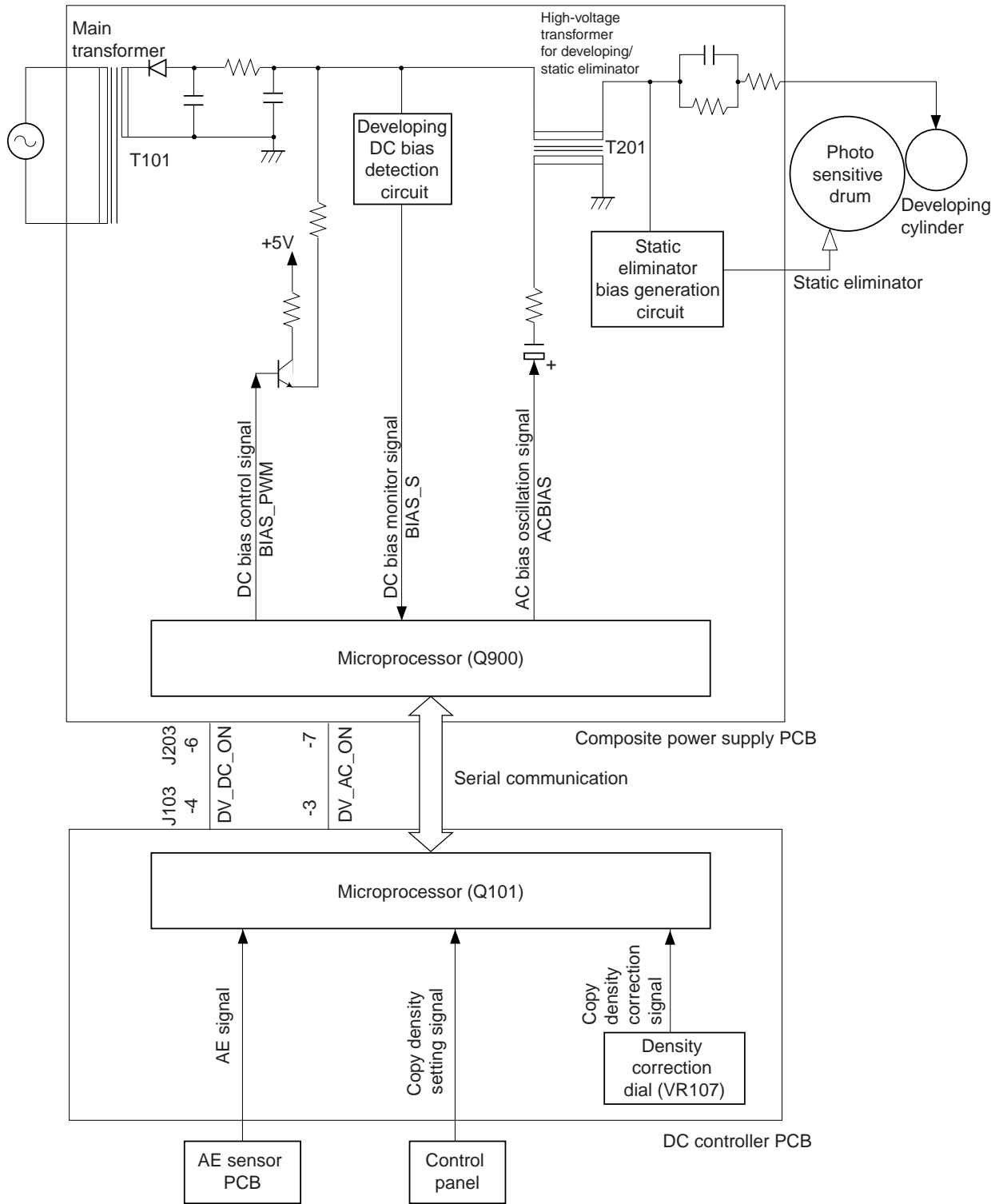

Figure 4-107

## 2. Turning On and Off the DC Bias

The DC bias applied to the developing cylinder is turned on and off by the signal communication signal and the developing DC bias ON signal (DV\_DC\_ON) generated by the DC controller PCB.

When the developing DCON signal (serial signal) and the developing DC bias ON signal (DV\_DC\_ON) are generated by the DC controller PCB, the microprocessor (Q900) on the composite power supply PCB sends the DC bias control signal (BIAS\_PWM), thereby applying a DC bias to the developing cylinder.

	Developing DCON signal (Serial communication)		DV_DC_ON (J103-4)
	bit5	bit6	
DC bias ON	–	1	0
DC bias ON (- 500V)	0	1	1
DC bias OFF	0	0	1

**Table 4-104 Relationship between Developing DC Bias and Signals**

## 3. Turning On and Off the AC Bias

The AC bias is turned on and off by the developing AC bias ON signal (DV\_AC\_ON) generated by the DC controller PCB.

The DC controller PCB sends the developing AC bias ON signal (DV\_AC\_ON) to the composite power supply PCB a specific period of time after copy paper has moved past the registration sensor. The microprocessor (Q900) on the composite power supply PCB generates the AC bias oscillation signal (ACBIAS) so that an AC bias is applied to the developing cylinder.

The AC bias is modified/rectified and then supplied to the static eliminator (static eliminator bias, about 3.2 kV).

#### 4. Developing DC Bias Voltage Level Control

The DC bias control signal (BIAS\_PWM) is varied according to the following settings so as to vary the DC component of the developing bias, thereby controlling the copy density:

- Density lever setting (for manual density adjustment)
- AE sensor output (auto density adjustment)
- Copy mode settings (toner save mode/photo mode)
- Density correction dial (VR107) setting

You can use the density correction dial (VR107) on the DC controller PCB to vary the developing DC bias. Change the bias if copies tend to be foggy or light images because of shifts in the sensitivity of the photosensitive drum. The dial is used when manual density adjustment or auto density adjustment (AE) is executed.

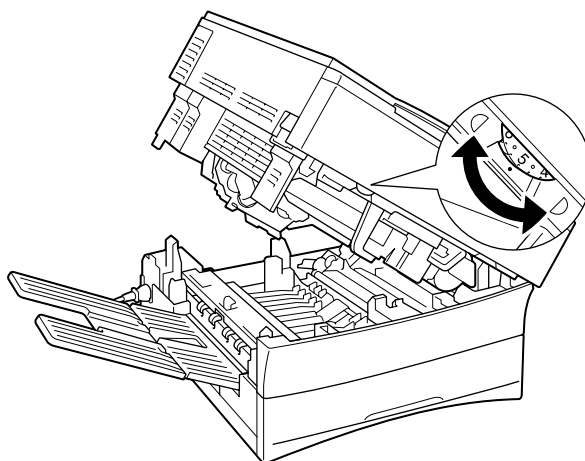

Figure 4-108

The DC controller PCB keeps track of the number of copies made since replacement of the drum unit (drum counter reading, which is initialized when 'U7' in user mode is executed, i.e., installation/drum replacement mode).

To prevent deterioration of copy images, the developing DC bias, voltage supplied to the scanning lamp, and primary charging DC bias are corrected as follows when the drum counter reading exceeds '20000'.

	Normal mode		Toner save mode		Photo mode	
	I	II	I	II	I	II
Developing bias	+15V	-30V	-5V	-50V	+85V	+85V
Lamp supply voltage	---	+3.2V* <sup>1</sup> (+5.7V* <sup>2</sup> )	-2.7V* <sup>1</sup> (-4.7V* <sup>2</sup> )	+1.2V* <sup>1</sup> (+2.2V* <sup>2</sup> )	-2.7V* <sup>1</sup> (-4.7V* <sup>2</sup> )	-2.7V* <sup>1</sup> (-4.7V* <sup>2</sup> )
Primary DC bias	+32V	-80V	+112V	-----	+112V	+112V

\* The DC bias value in the table is a correction value based on the value in Figure 4-109 and 4-110.

**Table 4-105 Relationship between Copying Mode and Correction Value**

I: If the drum counter reading is lower than '20000'.

II: If the drum counter reading is '20000' or higher.

\*1: 120V type.

\*2: 220/240V type.

**Related Service Mode**

60	Counter for the drum unit currently in use
61	Counter for the most recent drum unit
62	Counter for the second most recent drum unit

Figures 4-109 and 4-110 show the changes in the DC bias caused by changes in the output of the AE sensor during auto density adjustment and the density adjusting lever settings during manual adjustment.

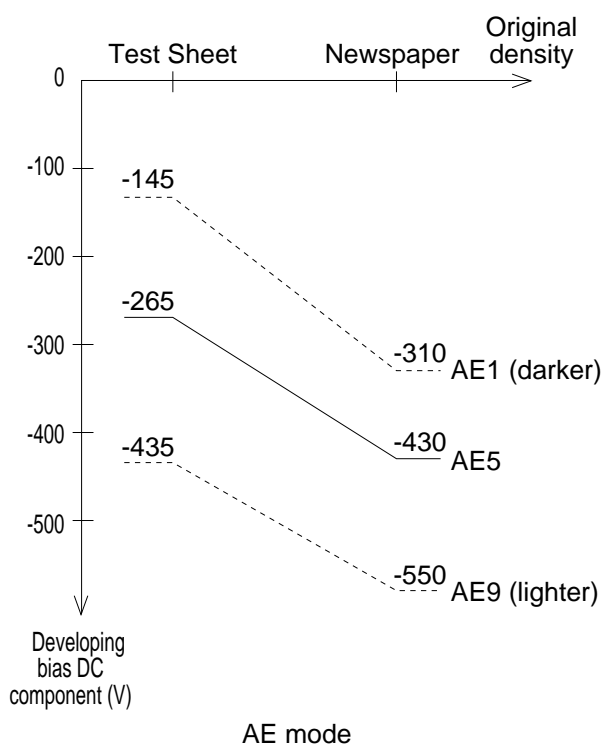

Figure 4-109

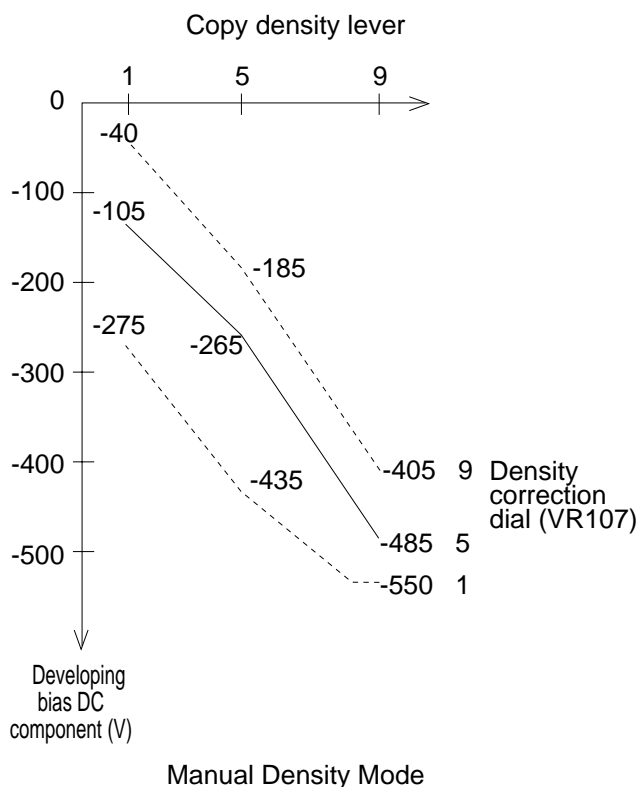

Figure 4-110

## F. Measuring the Density of Originals

### 1. Outline

The machine is equipped with an auto density adjustment (AE) mechanism designed to control the DC component of the developing bias.

The AE mechanism enables production of copies free of fogging as long as the original is more or less uniform in density by varying the DC component of the developing bias according to the density of the original.

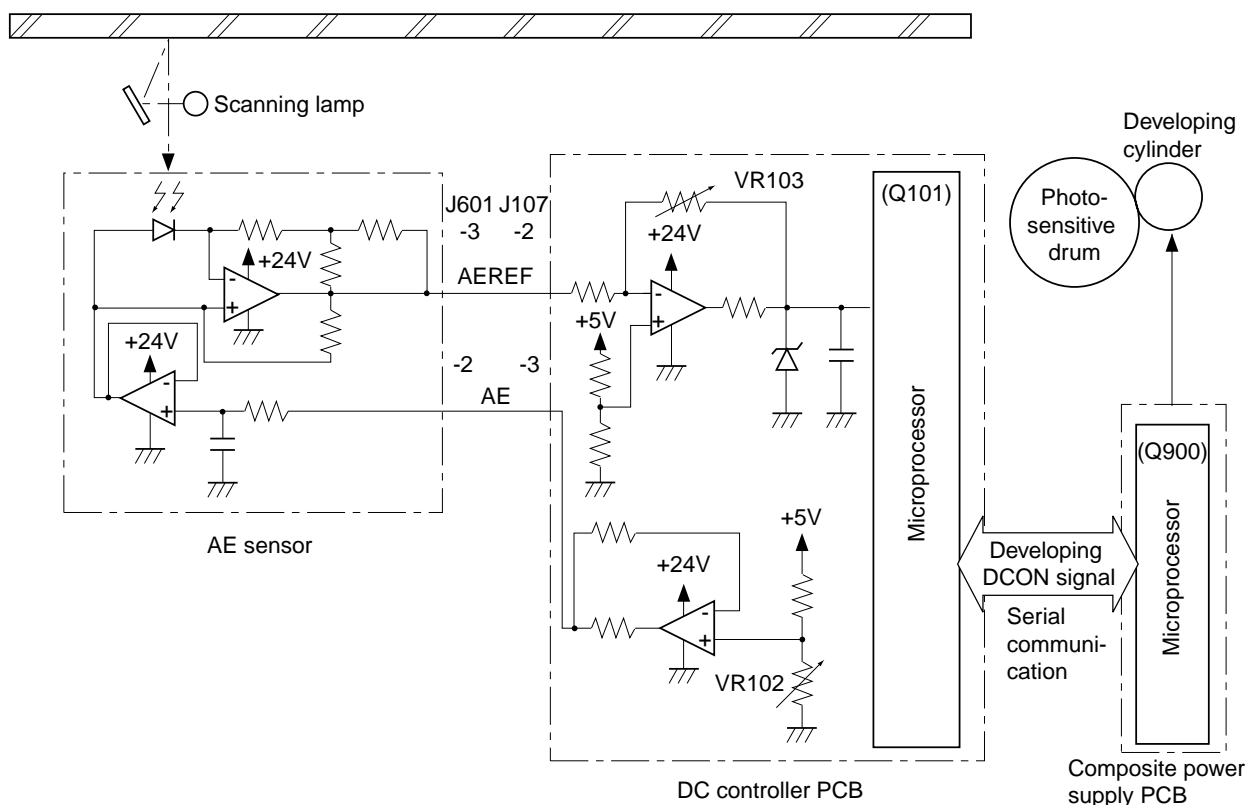

Figure 4-111

## 2. Operations

When measuring the density of an original, the scanner turns on the scanning lamp, and moves to a point 115 mm from the home position. At this time, the AE sensor reads the level of light reflected by the area shown in Figure 4-112, and sends the AE signal (AE) to the DC controller PCB.

In response, the DC controller PCB sends the developing DCON signal (serial communication) to the composite power supply PCB according to the level of the AE signal. The microprocessor (Q900) on the composite power supply PCB controls the level of the DC bias applied to the developing cylinder based on the level of this signal.

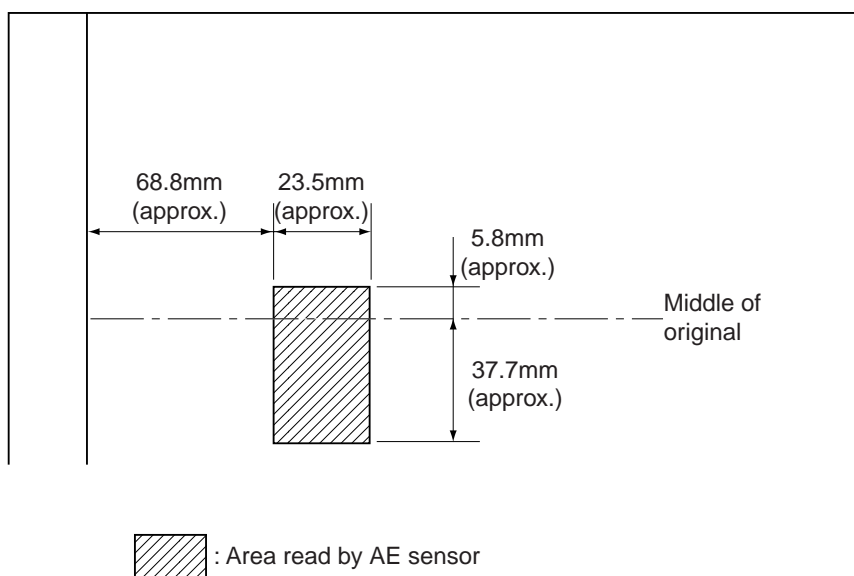

Figure 4-112

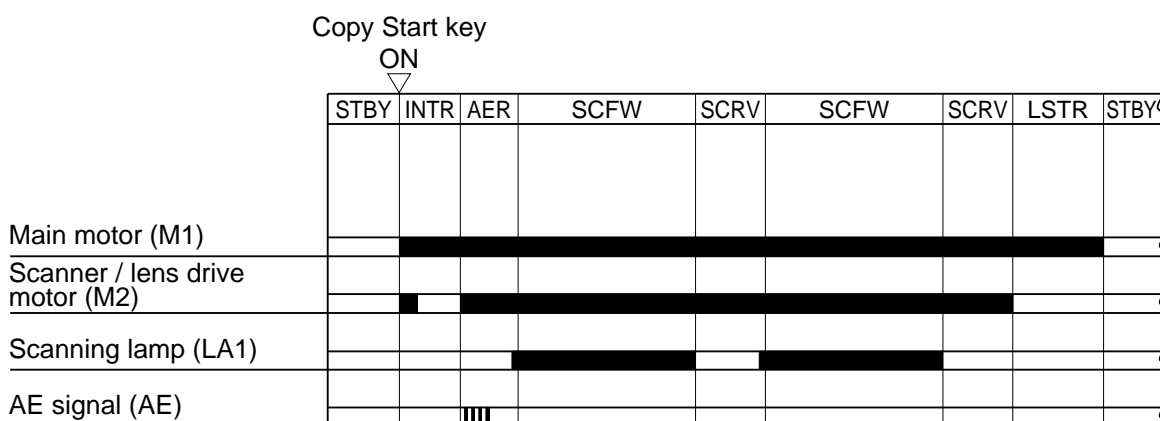

Figure 4-113

### 3. AE Adjustment (VR102, VR103)

If you have replaced the scanning lamp or the AE sensor PCB, be sure to make the following adjustments:

#### Making Adjustments

##### Before the Work

- Obtain a newspaper more or less even in density. (Avoid ones with photos or large characters.)
  - Obtain five sheets of white sheets of paper
  - Check to make sure that the intensity of the scanning lamp has been adjusted properly when you have replaced the scanning lamp.
  - Set the density correction dial (VR107) to the middle setting.
- 1) Open the top unit; then, remove the two screws [1], and detach the front upper cover [2].

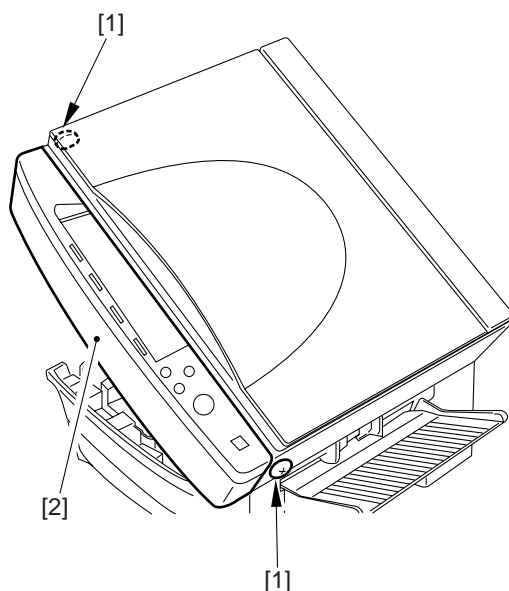

Figure 4-114

#### Caution:

The flexible cable for the control panel is connected to the upper front cover; disconnect the cable from the DC controller PCB.



- 2) Close the top unit, and connect the flexible cable from the control panel to the DC controller PCB; then, turn on the power switch.
- 3) Check to make sure that AE mode has been enabled, and short JP103 and JP104 on the DC control PCB with a screwdriver or the like.
  - The display will indicate 'F'.

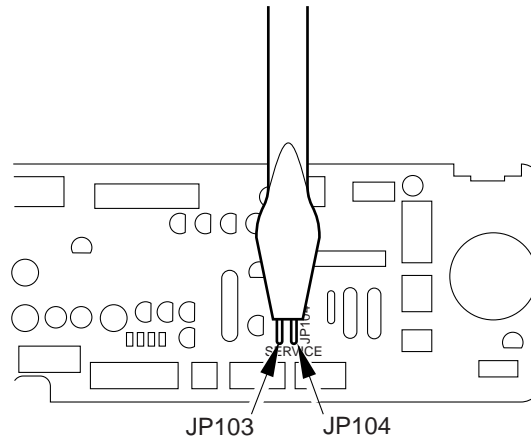

Figure 4-115

- 4) While the display is indicating 'F', stop shorting JP103 and JP104.
- 5) Select '40' in service mode.
  - The display will indicate '40'.
- 6) Press the Copy Start key.
  - The scanner will move forward, and the scanning lamp will turn on.
- 7) Turn VR103 on the DC controller PCB fully clockwise.

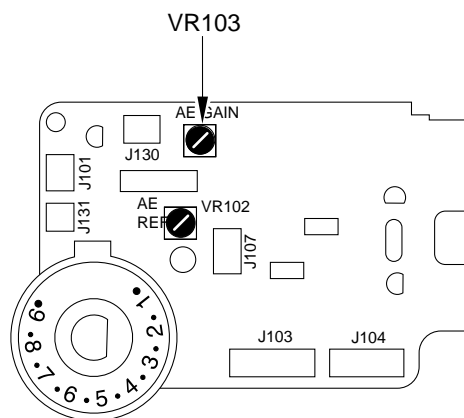

Figure 4-116

- 8) Place a newspaper on the copyboard, and close the copyboard cover.
- 9) Turn VR102 so that the display indicates 'A3' through 'Ad'.

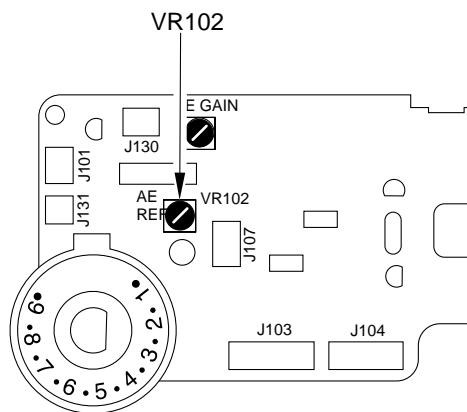

Figure 4-117

- 10) Remove the newspaper from the copyboard, and place five sheets of copy paper on the copyboard glass in its place; then, close the copyboard cover.
- 11) Turn VR103 on the DC controller PCB so that the display on the control panel indicates '52' through '5c'.

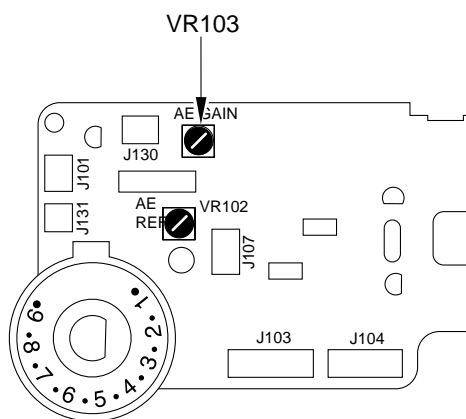

Figure 4-118

12) Repeat steps 8) through 11) so that the values of both VR102 and VR103 are target values.

**Caution:**

If you cannot set VR102 and VR103 to the target values at the same time, turn VR103 fully counterclockwise, and go back to step 8) and make adjustments once again.

13) Make a copy, and check to make sure that it is free of fogging and the characters are dark enough.

- If the copy is foggy or its characters are not dark enough, go back to step 1) and start over.
- If the results are still not good after adjustment for a second time, use the density correction dial (VR107).

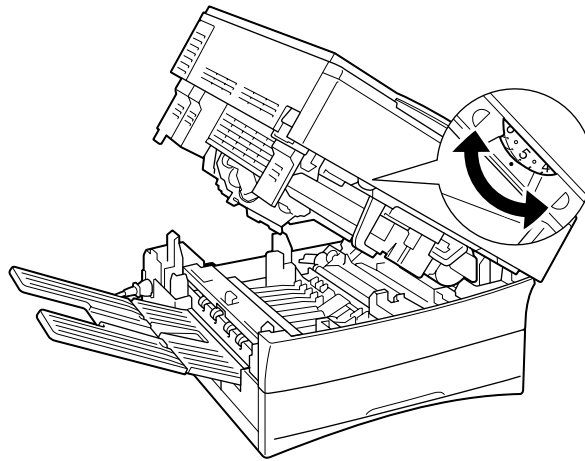

**Figure 4-119**

## G. Controlling the Pre-Exposure Lamp

### 1. Outline

The machine is equipped with a pre-exposure lamp to ensure stable generation of images by removing residual charge from the photosensitive drum.

### 2. Operations

#### a. Controlling the Intensity of the Pre-Exposure Lamp

The intensity of the pre-exposure lamp is controlled based on the settings of '33' (IP\_OFST) and '37' (PREX\_LP) made in service mode.

The microprocessor (Q101) on the DC controller PCB controls the pre-exposure lamp control signal (PEXP\*) according to the levels of IP\_OFST and PREX\_LP so as to vary the voltage supplied to the pre-exposure lamp.

#### Related Service Mode

33 (IP_OFST)	Corrects the current used during APVC measurement.
37 (PREX_LP)	Adjusts the intensity of the pre-exposure lamp.

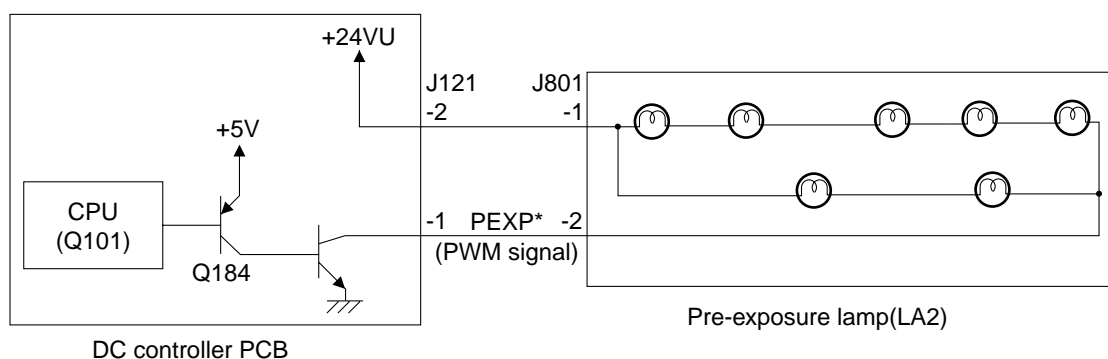

Figure 4-120

#### Reference:

The levels of PREX\_LP and IP\_OFST are adjusted and stored at the factory. If you have replaced the pre-exposure lamp or the drum unit, be sure to enter the values recorded on the label attached to each part.

b. Changing the Intensity

The machine changes the intensity of the pre-exposure lamp between image areas and non-image areas.

Except for APVC measurement and non-image areas, the voltage used to turn on the pre-exposure lamp is dropped to prevent overheating inside the machine.

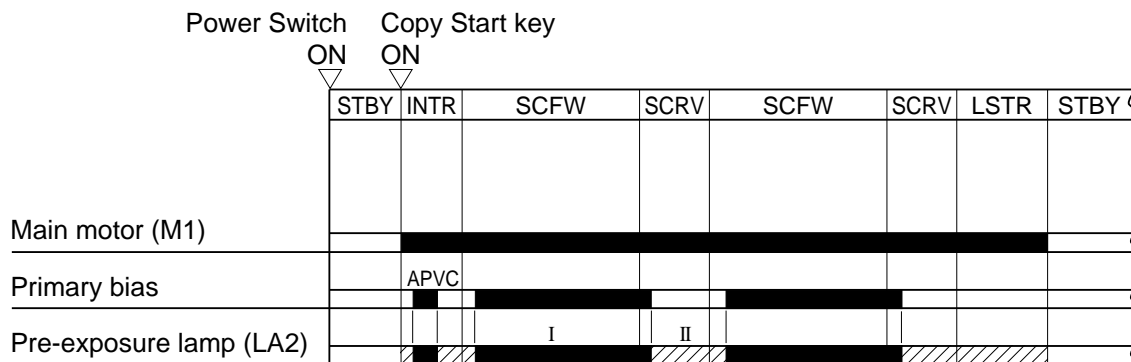

- I: Image area
- II: Non-image area

Figure 4-121

## H. Controlling the Side Blanking Mechanism

### 1. Outline

The machine is equipped with a side blanking lamp at the front and the rear used to prevent adhesion of excess toner when making reduced copies.

### 2. Operations

To blank out the non-image area in reduce mode, the side blanking lamp is moved in relation to the distance over which the lens moves as detected by the lens shift detecting shaft.

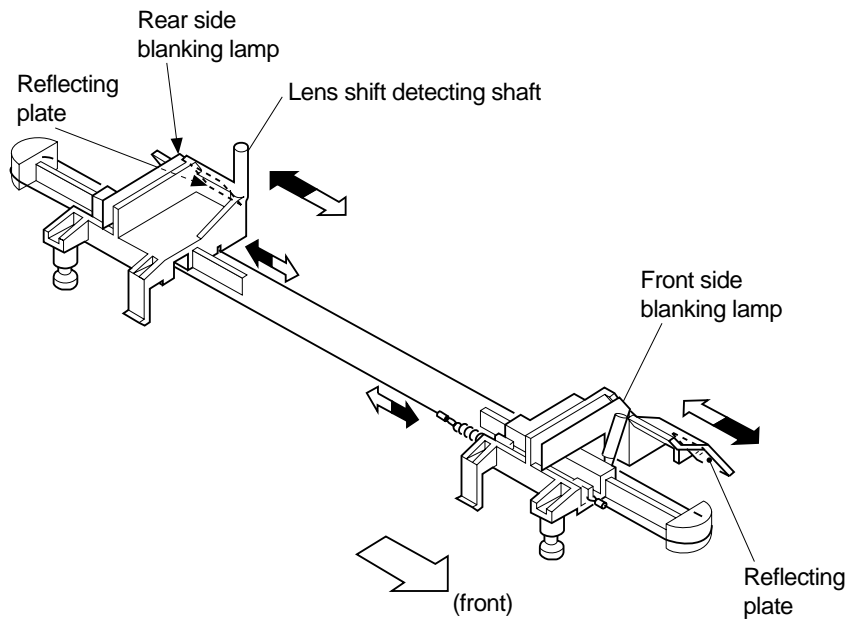
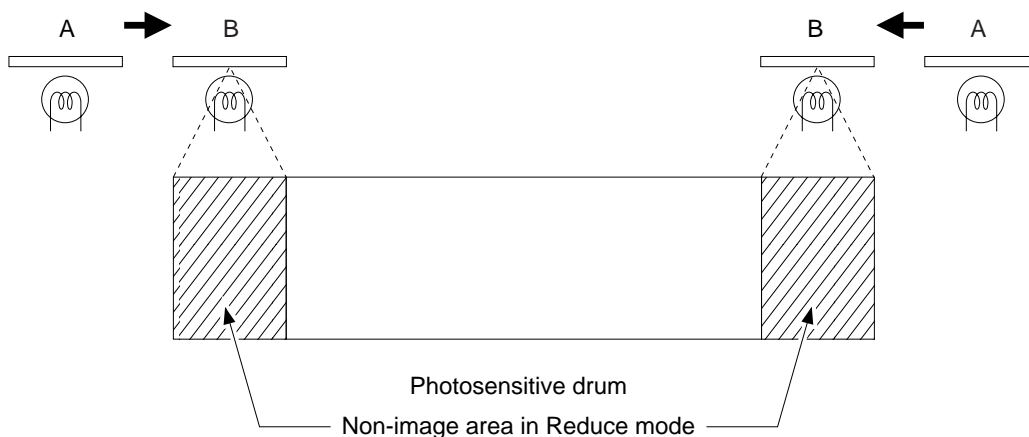

Figure 4-122



A: Position of the side blanking lamp in Direct and Reduce mode  
 B: Position of the side blanking lamp in Reduce mode

Figure 4-123

## II. DEVELOPING ASSEMBLY/CLEANING ASSEMBLY

### A. Outline

The machine's developing assembly may be locked into or out of position by means of a locking lever.

The developing cylinder inside the developing assembly and the waste toner feeding blade of the drum unit are rotated by the drive of the main motor (M1).

The level of toner inside the developing assembly is monitored by the toner level antenna; when the level drops below a specific value, the Replace Toner Cartridge message will start to flash on the control panel.

The waste toner collected by the cleaning blade is held inside the drum unit, and is sent to the rear of the drum unit by the toner feed blade.

The primary charging roller is cleaned by the cleaning pad operated by the cleaning solenoid (SL6).

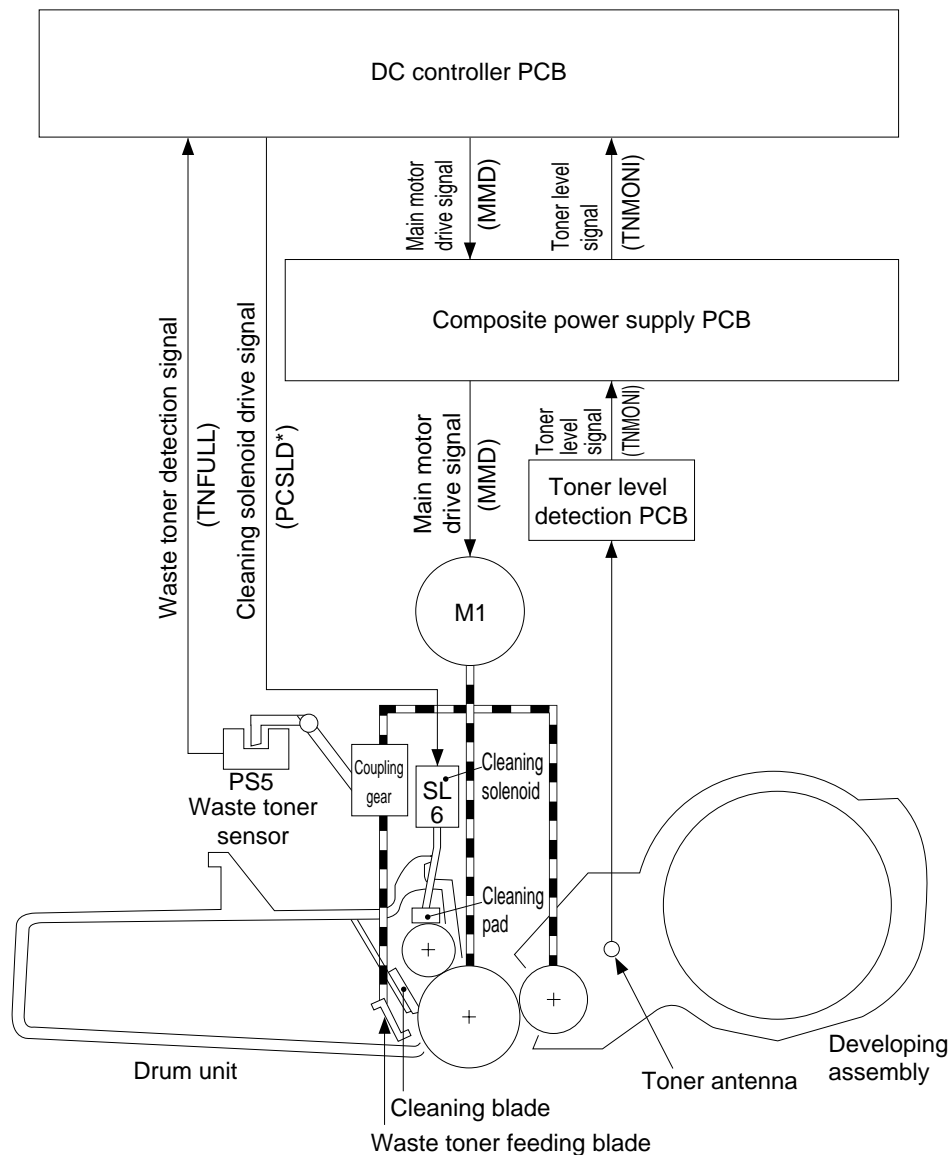

Figure 4-201

## B. Detecting the Level of Toner

### 1. Outline

The level of toner inside the developing assembly is monitored by the toner level antenna and the toner level detection circuit.

The toner level antenna is mounted inside the developing assembly, and an AC bias is applied to the developing cylinder.

The developing cylinder and the antenna are statically bonded, and the level of toner is detected with reference to the changes in the degree of the bond.

### 2. Operation

The amount of static between the developing cylinder and the toner level antenna changes according to the level of toner inside the developing assembly. The AC bias occurring in relation to the level of toner inside the developing assembly is checked by the toner level antenna, and the result is sent to the toner level detection circuit. An AC bias of the same level as the bias applied to the developing cylinder is also sent to the toner level detection circuit as a reference signal.

The toner level detection circuit compares the signal (AC bias level) from the toner level antenna against the reference signal to find out the level of toner.

In the absence of toner, the level of the signal from the toner level antenna will be lower than that of the reference signal.

During copying operation, the DC controller PCB checks the toner signal every 0.25 msec, treating data collected of 100 checks (equivalent of one A4 copy) as a single block. If it finds that the data indicating levels suggesting the absence of toner is 90% or more, it will identify the block in question as indicating the absence of toner.

If six such blocks occur in succession, the absence of toner will be identified, and the Replace Toner Cartridge message will be flashed on the control panel.

The toner signal detected during copying operation is stored in memory on the DC controller PCB, and the data will be retained for accumulation even when the power switch is turned off and on.

All copying operations are prohibited while the Replace Toner Cartridge message is flashed. If the absence of toner is detected during a continuous copying job, the ongoing operation will be stopped when as many as five copies have been made after the detection of the absence of toner.

The Replace Toner Cartridge message will go out when the power switch is turned off and then on, enabling copying operation once again. The level of toner is checked during last rotation executed after copying operation once; if the absence of toner is detected, the message will be flashed once again.

As many as 100 copies may be made after the detection of the absence of toner; however, subsequent copying will be prohibited unless toner has been replenished.

If the cumulative number of copies reaches 100 during a continuous copying job, copying will be stopped thereafter.



Reference:

When you are turning on the power switch after making 100 copies following the detection of the absence of toner, execute toner stirring mode (about 1 min max.) to find out whether toner has been replenished.

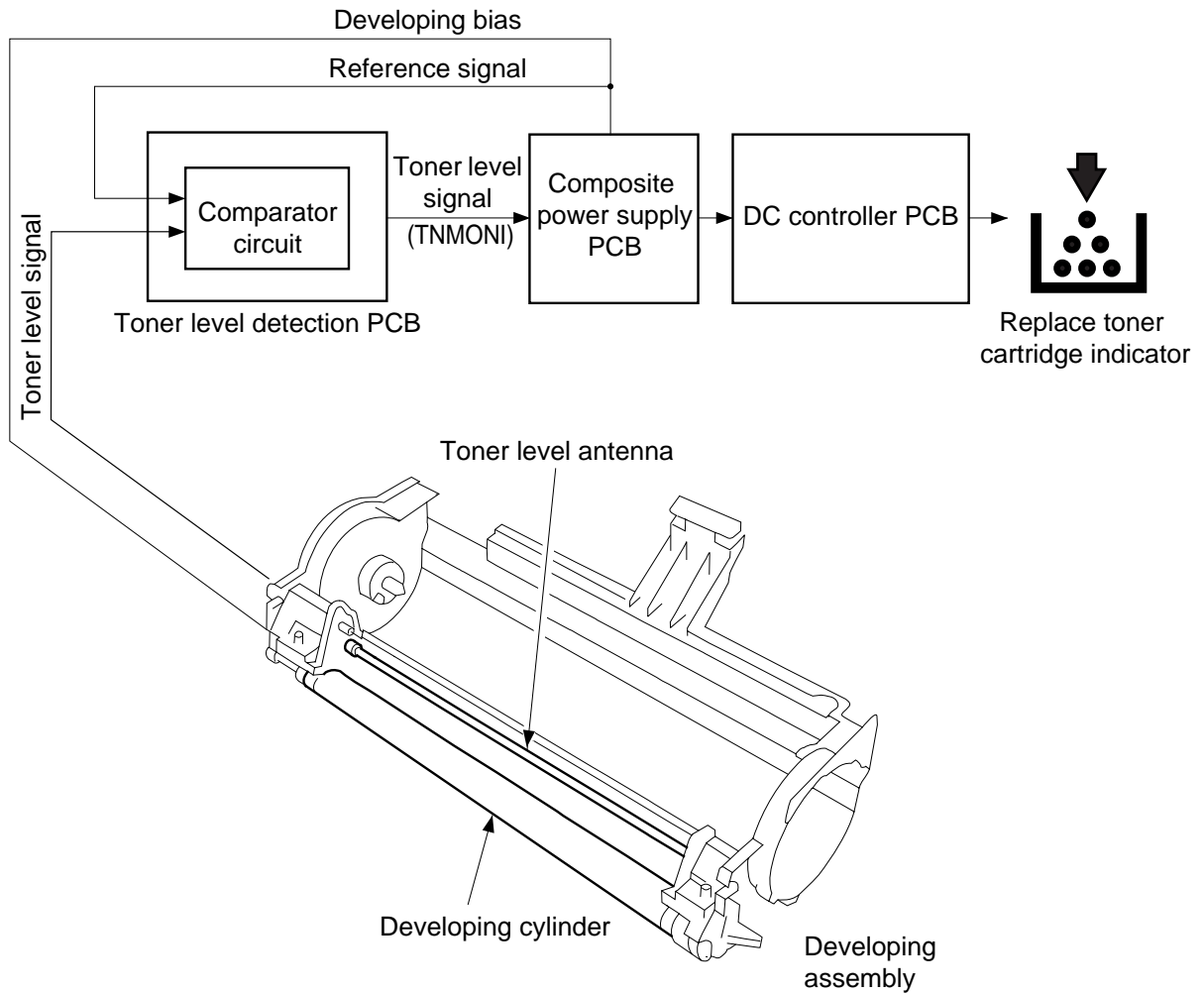

Figure 4-202

### C. Detecting Waste Toner

The drive occurring as the result of rotation of the photosensitive drum is transmitted to the drum gear, coupling gear, and waste toner feed blade drive gear in sequence. The waste toner collected by the cleaning blade is sent to the rear of the inside of the drum unit.

The coupling gear is forced against the drum gear and the waste toner feed blade by means of a spring, and serves to transmit the drive from the main motor to the toner feed blade drive gear through the drum gear.

When the inside of the drum unit becomes full of waste toner and, as a result, the rotation of the waste toner feed blade starts to drag, the engagement of the waste toner feed blade drive gear and the coupling gear breaks, moving the detecting lever of the waste toner sensor (PS5). This condition will cause the DC controller PCB to find out that the drum unit is full of waste toner, consequently flashing the Replace Drum Unit message on the control panel.

Copying operation will still be possible even while the Replace the Drum Unit message is flashing. The DC controller PCB does not retain the memory of the level of waste toner, and the message will not come back when the power has been turned off and then on again.

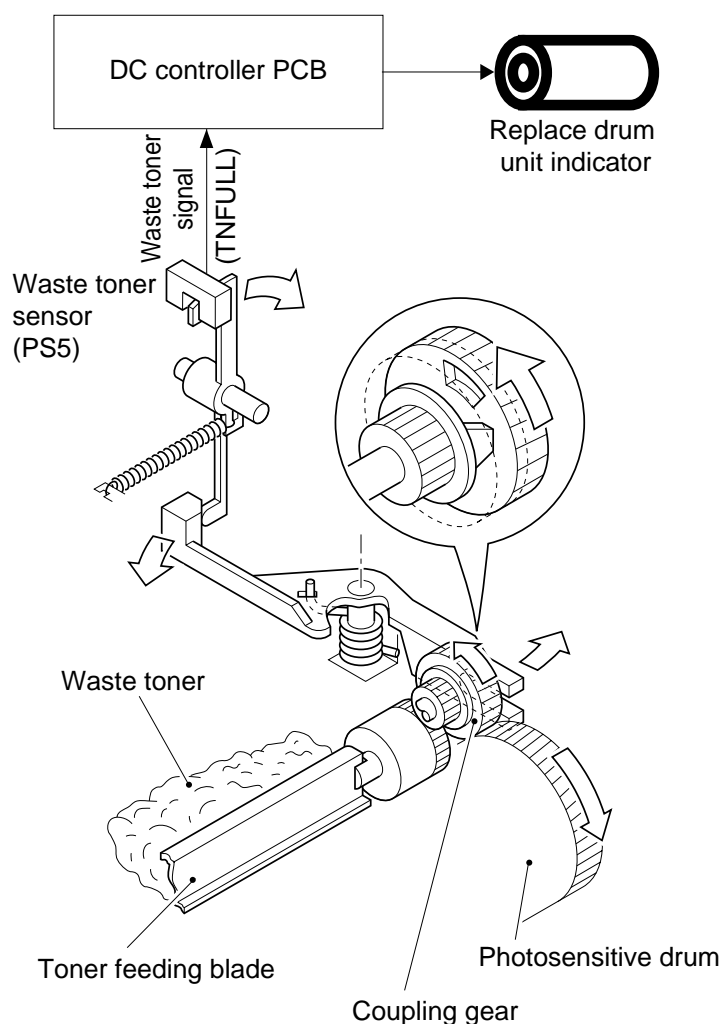

Figure 4-203

## D. Primary Charging Roller Cleaning Control

### 1. Outline

The machine is equipped with an automatic cleaning mechanism used to remove toner and paper lint sticking to the primary charging roller.

### 2. Operations

The primary charging roller is cleaned by turning on the primary charging roller cleaning solenoid (SL6), thereby forcing the cleaning pad against the roller.

The cleaning pad is forced against the roller for about 1.5 sec. While the roller is being cleaned, all other high-voltage outputs are turned off except the developing DC bias (cleaning bias).

Cleaning is executed for the following three independent conditions:

- Condition 1

During last rotation after making 10 copies (cumulative).

For this condition, cleaning is executed only once between when the power is turned on and when it is turned off. The number of copies made after these ten will be stored in memory by the DC controller PCB and added to the number of copies made after the power is turned on next time.

- Condition 2

During last rotation after making 20 copies (cumulative).

For this condition, there is no limit to the number of times cleaning is executed, and the cumulative number is cleared when the power is turned off and then on.

- Condition 3

When user mode 'U1' has been executed.

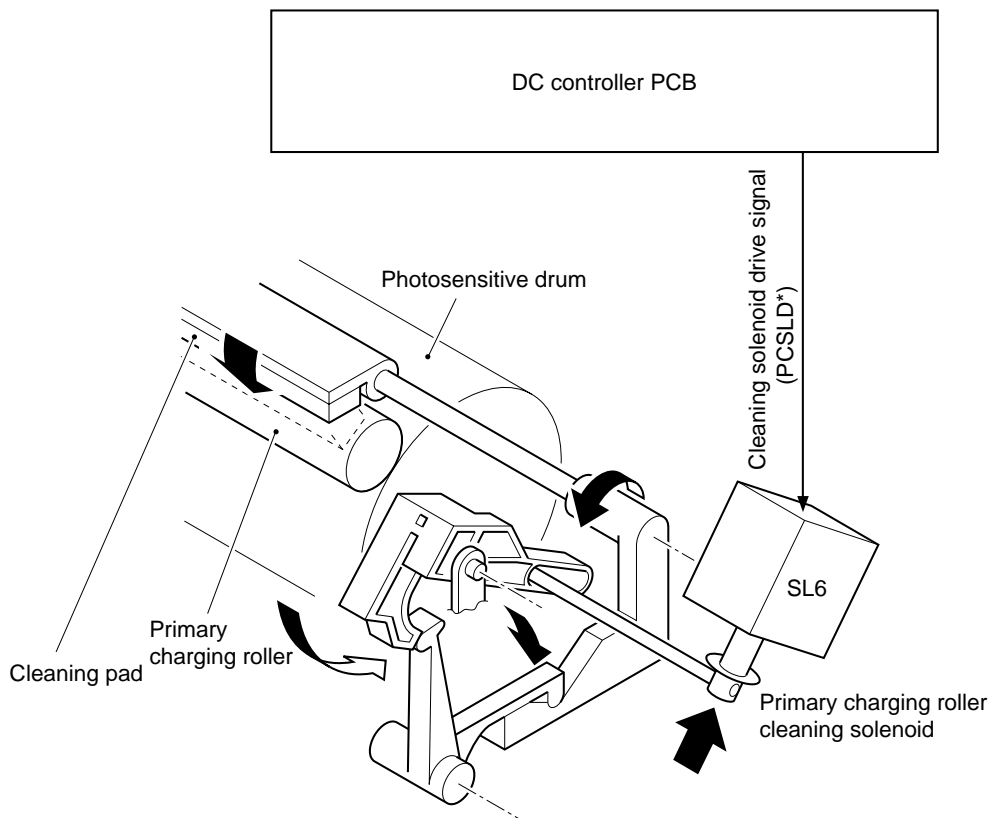

Figure 4-204

### 3. Timing of Cleaning

• Condition 1

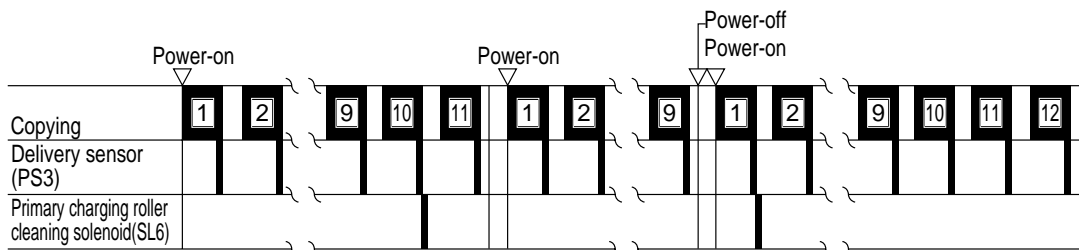

Figure 4-205

• Condition 2

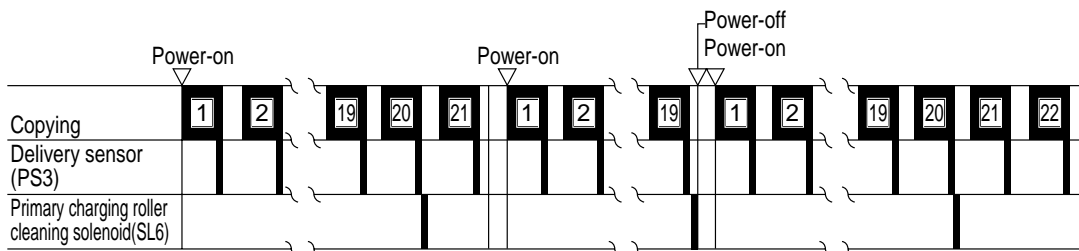

Figure 4-206

### III. DISASSEMBLY/ASSEMBLY

As needed, disassemble/assemble the machine with the following in mind:

1. **▲** Before starting the work, turn off the power switch and disconnect the power plug for safety.
2. Unless otherwise instructed, assemble the parts by reversing the steps used to disassemble it.
3. Identify the screws by type (length, diameter) and location.
4. Use the washers where necessary. (The screws used to mount the grounding wire and Varistors come with a washer to ensure electrical continuity.)
5. As necessary, cut the harness band.
6. As a rule, do not operate the machine with any of its part removed.
7. A few of the screws used are special screws (with wider thread intervals). Do not use any screws indiscriminately.

## A. Drum Unit

### 1. Outline

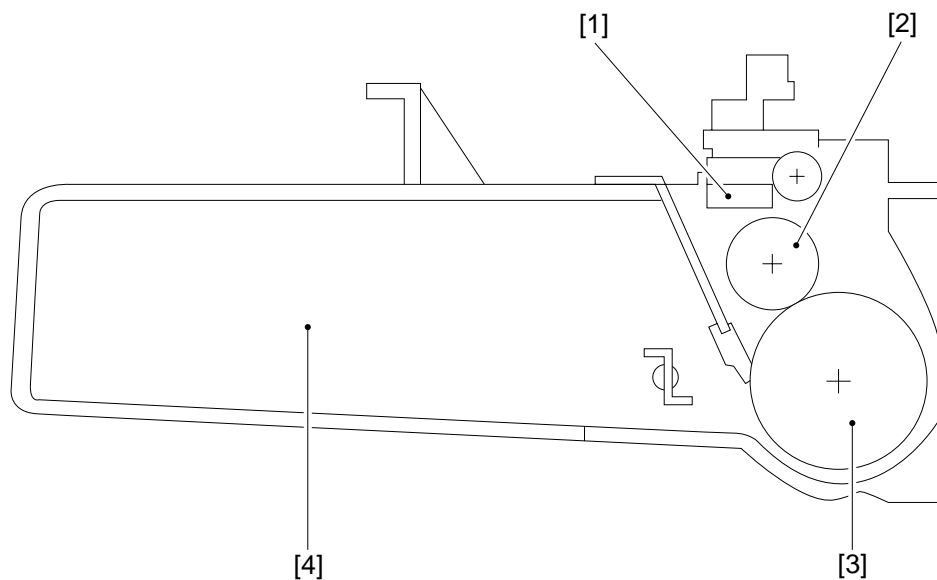

Figure 4-301

- [1] Primary charging roller cleaning pad
- [2] Primary charging roller
- [3] Photosensitive drum
- [4] Drum cleaner assembly

## 2. Removing the Drum Unit

- 1) Open the machine's top unit.
- 2) Turn the developing locking lever [1] counterclockwise.

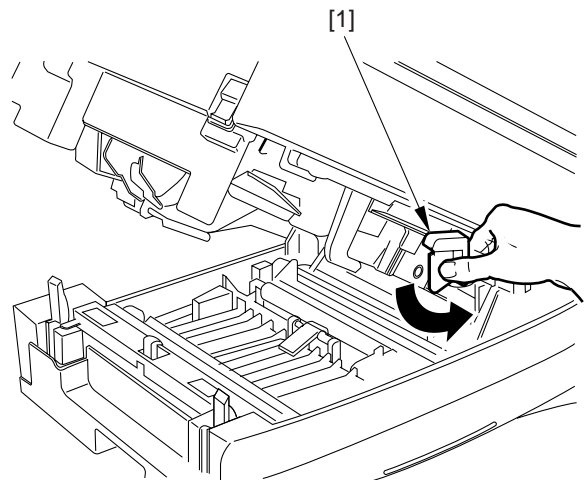

Figure 4-302

- 3) Turn the fixing lever [2] of the drum unit counterclockwise.

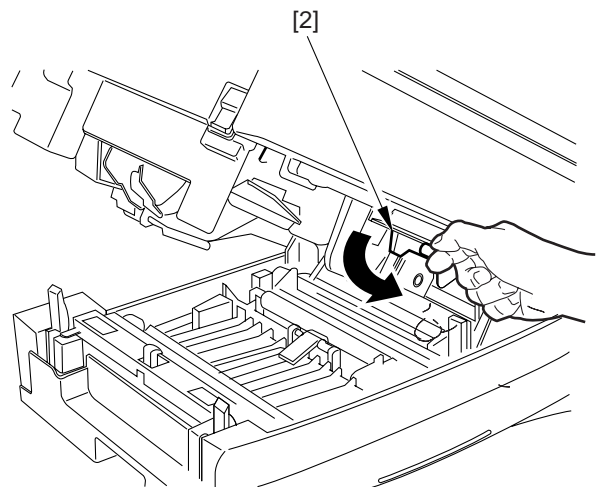

Figure 4-303

- 4) Pull out the drum unit [3] slowly to the front.

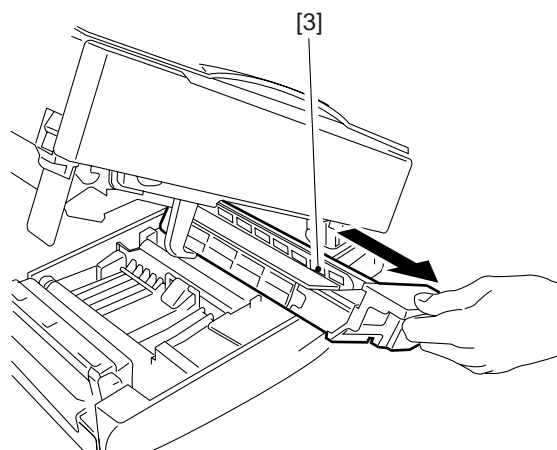

Figure 4-304

**Caution:**

1. Take care not to damage the photosensitive drum.
2. The photosensitive drum is highly susceptible to light. Exposure even to room light can lead to white spots or black bands on the copies.
3. Do not make a copy without the drum unit installed. Otherwise, excess loads can cause the gears of the drive system to skip teeth, generating abnormal noise.

**3. Cleaning**

If the surface of the photosensitive drum is soiled, wipe it with a flannel cloth coated with toner. (Do not use paper, lint-free or otherwise.)

**Caution:**

- Do not dry wipe the drum or do not use a solvent.
- Do not use drum cleaning powder.



**4. After Replacing the Drum Unit**

- 1) Record the date and the counter reading in the label [1] shown in the figure, and attach the label to the front cover of the new drum unit.

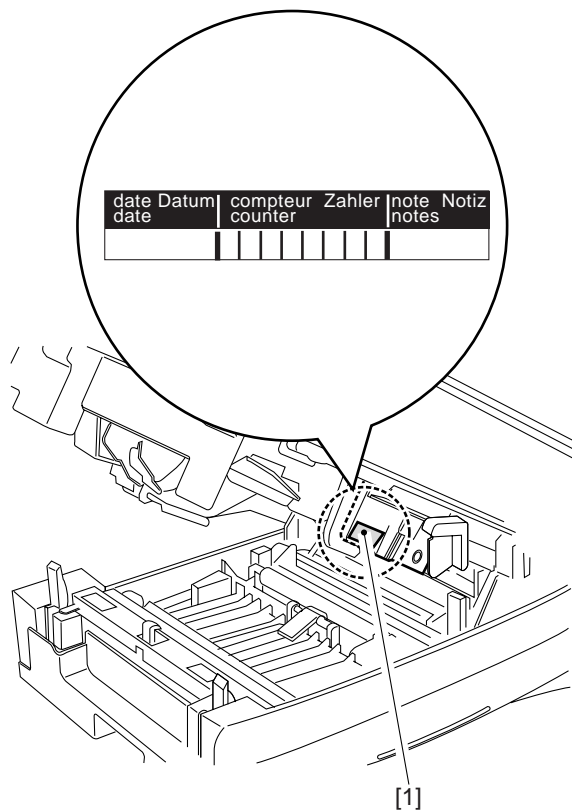

**Figure 4-305**

- 2) Execute 'U7', 'installation/drum unit replacement mode', and enter the setting recorded on the service label attached to the drum unit.

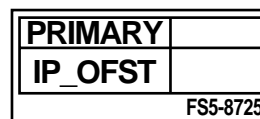

**Figure 4-306**

## B. Transfer Charging Assembly

### 1. Removing the Transfer Charging Roller

- 1) Open the machine's top unit.
- 2) Remove the screw [1].
- 3) While freeing the claw [2] of the bushing, detach the transfer charging roller [3].

**Caution:**

Do not touch the surface of the roller. Be sure the surface is free of dirt.

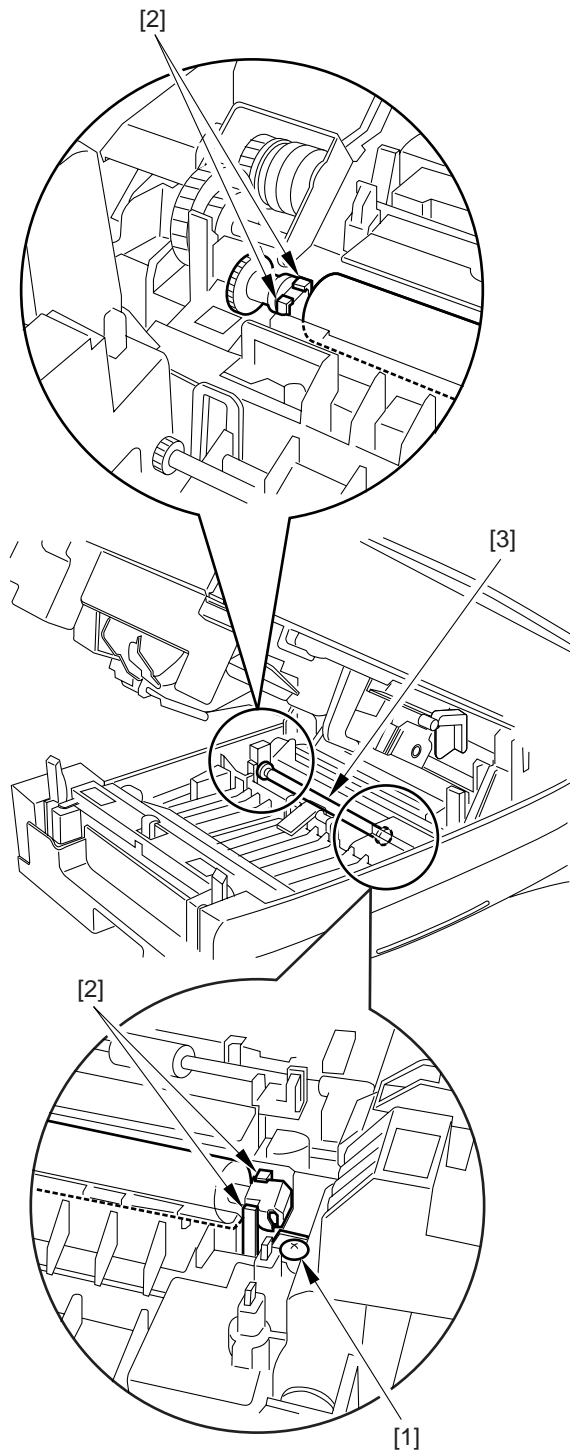

Figure 4-307

## C. Blank Exposure

### 1. Removing the Blanking Exposure Unit

- 1) Set the machine to the maximum ratio (141%) as follows:
  - Turn on the power, and select a default ratio of 141%.
  - Press the Copy Start key.
  - When the lens has moved to the farthest left, turn off the power.
  - Disconnect the power plug.
- 2) Remove the front lower cover.  
(See Chapter 7.III.A.2. "Removing the Front Lower Cover.")
- 3) Remove the drum unit.  
(See A.2. "Removing the Drum unit.")
- 4) Remove the DC controller PCB.  
(See Chapter 7.III.E.1. "Removing the DC controller PCB.")
- 5) Remove the composite power supply PCB.  
(See Chapter 7.III.E.2. "Removing the Composite Power Supply PCB.")
- 6) Remove the two screws [1].

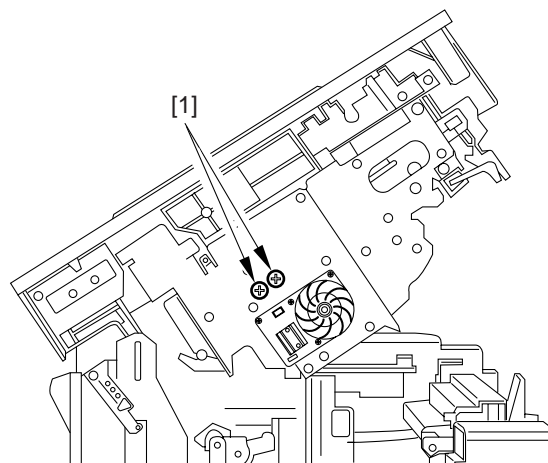

Figure 4-308

- 7) Remove the developing assembly.  
(See D.2. "Removing the Developing Assembly.")

- 8) Open the machine's top unit farther, and hold it in place with the handle of a screwdriver (about 30 mm in diameter).

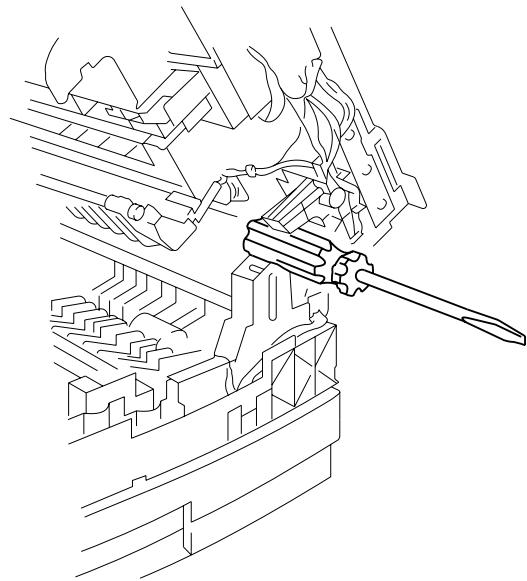

Figure 4-309

- 9) Remove the four screws [3], and disconnect the connector [4]; then, detach the blanking exposure unit. [5].

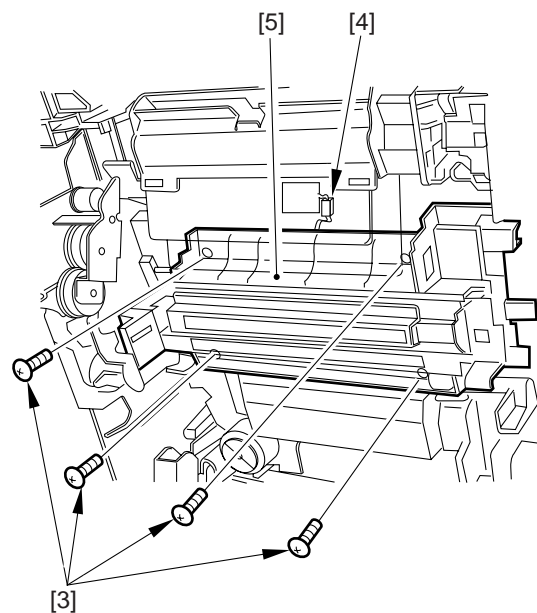

Figure 4-310

**Caution:**

When mounting the blanking exposure unit, check to make sure that the blanking exposure unit PCBs are at the extreme ends and that the lens is positioned at the farthest left (141% position).

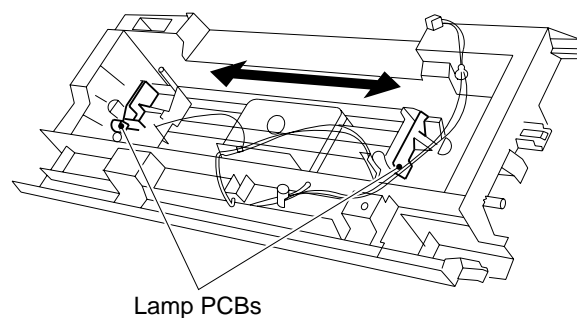

Figure 4-311

## 2. Removing the Pre-Exposure Lamp PCB Unit

- 1) Remove the drum unit.  
(See A.2. "Removing the Drum unit.")
- 2) Disengage the two claws [1], and remove the pre-exposure lamp unit [2].

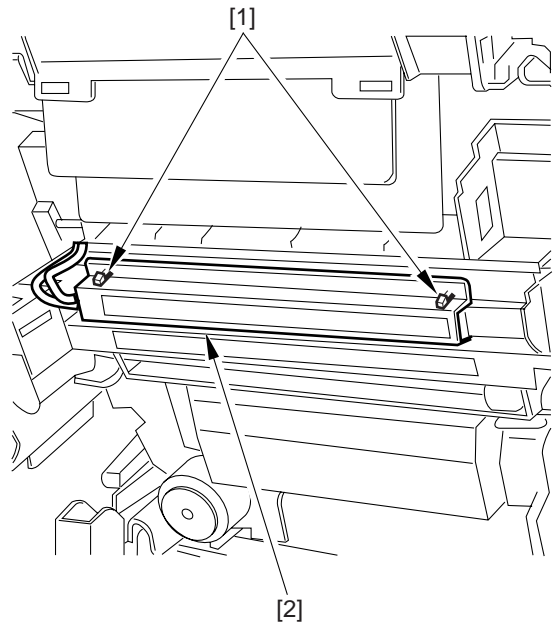

Figure 4-312

- 3) Remove the screw [3], and remove the pre-exposure lamp unit cover [4].

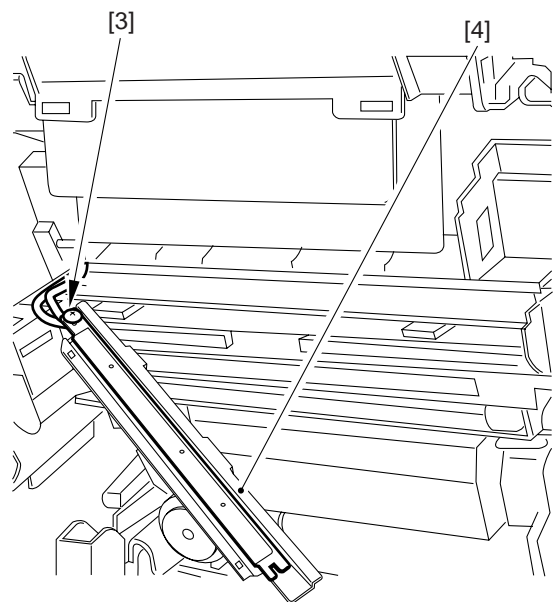

Figure 4-313

- 4) Disconnect the connector [5] (J801), and remove the pre-exposure lamp PCB unit [6].

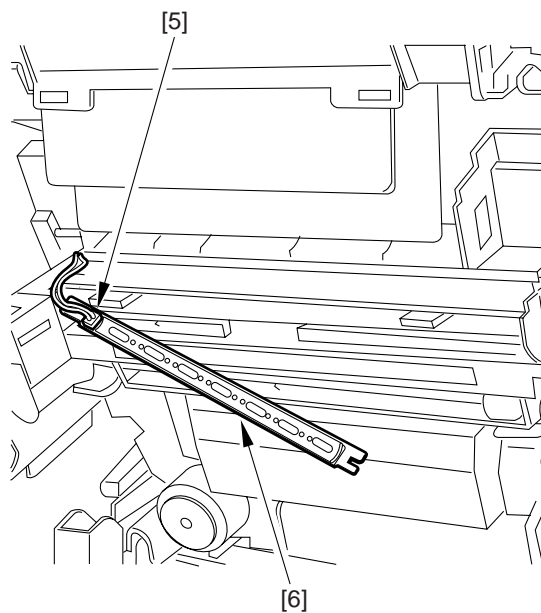

Figure 4-314

**Caution:**

Perform the following whenever you have replaced the pre-exposure lamp PCB unit.

- 1) Enter the setting recorded on the service label attached on the back of the PCB using '37' of service mode.

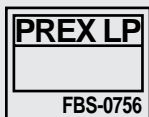
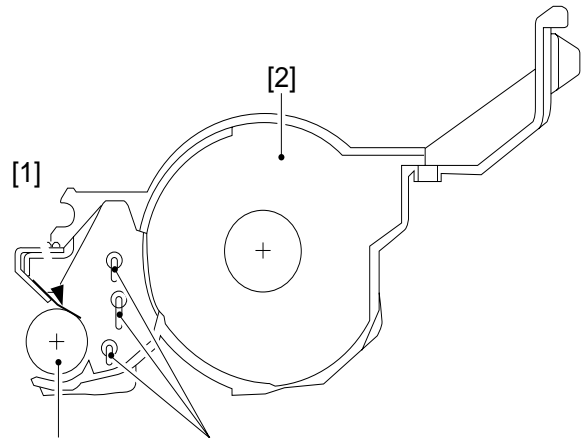

Figure 4-315

- 2) After entering the setting, execute 'U7' in user mode.

## D. Developing Assembly

### 1. Construction



[1] Blade [3] Stirring rod  
[2] Hopper assembly [4] Developing cylinder

**Figure 4-316**

### 2. Removing the Developing Assembly

- 1) Open the machine's top unit, and remove the two screws [1]; then, remove the front upper cover [2].

**Caution:**

The flexible cable for the control panel is connected to the front upper cover; disconnect the flexible cable from the DC controller.

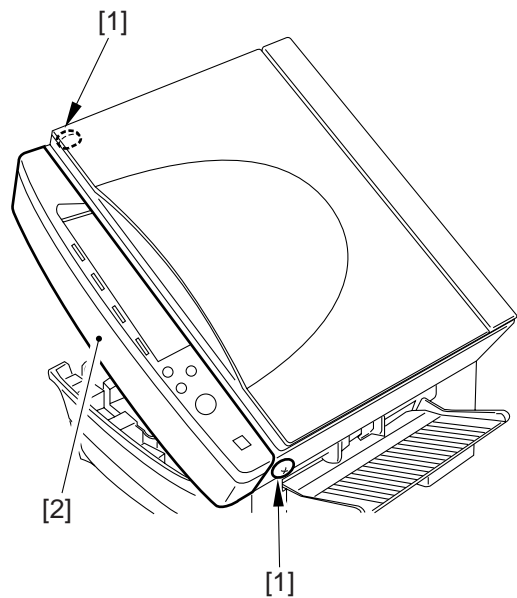

**Figure 4-317**

- 2) Remove the drum unit.  
(See A.2. "Removing the Drum unit.")
- 3) Turn the toner cartridge [3] clockwise.

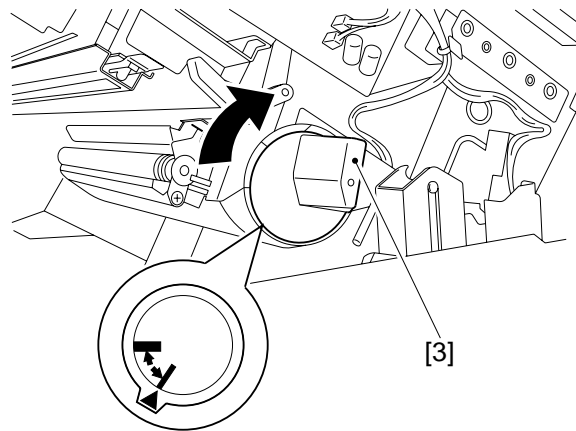

Figure 4-318

- 4) Put a hand under the developing assembly [4], and turn the locking lever [5] counter-clockwise.
  - Turning the locking lever disengages the developing assembly.

**Caution:**

Take care not to touch the developing cylinder.

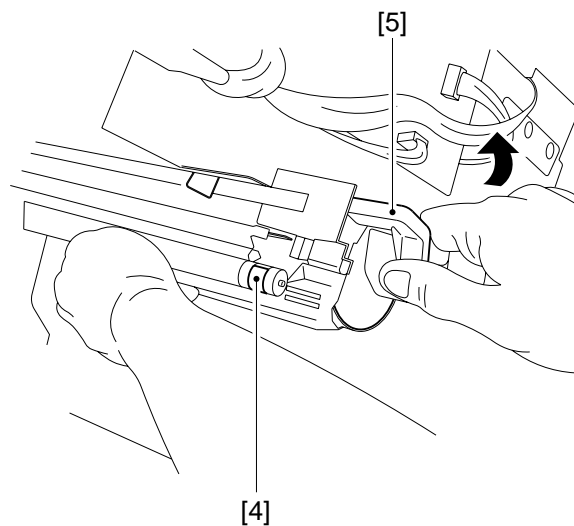

Figure 4-319



### 3. Installing the Developing Assembly

- 1) Insert the hook [1] of the developing assembly into the hole [2] the machine's top unit.

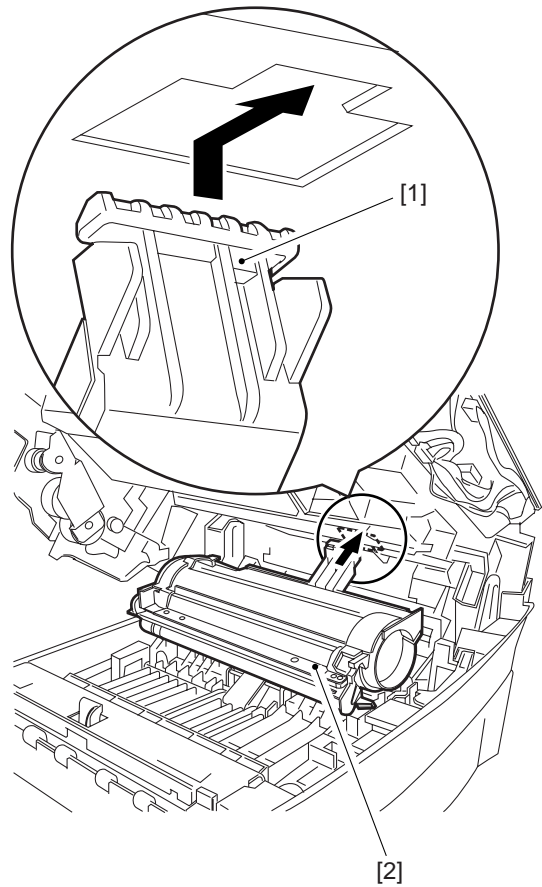

Figure 4-320

- 2) While working as in step 1), lift the developing assembly and butt the groove [4] of the developing assembly against the hooks [3] at the rear and the front.

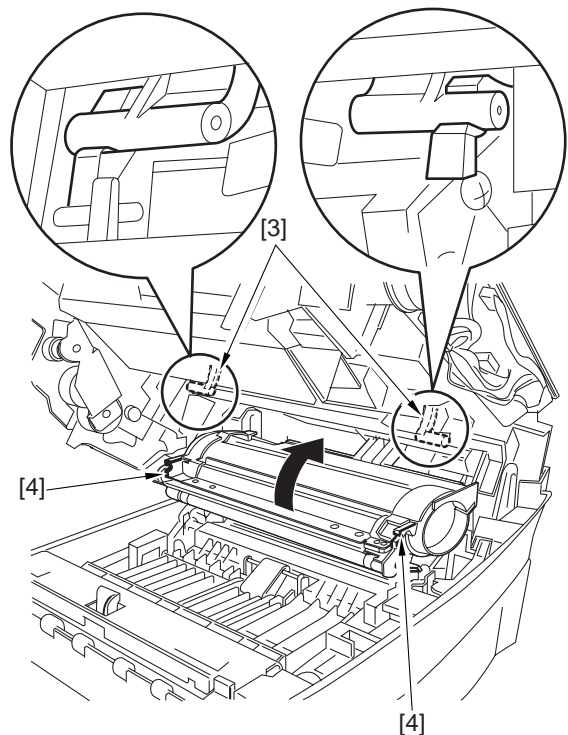

Figure 4-321

- 3) While working as in step 2), turn the locking lever [5] clockwise for a single notch.
  - The developing unit will be fixed in position while it remains unlocked.

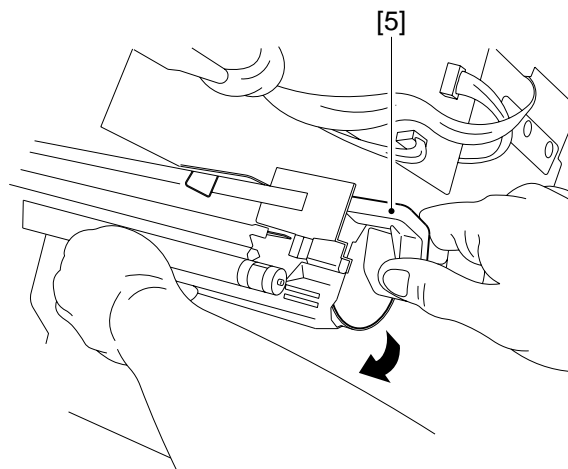

Figure 4-322

#### 4. Removing the Developing Cylinder

- 1) Remove the developing assembly.  
(See D.2. "Removing the Developing Assembly.")
- 2) Turn the toner cartridge [1] clockwise, and pull it out slowly toward the front.

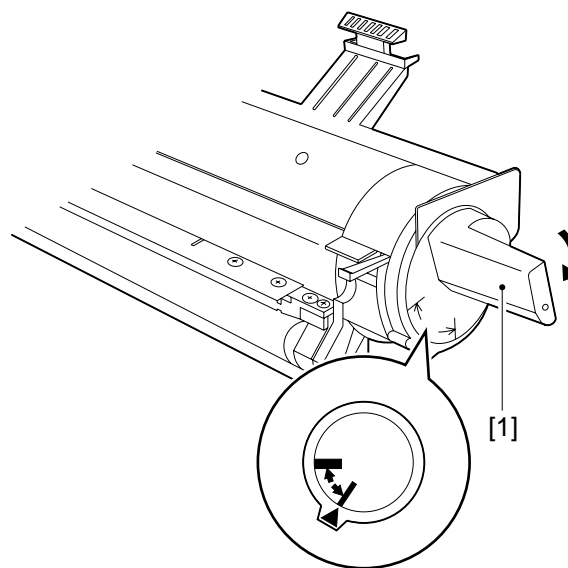

Figure 4-323

- 3) Clean the area around the toner cartridge you have removed.

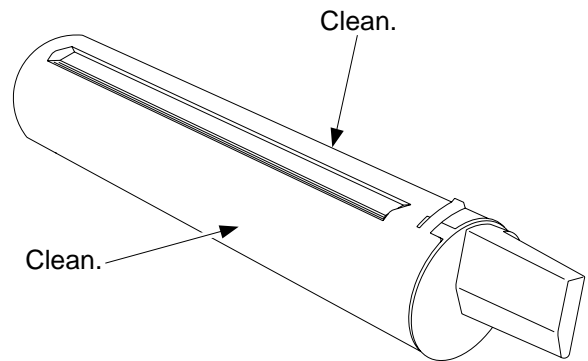

Figure 4-324

- 4) Remove the five screws [2], and remove the cover [3].

**Caution:**

Take care not to damage the developing cylinder and the blade when removing the cover.

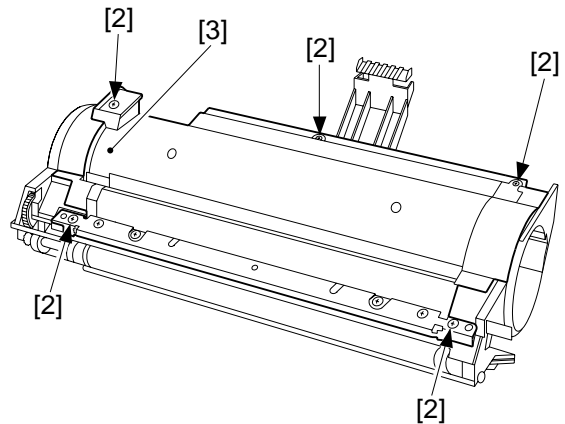

Figure 4-325

- 5) Place a newspaper on the floor, and pour out the toner from the developing cylinder.
- 6) Remove the two screws [4], and remove the gear support plate [5] from the rear.

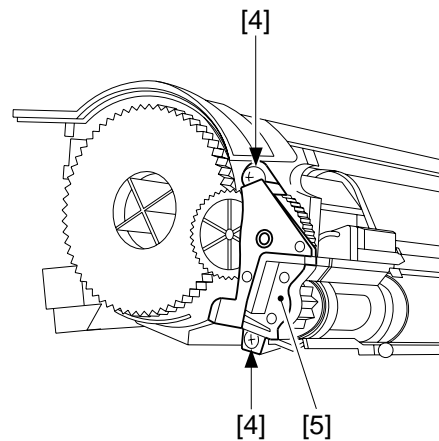

Figure 4-326

- 7) Remove the two screws [6], and remove the developing cylinder support plate [7] at the front.

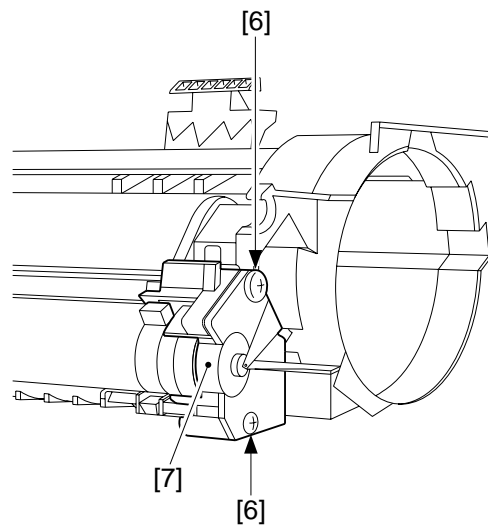

Figure 4-327

- 8) Remove the gear [8], gear [9], bearing [10], and spacer [11]; then, remove the developing cylinder [12].

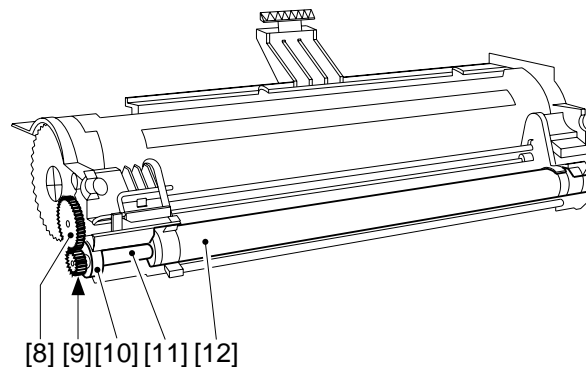

Figure 4-328

## 5. Points to Note When Installing the Developing Cylinder

- a. Clean the compartment in the developing assembly used to store the toner cartridge.
- b. Do not leave fingerprints or oils on the surface of the developing cylinder. If necessary, dry wipe the surface with lint-free paper.
- c. When installing the developing assembly cover, perform the following:
  - 1) Apply a thin coating of toner on the blade [1] with a flannel cloth.

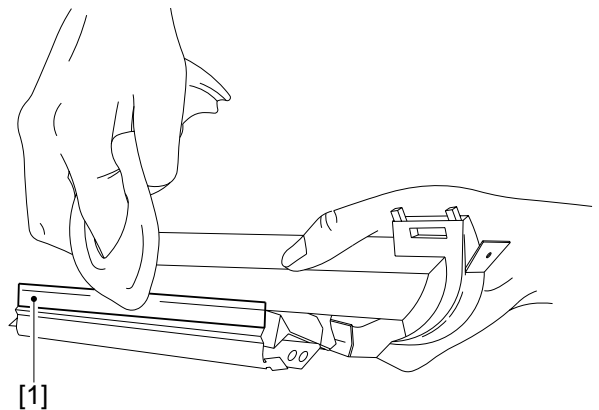

Figure 4-329

- 2) Install the developing assembly cover, and tighten the five screws lightly; then, tighten the screws in the order shown in the figure.

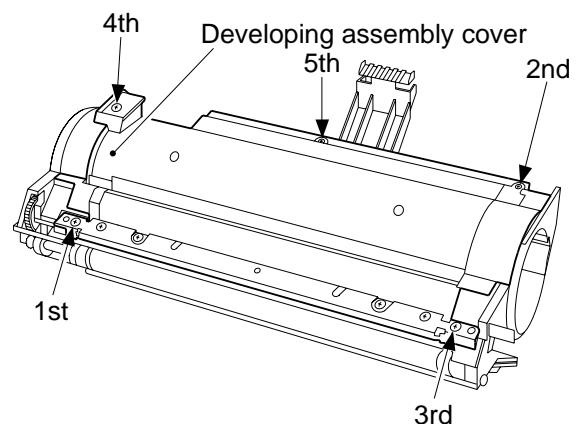

Figure 4-330

- 3) Turn the drive gear [4] slowly in the direction shown in the figure to give the developing cylinder a full turn.

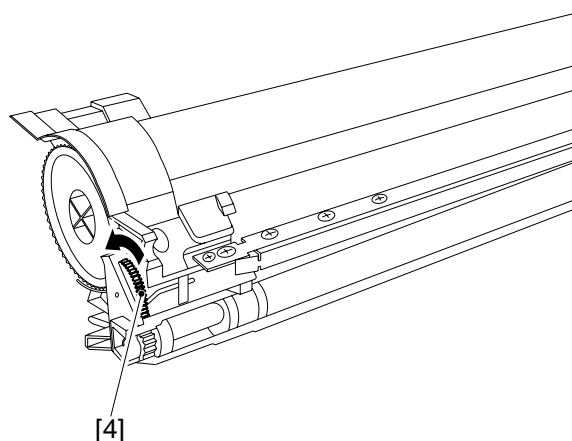

Figure 4-331

**6. Points to Note When Installing the Drive Gear**

- a. Assemble the gears so that all three stirring rods [1] face the same direction.

**Caution:**

If any of the stirring rods does not face the same direction, the interference among the rods can prevent stirring operation.

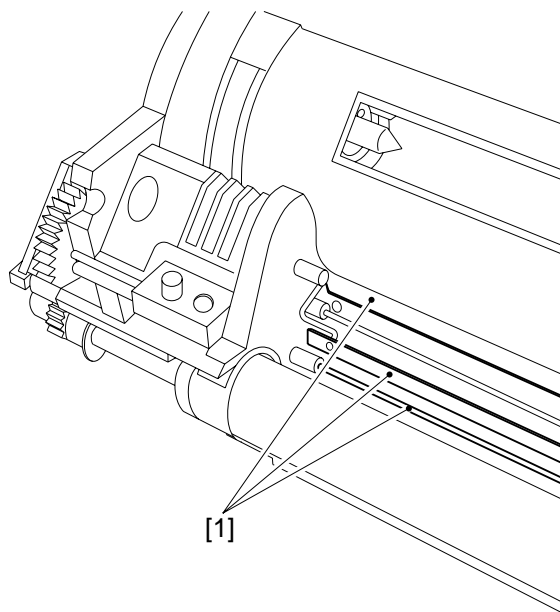

Figure 4-332

---

# CHAPTER 5

---

## PICK-UP/FEEDING SYSTEM

---

This chapter explains the principles used from when copy paper is picked up to when a copy is delivered in view of the functions of electrical and mechanical units and in relation to their timing of operation. It also shows how these units may be disassembled/assembled and adjusted.

I. PICKUP/FEEDING SYSTEM.....	5-1	II. DISASSEMBLY/ASSEMBLY .....	5-13
A. Outline .....	5-1	A. Pickup Assembly .....	5-14
B. Controlling the Pickup Roller .....	5-2	B. Multifeeder Assembly .....	5-21
C. Controlling the Movement of Paper .....	5-6	C. Feeding Assembly .....	5-24
D. Detecting Jams .....	5-8	D. Registration Roller Assembly .....	5-25
		E. Delivery Assembly .....	5-30





# I. PICKUP/FEEDING SYSTEM

## A. Outline

The machine moves paper using a center reference method, in which paper is moved in the middle of the pickup/feeding path, and is equipped with a cassette, and multifeeder as the source of paper.

From the cassette, or multifeeder, copy paper is picked up and is controlled by the registration roller so that its leading edge will match the leading edge of the image on the photosensitive drum; it is then moved through the transfer, separation, feeding, and fixing assemblies to reach the copy tray.

The machine is equipped with three sensors used to monitor the movement of copy paper.

Notation	Name	Remarks
PS3	Delivery sensor	
PS4	Vertical path roller paper sensor	
Q751	Pre-registration roller paper sensor	

Table 5-101

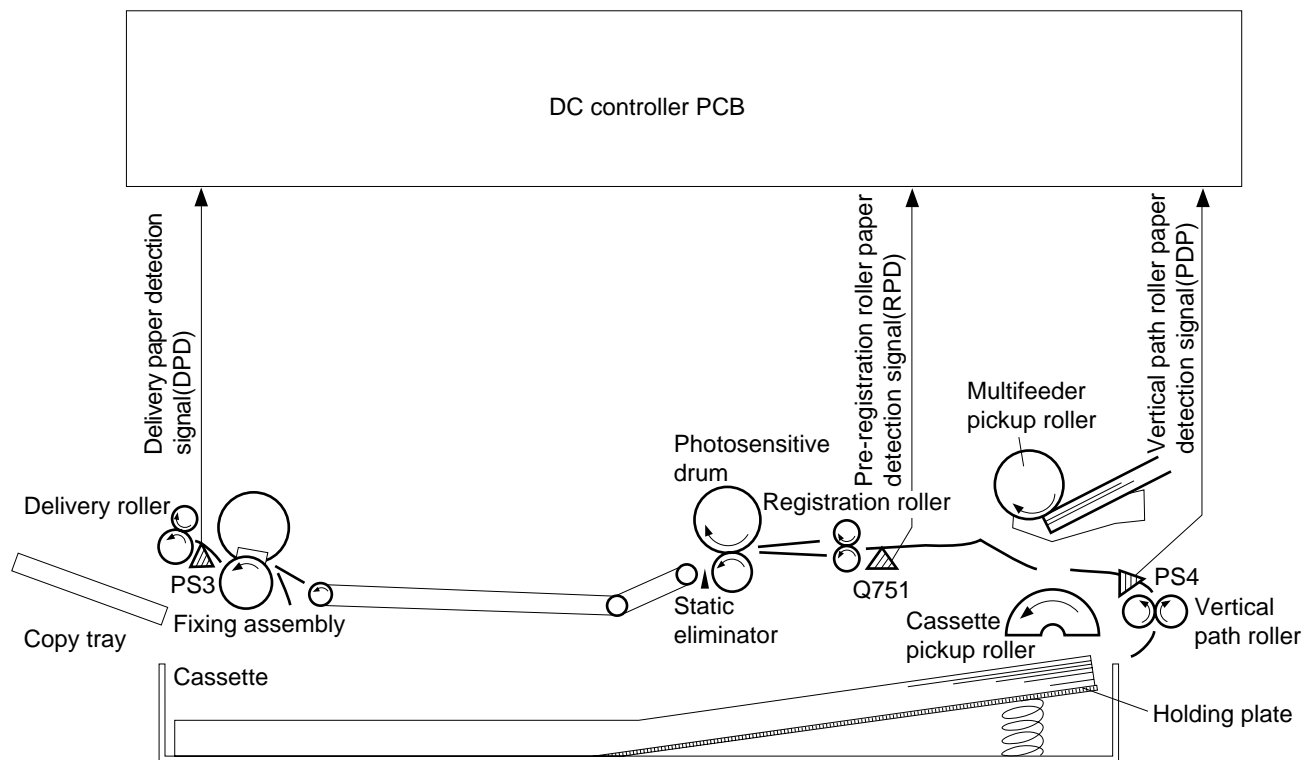

Figure 5-101

## B. Controlling the Pickup Roller

### 1. Outline

The machine has two types of pickup rollers, i.e., cassette pickup roller, and multifeeper pickup roller, and each of these rollers are operated by the drive of the main motor switched by means of a gear unit. (In other words, only one roller is driven at any one time.)

### 2. Controlling the Cassette Pickup Roller

The cassette pickup roller is controlled by a spring clutch, control ring, pickup clutch solenoid (SL1), and cassette pickup solenoid (SL5).

When the pickup clutch solenoid turns on, the claw moves away from the control ring, allowing the drive to move to the pickup gear assembly through the spring clutch. Then, when the cassette pickup solenoid turns on, the drive reaches the cassette pickup roller.

When the cassette pickup roller starts to rotate, copy paper is picked up from the cassette and is sent as far as the registration roller by way of the vertical path roller. The registration roller controls paper so that its leading edge will match the leading edge of the image on the photosensitive drum.

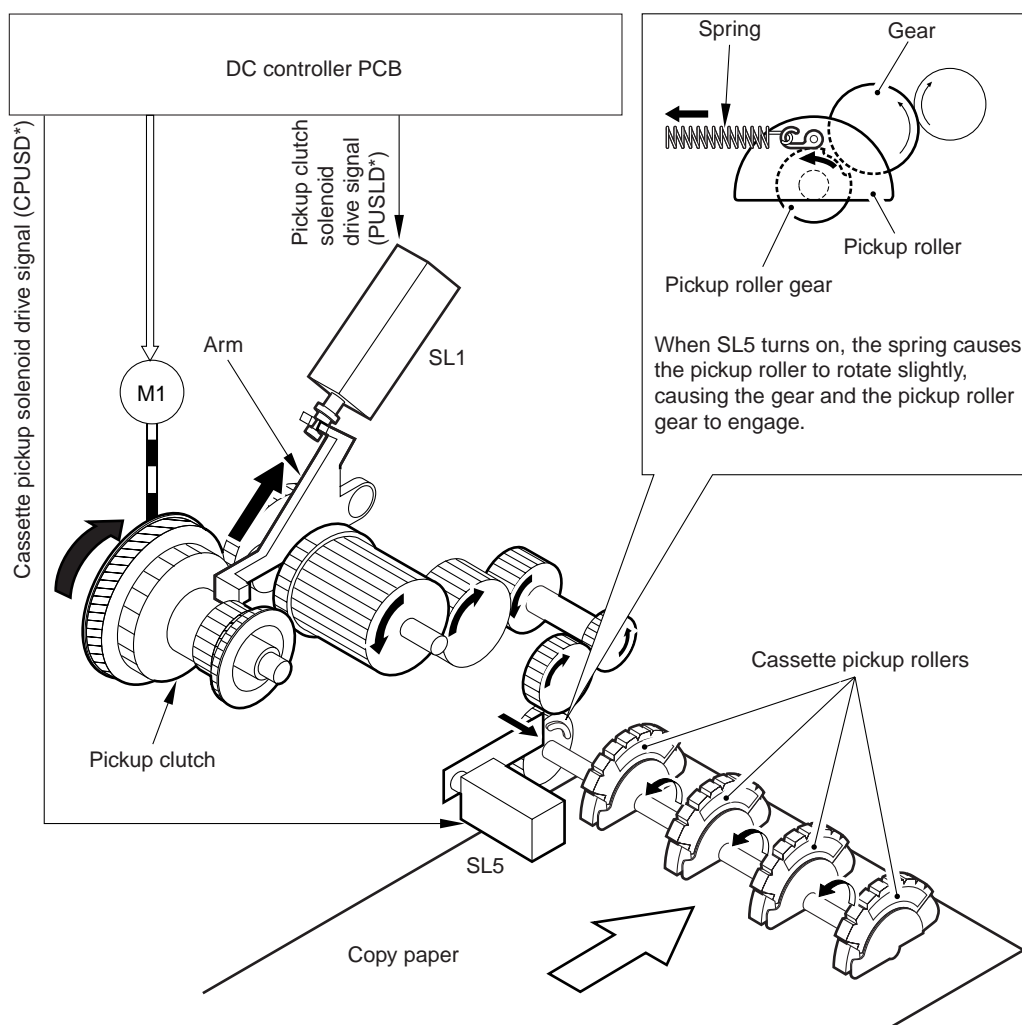
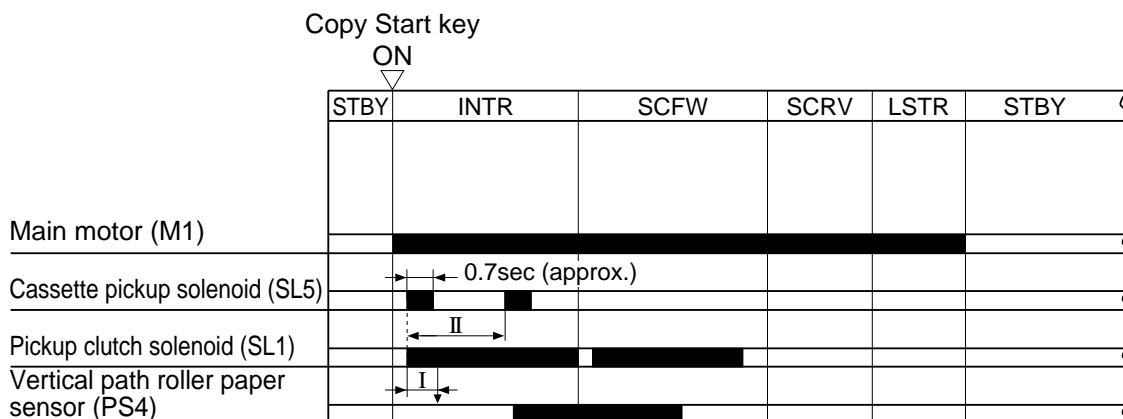

Figure 5-102

### 3. Re-Pickup (cassette pickup)

If the vertical path roller paper sensor (PS4) does not detect copy paper within a specific period of time after the cassette pickup roller has started to rotate, the pickup roller is rotated once again to execute pickup operation, thereby ensuring correct pickup (as for recycled paper).

If the vertical path roller paper sensor does not detect copy paper after re-pickup, the machine will assume the absence of copy paper and will indicate "P" in the count/ratio indicator in the control panel. (This mechanism substitutes a paper detecting mechanism.)



- I: Re-pickup operation is executed if the vertical path roller paper sensor (PS4) does not detect copy paper within 0.5 sec after the pickup clutch solenoid (SL1) has turned on.
- II: The cassette pickup solenoid (SL5) turns on once again about 1.3 sec after the pickup clutch solenoid (SL1) turns on.

Figure 5-103

#### 4. Controlling the Multifeeder Pickup Roller

The multifeeder pickup roller is controlled by a spring clutch, control ring, pickup clutch solenoid (SL1), gear unit, and multifeeder pickup solenoid (SL4).

When the multifeeder pickup solenoid (SL4) turns on, the drive of the main motor (M1) reaches the cam gear. When the cam gear starts to rotate in response, the lifter, which is in contact with the cam, moves up the gear unit and, at the same time, pushes down the paper guide plate. The cam gear makes a 180° turn (approximate), and stops at the toothless section.

When the pickup solenoid turns on in this condition, the claw leaves the control ring, and the drive of the main motor (M1) reaches the multifeeder pickup roller.

When the multifeeder pickup roller rotates, paper is picked up and sent as far as the registration roller, which controls the paper so that its leading edge will match the leading edge of the image on the photosensitive drum.

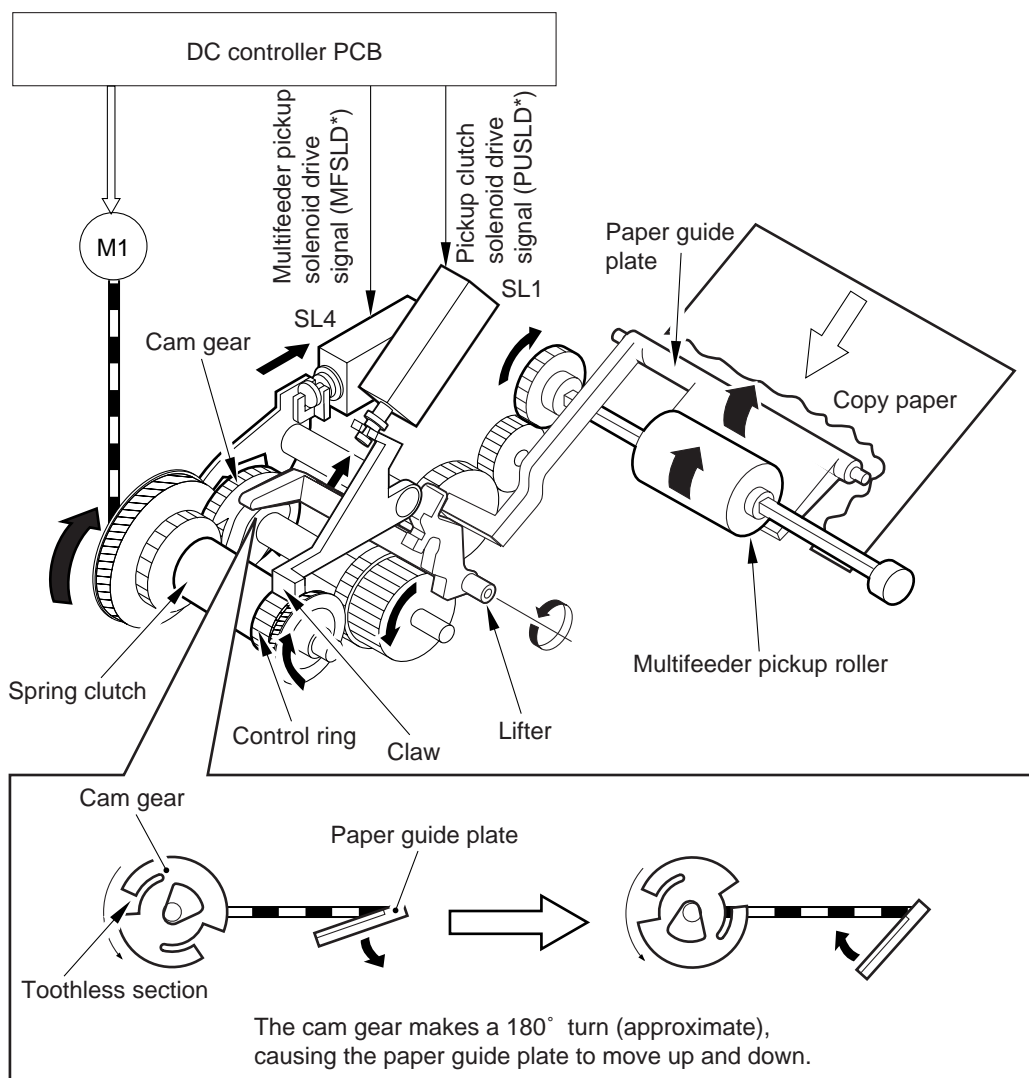

Figure 5-104

### 5. Controlling the Copying Speed in Multifeeder Mode

The machine does not possess a copy paper width detecting function and, therefore, the temperature of the ends of the fixing assembly increases when copies are made continuously on paper narrower than A4/LTR.

When the multifeeder is used for continuous copying, a delay is initiated after picking up the 19th sheet so as to increase the sheet-to-sheet distance for the sheets that follow, controlling the copying speed to 9 cpm.

If the copying speed is controlled (to 6 cpm) by a mechanism to prevent overheating of the copyboard, this control will not be executed, and moreover if the temperature of the copyboard increases during 9-cpm control, 6-cpm control will be initiated.

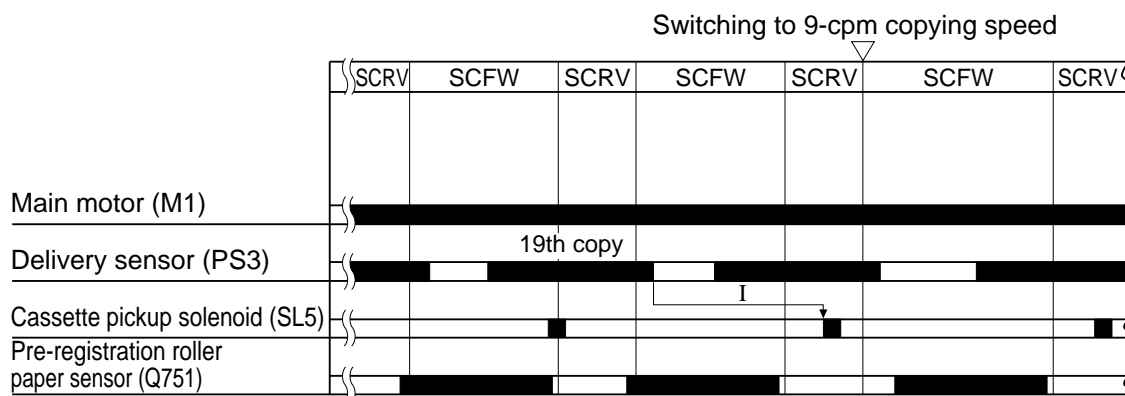

Figure 5-105

## C. Controlling the Movement of Paper

### 1. Controlling the Registration Roller

The registration roller is controlled by a spring clutch, control ring, pre-registration roller paper sensor (Q751), and registration clutch solenoid (SL2).

The microprocessor on the DC controller PCB turns on the registration clutch solenoid at a specific timing in response to the paper detection signal from the pre-registration roller paper sensor. When the registration clutch solenoid turns on, the claw will leave the control ring, and the drive of the main motor will reach the registration roller to move the copy paper to the photosensitive drum.

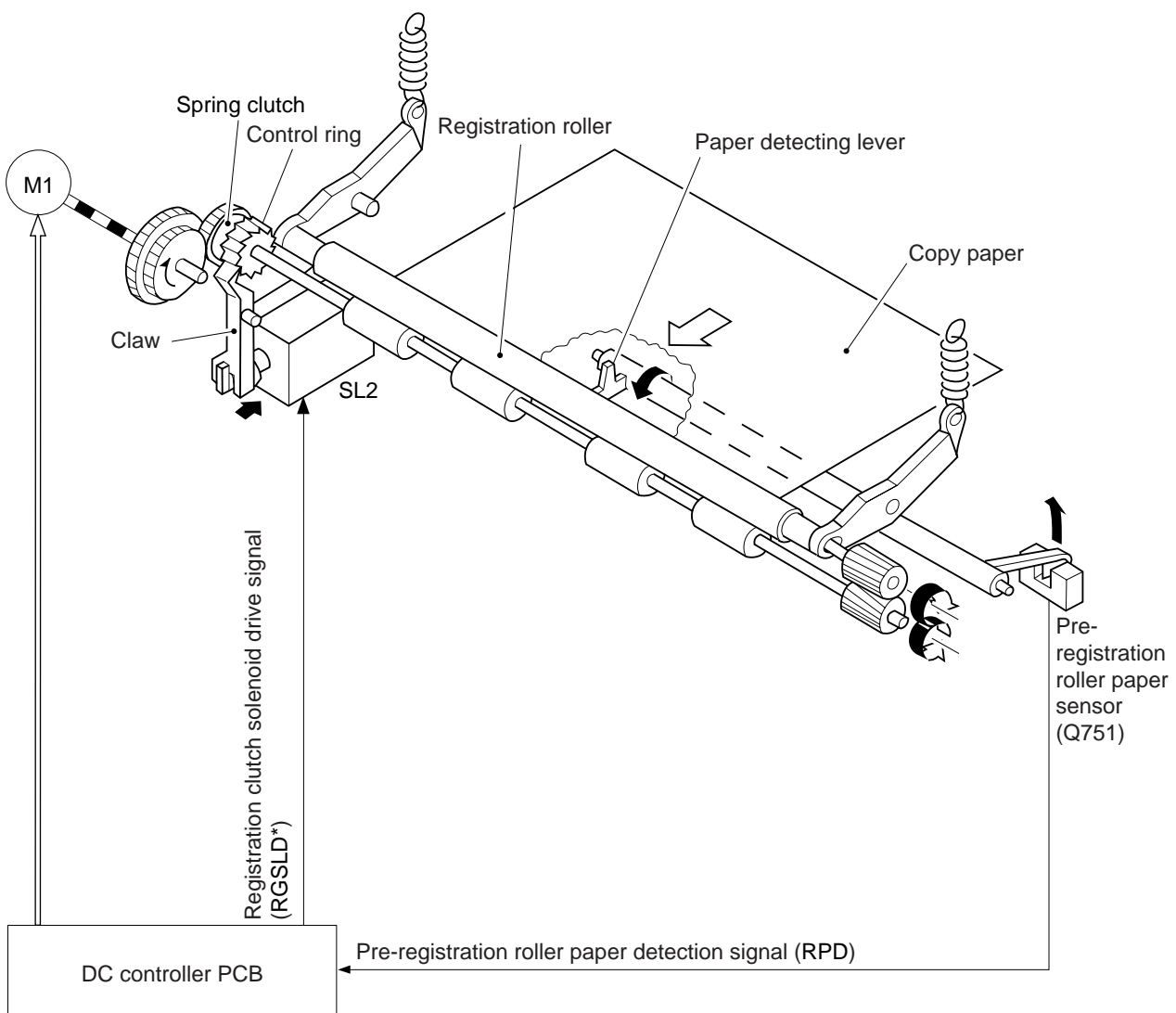

Figure 5-106

2. Pickup/Feeding Timing Chart

a. Pickup from the Cassette (A4, 2 copies)

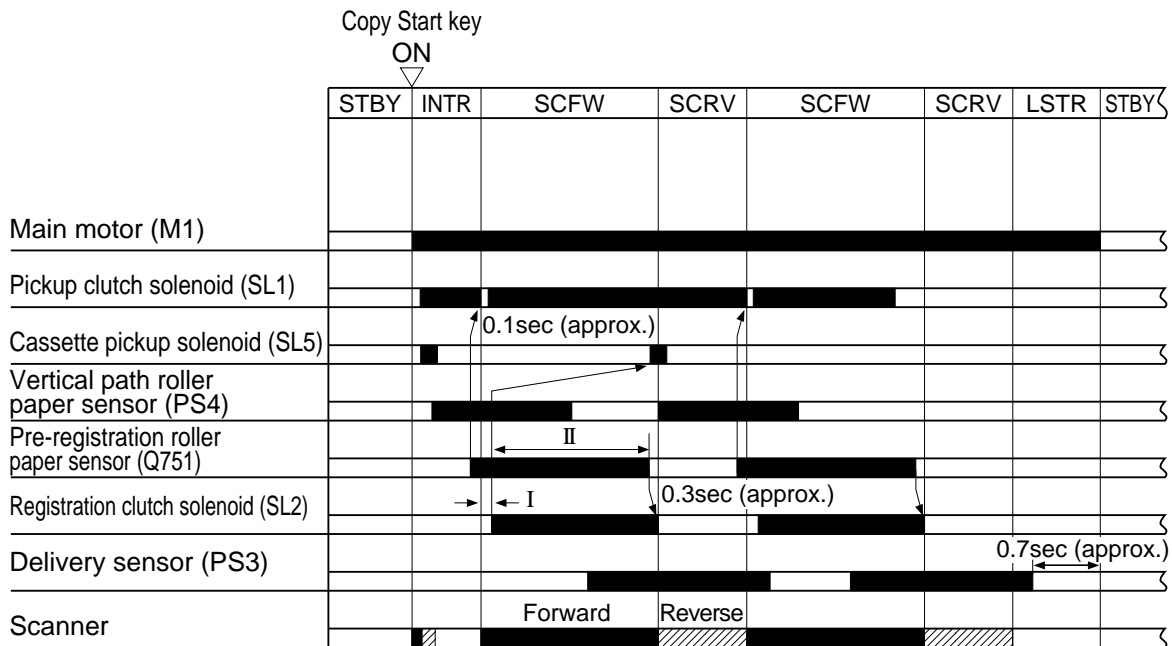
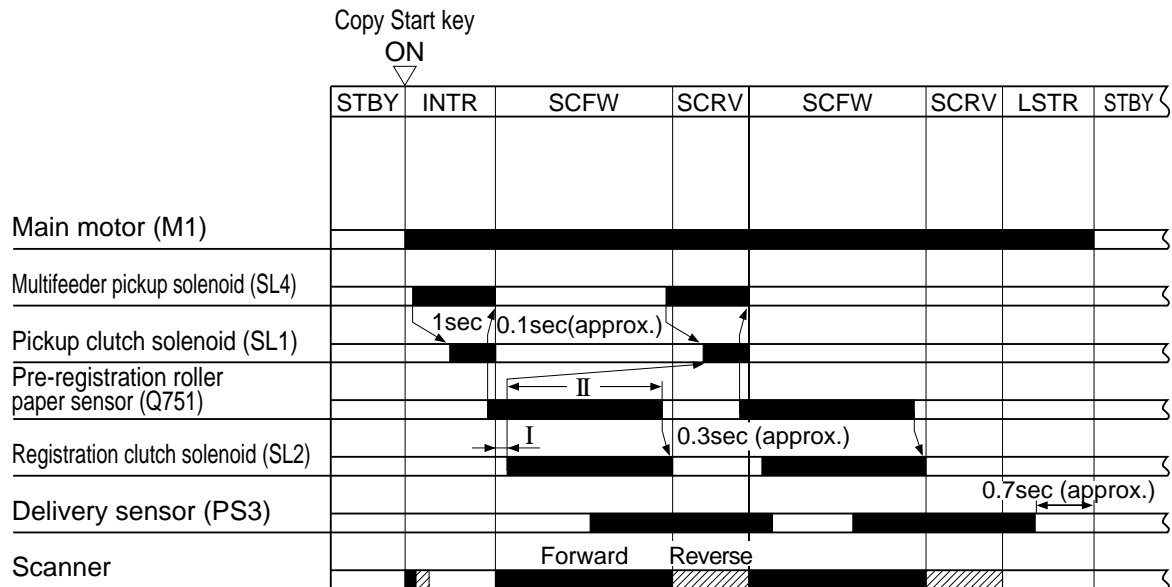

Figure 5-107

b. Pickup from the Multifeder (A4, 2 copies)



I: Varied by value under '30' of service mode (registration adjustment).

II: Used for measuring the length of copy paper.

$$\text{length of copy paper (mm)} = 96 \text{ (mm/s)} \times \text{II (s)} + 11 \text{ (mm)} - 10 \text{ (mm)}$$

96 (mm/s): speed at which copy paper is moved.

11 (mm): distance between pre-registration roller paper sensor and registration roller.

10 (mm): length of actuator of the pre-registration roller paper sensor.

Figure 5-108

## D. Detecting Jams

The machine is equipped with three paper sensors used to find out the presence/absence of copy paper and whether copy paper is moving properly.

- Vertical path roller paper sensor (PS4)
- Pre-registration roller paper sensor (Q751)
- Delivery sensor (PS3)

The presence/absence of a jam is checked with reference to the presence/absence of paper over a specific sensor at such times as programmed in the microprocessor.

The machine keeps a record of the remaining number of copies to make or the copy mode effective at time of a jam.

The microprocessor possesses the following seven types of no paper/jam detection sequence; if any of its sensors detects copy paper at power-on, the machine will identify the condition as a jam.

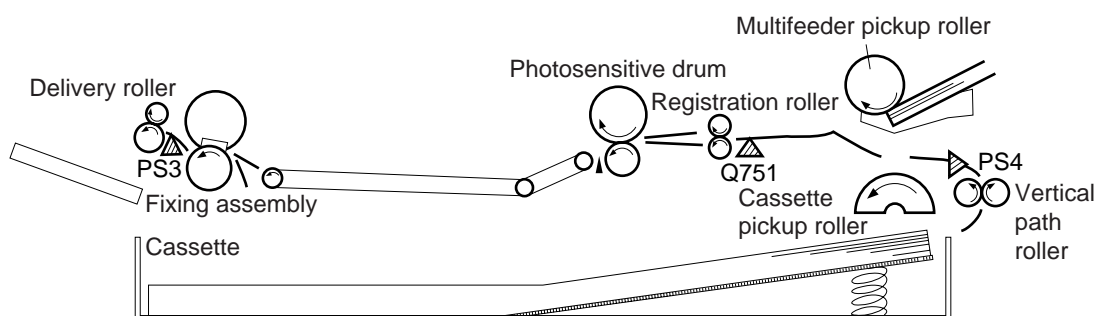

Figure 5-109

### 1. Multifeed Pickup Assembly (no paper, pickup delay jam)

If copy paper does not reach the pre-registration roller paper sensor within a specific period of time in multifeed mode, the condition will be identified as the absence of paper; the machine will stop the main motor in about 1.5 sec, and indicate the Add Paper message.

If the pre-registration roller paper sensor detects copy paper during this 1.5 sec period (approximate), the machine will identify the condition as a pickup delay jam, and flash the Jam indicator.



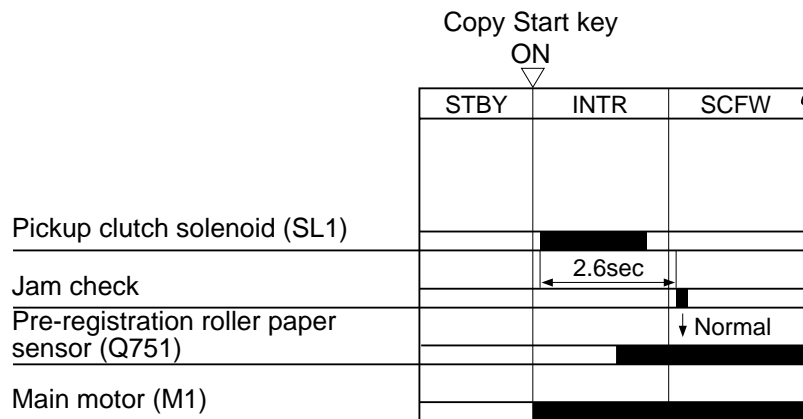

Figure 5-110 (normal)

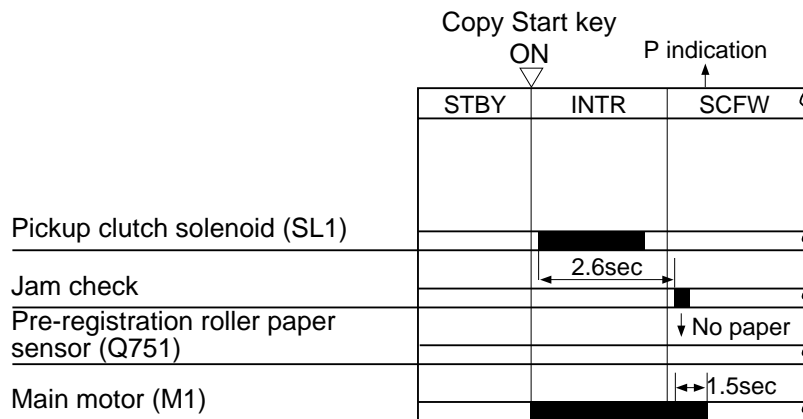

Figure 5-111 (no paper)

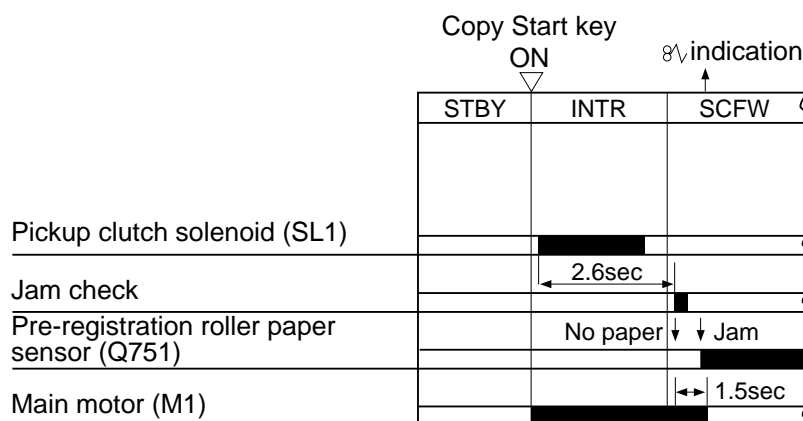

Figure 5-112 (jam)

### 2. Absence of Paper in the Cassette Pickup Assembly

When re-pickup operation is executed (from the cassette), the absence of paper will be identified if copy paper does not reach the vertical path roller paper sensor within a specific period of time. In response, the machine will stop the main motor in about 1.5 sec, and indicate the Add Paper message.

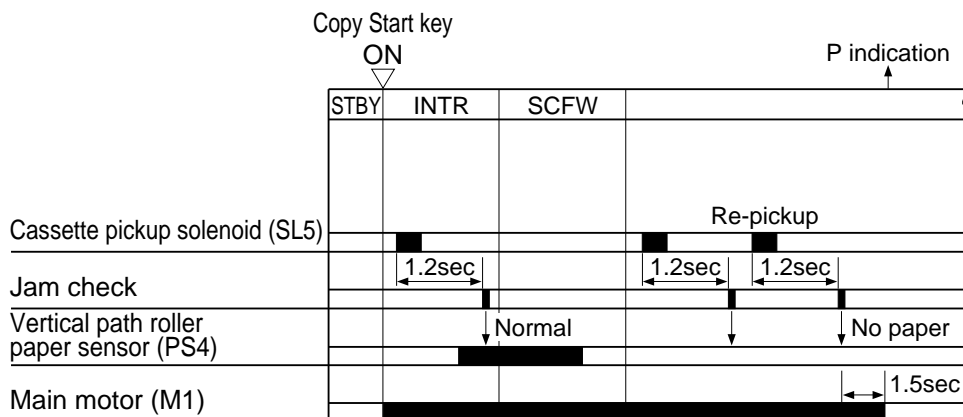

Figure 5-113

### 3. Vertical Path Stationary Jam

If copy paper fails to move past the vertical path roller paper sensor within a specific period of time because of faulty feeding, the machine will identify the condition as a vertical path stationary jam, stop the operation, and flash the Jam indicator.

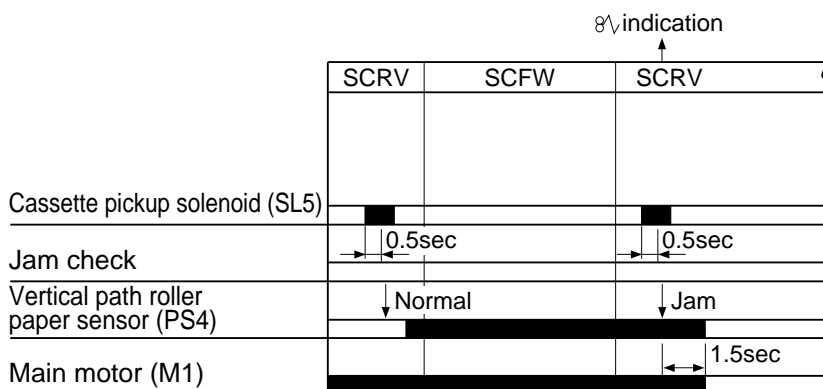

Figure 5-114

#### 4. Registration Paper Delay Jam

After reaching the vertical path roller paper sensor, if copy paper fails to reach the pre-registration roller paper sensor within a specific period of time, the machine will identify the condition as a registration paper delay jam, stop the operation immediately, and flash the Jam indicator.

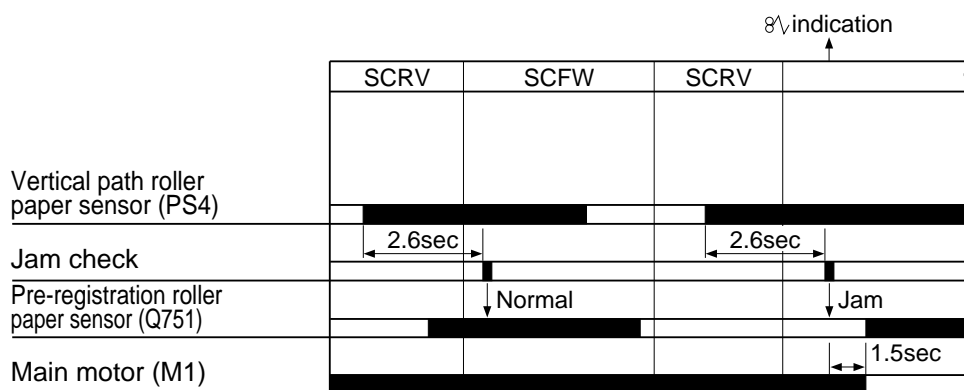

Figure 5-115

#### 5. Registration Paper Stationary Jam

If copy paper does not move past the pre-registration roller paper sensor within a specific period of time because of feeding faults, the machine will identify the condition as a registration paper stationary jam, stop the operation immediately, and flash the Jam indicator.

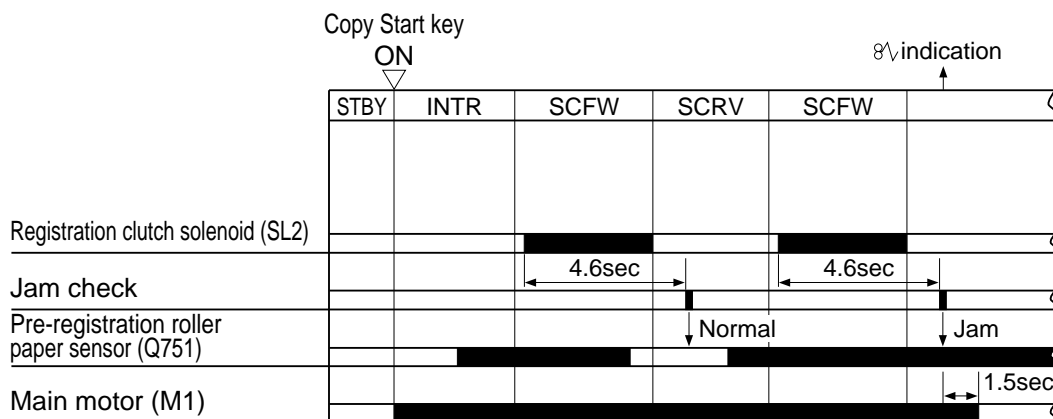

Figure 5-116

### 6. Delivery Delay Jam

If copy paper does not reach the delivery sensor within a specific period of time because of feeding faults, the machine will identify the condition as a delivery delay jam, stop the operation immediately, and flash the Jam indicator.

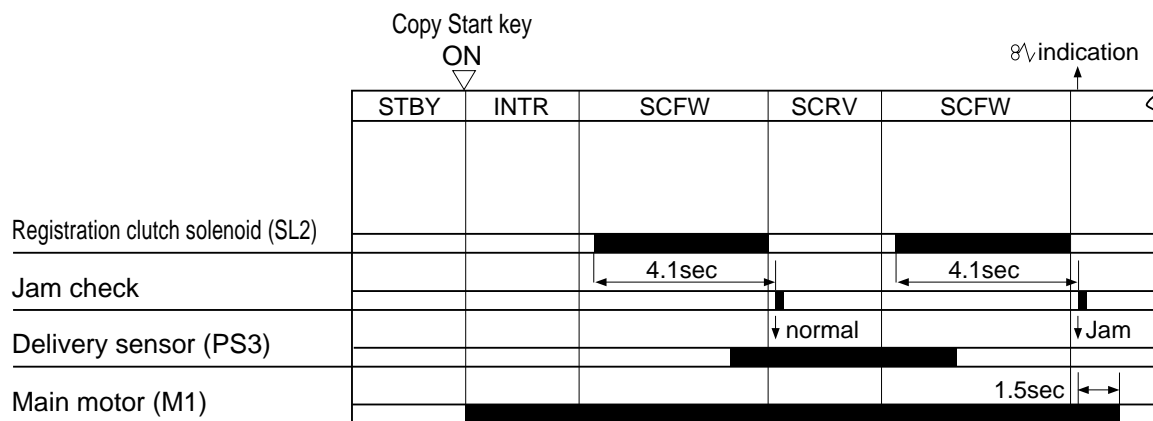

Figure 5-117

### 7. Delivery Stationary Jam

If copy paper does not move past the delivery sensor within a specific period of time because of feeding faults, the machine will identify the condition as a delivery stationary jam, stop the operation immediately, and flash the Jam indicator.

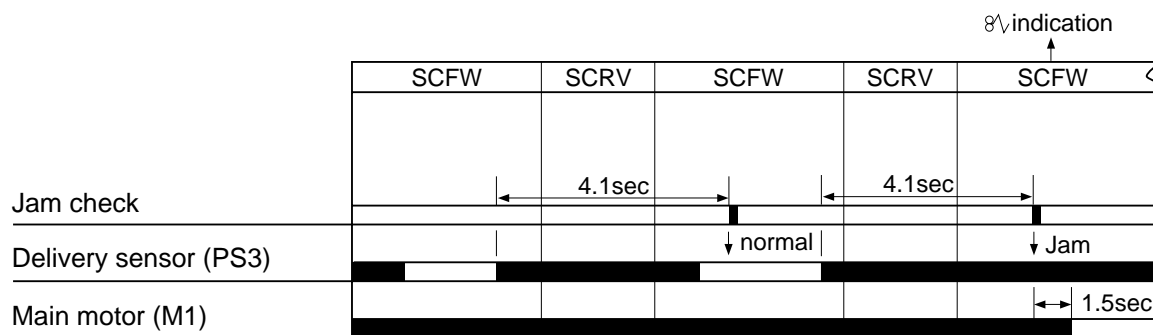

Figure 5-118

## II. DISASSEMBLY/ASSEMBLY

As needed, disassemble/assemble the machine with the following in mind:

1. **▲** Before starting the work, turn off the power switch and disconnect the power plug for safety.
2. Unless otherwise instructed, assemble the parts by reversing the steps used to disassemble it.
3. Identify the screws by type (length, diameter) and location.
4. Use the washers where necessary. (The screws used to mount the grounding wire and Varistors come with a washer to ensure electrical continuity.)
5. As necessary, cut the harness band.
6. As a rule, do not operate the machine with any of its part removed.
7. A few of the screws used are special screws (with wider thread intervals). Do not use any screws indiscriminately.

## A. Pickup Assembly

### 1. Removing the Pickup Roller

- 1) Pull out the cassette.
- 2) Remove the front lower cover.  
(See Chapter 7.III.A.2. "Removing the Front Lower Cover.")
- 3) Open the machines' top unit farther, and hold it in place with the handle of a screwdriver (about 30 mm in diameter).

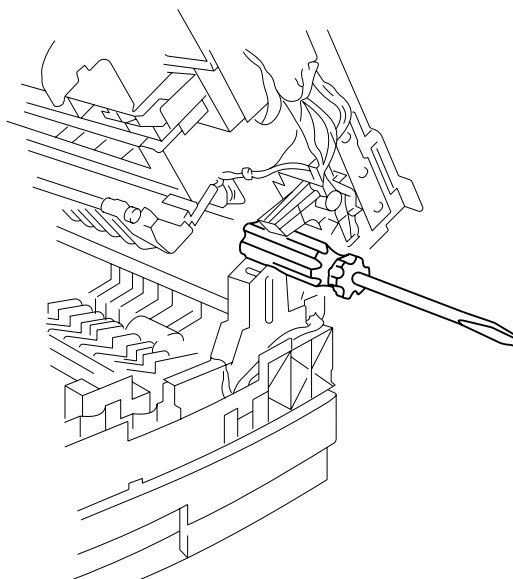

Figure 5-201

- 4) Remove the screw [1], and free the two claws [2]; then, detach the feeding assembly cover [3].

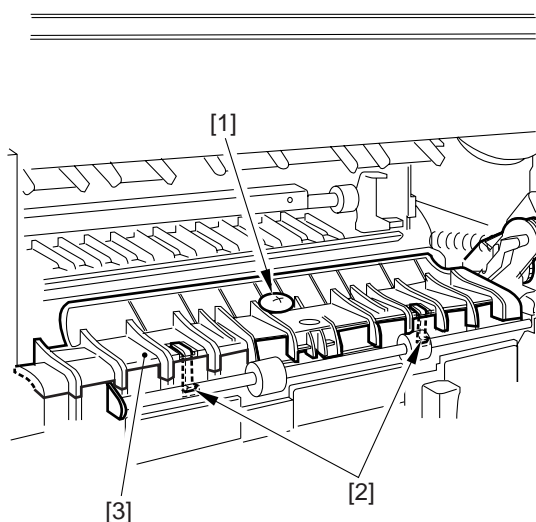

Figure 5-202

- 5) While pulling the guide plate [4] of the cassette pickup solenoid in the direction of the arrow, turn the gear [5] slightly in the direction of the arrow to disengage the guide plate [4] and the gear [6].

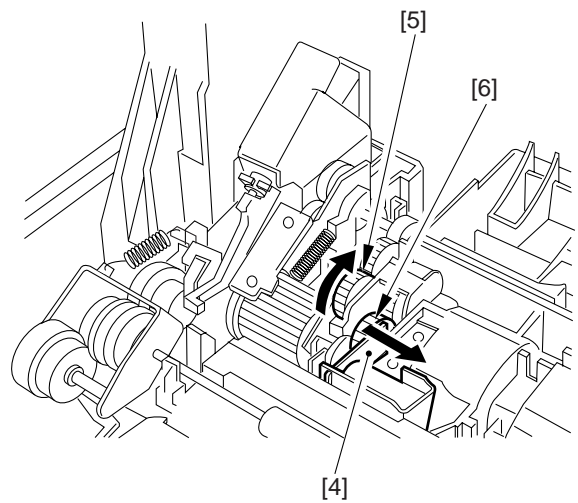

Figure 5-203

- 6) While pulling the plunger [7] of the pickup solenoid, turn the gear [8] in the direction of the arrow so that the pickup roller [9] is oriented as shown.

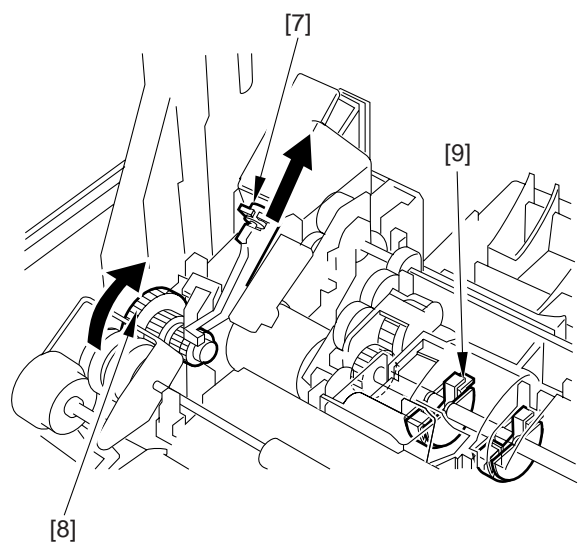

Figure 5-204

- 7) Using a hex wrench or the like, push the hook [10] of the pickup roller through the hole to remove the pickup roller [11].

**Caution:**

When removing the pickup roller, be sure to push the claw while holding the shaft in place so as to prevent the pickup roller shaft from freeing itself.

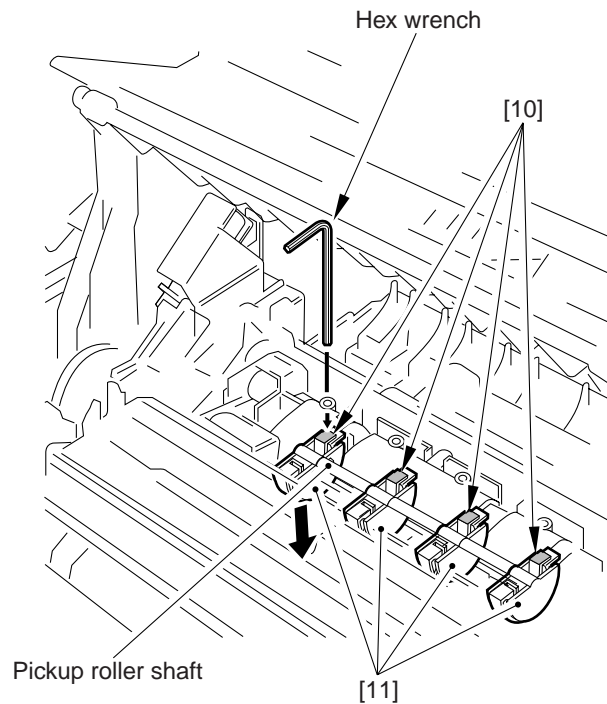

Figure 5-205

**Caution:**

When mounting the multifeeder unit, perform the next steps first:

- 1) Turn on the power switch; then, select the multifeeder, and press the Copy Start key.
- 2) When the pickup gear unit has moved up as far as it can, turn off the power switch.
- 3) Mount the multifeeder; then, make a copy using the multifeeder.

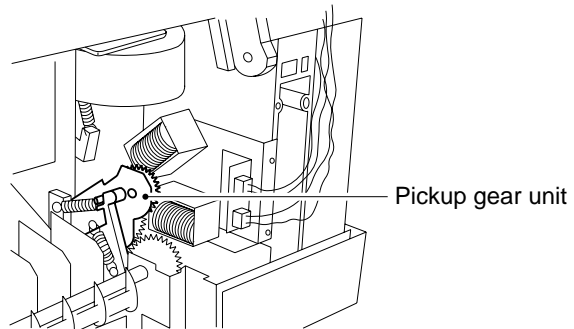

Figure 5-206



## 2. Removing the Pickup Clutch

- 1) Remove the front lower cover.  
(See Chapter 7.III.A.2. "Removing the Front Lower Cover.")
- 2) Remove the registration roller unit.  
(See D.1. "Removing the Registration Roller Unit.")
- 3) Open the machine's top unit farther, and hold it in place with the handle of a screwdriver (about 30 mm in diameter).

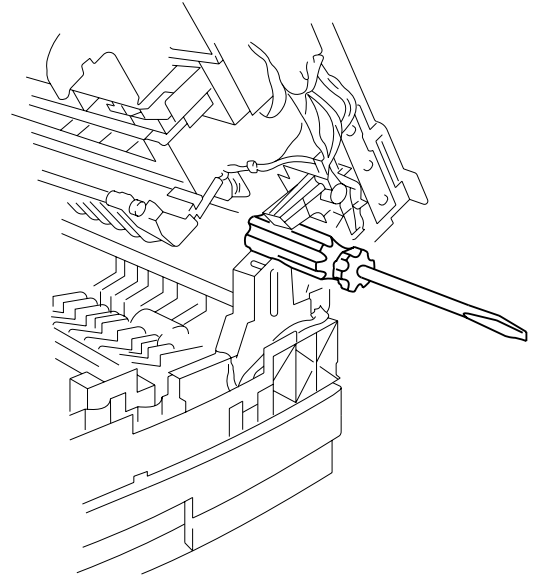

Figure 5-207

- 4) Disconnect the two connectors [1], and remove the two screws [2] then, detach the solenoid unit [3].

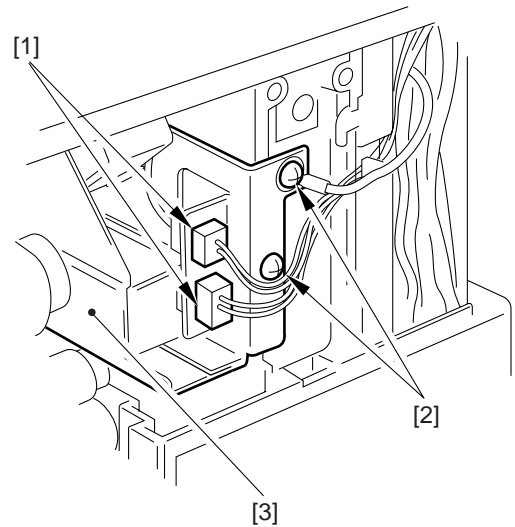

Figure 5-208

- 5) While freeing the two claws [4], remove the pickup clutch unit [5].

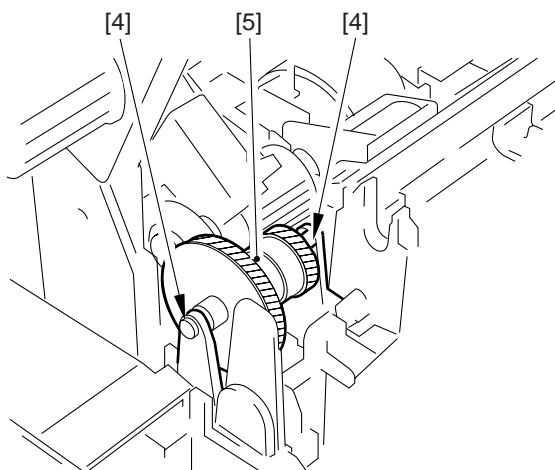

Figure 5-209

- 6) Remove the E-ring [6], and detach the pickup clutch [7].

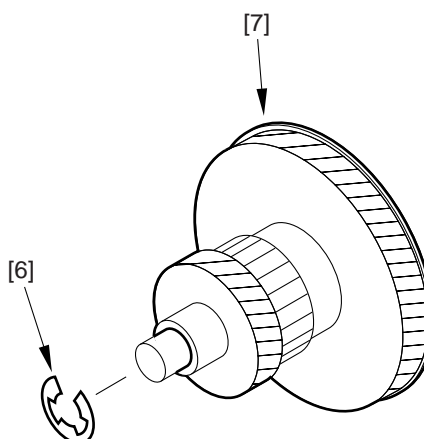

Figure 5-210

### 3. Removing the Vertical Path Roller

- 1) Remove the front lower cover.  
(See Chapter 7.III.A.2. "Removing the Front Lower Cover.")
- 2) Open the machine's top unit farther, and hold it in place with the handle of a screwdriver (about 30 mm in diameter).

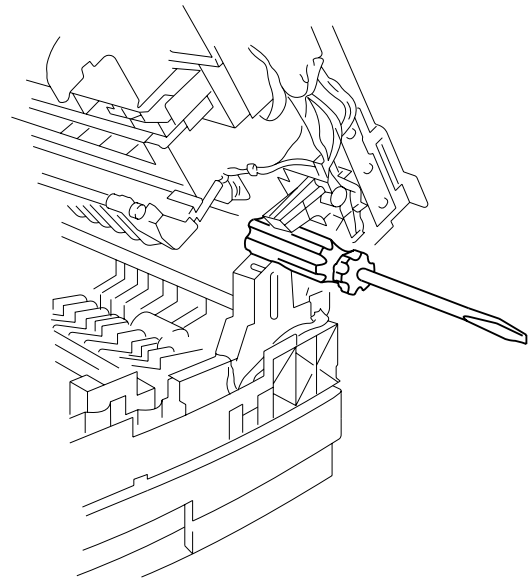

Figure 5-211

- 3) Remove the screw [1], and free the two claws [2]; then, detach the feeding assembly cover [3].

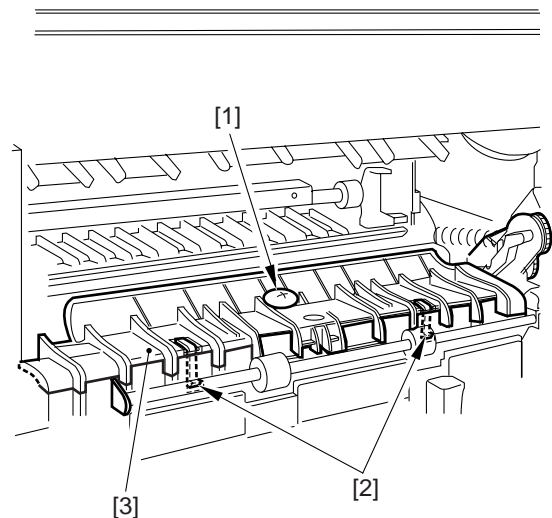

Figure 5-212

- 4) While lifting the sensor lever [4], remove the vertical path roller [5].

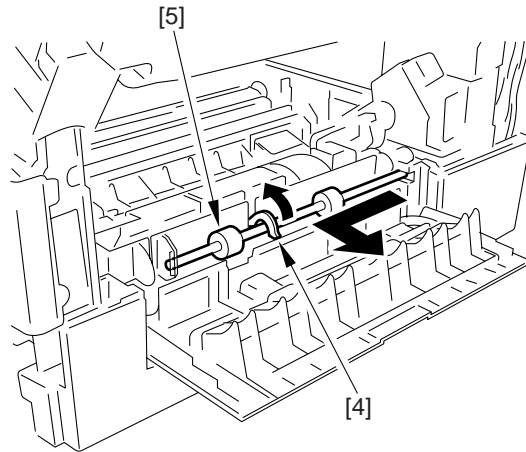

Figure 5-213

## B. Multifeeder Assembly

### 1. Removing the Multifeeder Unit

- 1) Open the right door.
- 2) Remove the two screws [1], and detach the multifeeder unit [2].

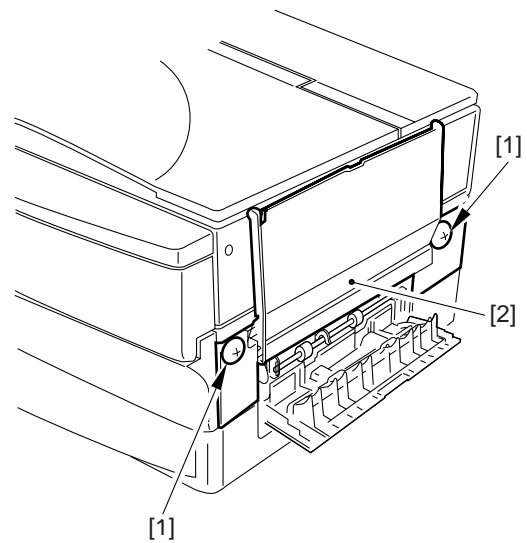

Figure 5-214

#### Caution:

When mounting the multifeeder unit, perform the following first:

- 1) Turn on the power switch; then, select the multifeeder, and press the Copy Start key.
- 2) When the pickup gear unit has moved as far as it can, turn off the power switch.
- 3) Mount the multifeeder unit; then, make a copy using the multifeeder.

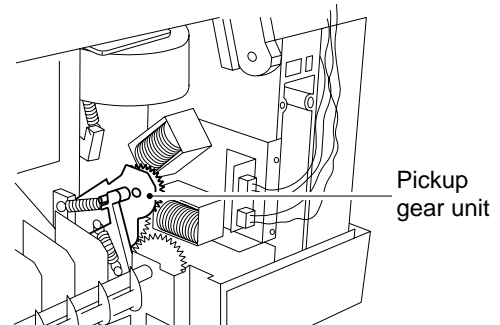

Figure 5-215

## 2. Removing the Multifeeder Pickup Roller

- 1) Remove the multifeeder unit.  
(See 1. "Removing the Multifeeder Unit.")
- 2) Free the claw [1], and remove the gear [2] and the bushing [3].

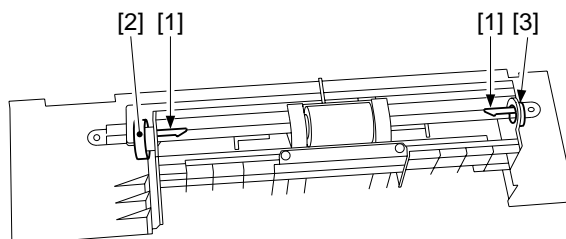

Figure 5-216

- 3) Remove the multifeeder pickup roller unit [4].

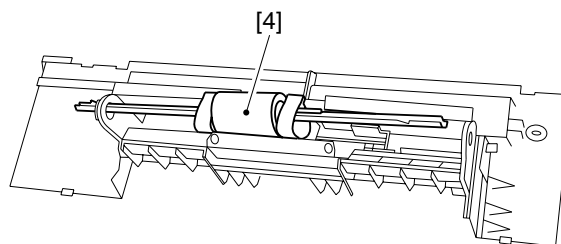

Figure 5-217

- 4) While freeing the claw [5], detach the multifeeder pickup roller [6].

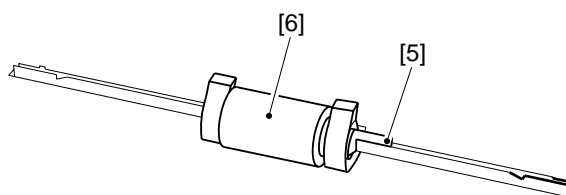

Figure 5-218

### 3. Removing the Separation Pad

- 1) Remove the multifeeder pickup roller together with its shaft.  
(See 2. "Removing the Multifeeder Pickup Roller.")
- 2) Remove the multifeeder tray.
- 3) Slide the side guide [1] to the inside about 3 cm, and free the two claws [2]; then, detach the holding plate [3].

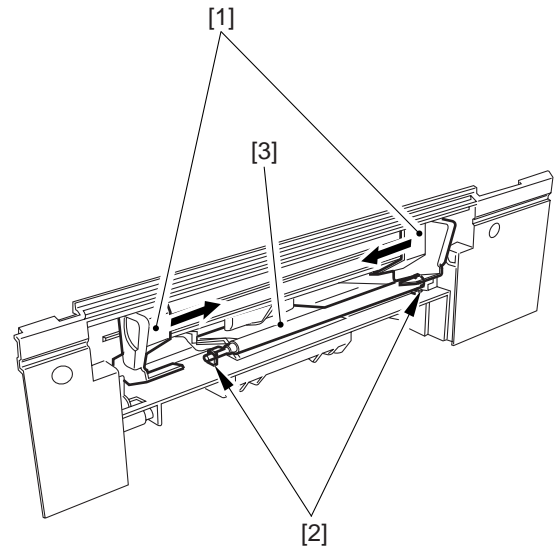

Figure 5-219

- 4) Push up the separation pad [4], and pull it out by pushing the shaft [5] toward the inside.

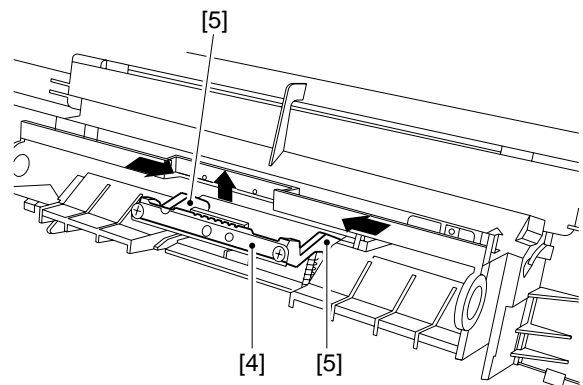

Figure 5-220

## C. Feeding Assembly

### 1. Detaching the Feed Belt

- 1) Open the machine's top unit.
- 2) Push down the stopper [1], and remove the gear [2].

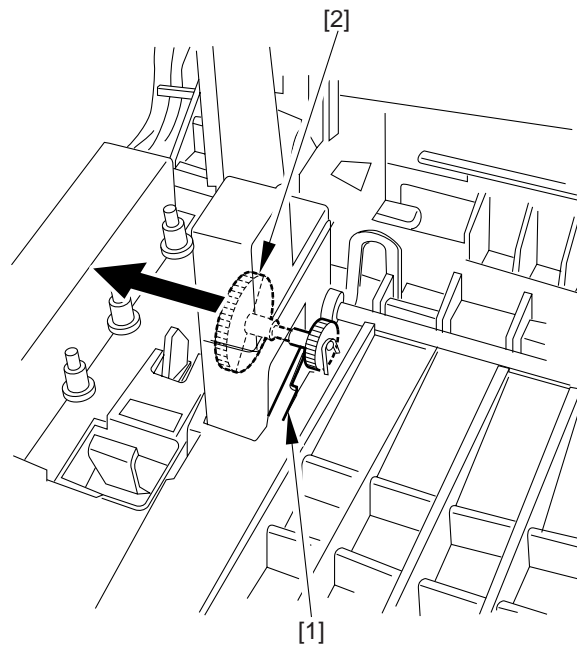

Figure 5-221

- 3) While freeing the claw [3], detach the four shafts [4]; then, detach the feed belt [5].

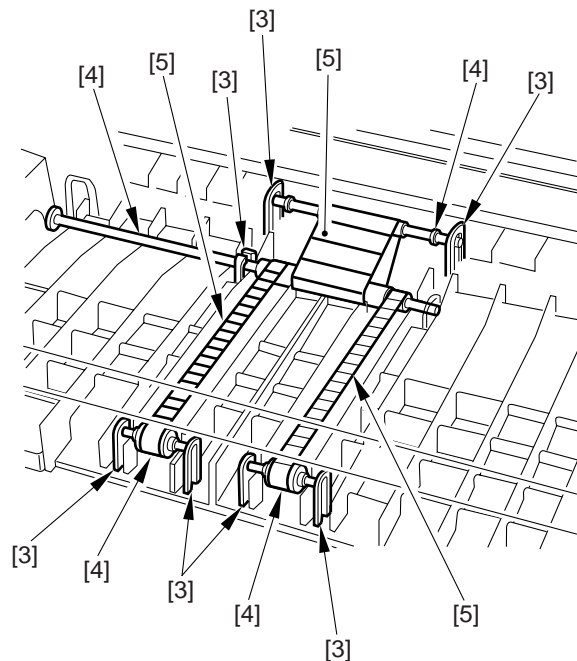

Figure 5-222



## D. Registration Roller Assembly

### 1. Removing the Registration Roller Unit

- 1) Remove the front lower cover.  
(See Chapter 7.III.A.2. "Removing the Front Lower Cover.")
- 2) Open the machine's top unit farther, and hold it in place with the handle of a screw driver (about 30 mm in diameter).

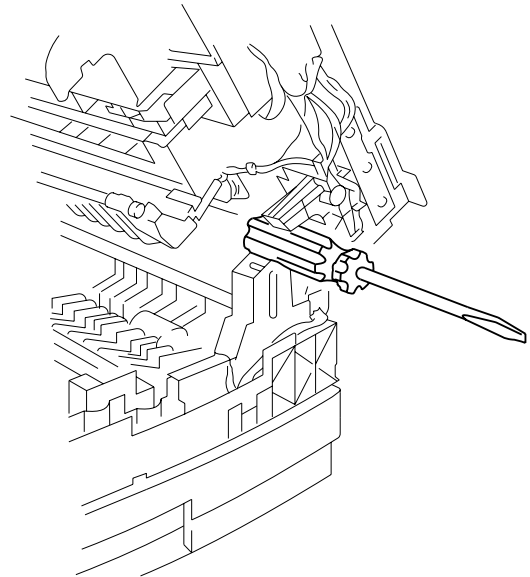

Figure 5-223

- 3) Remove the shaft [1] and the spring [2].

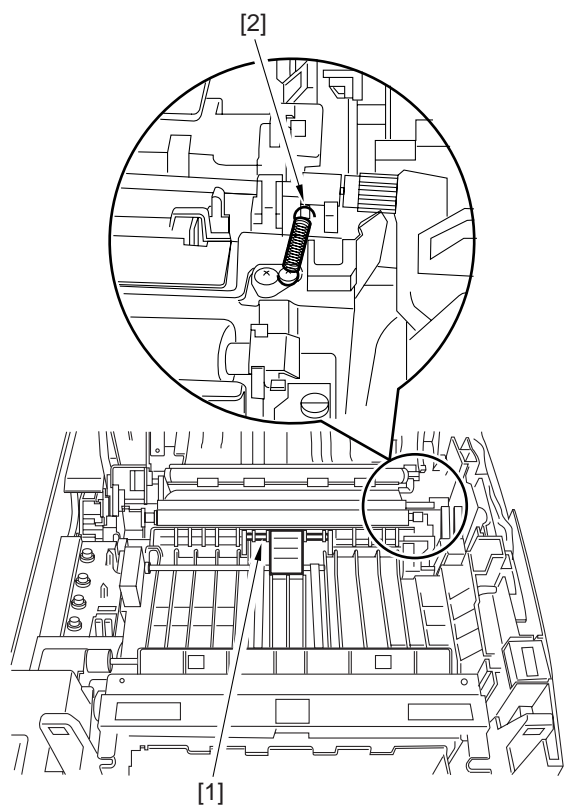

Figure 5-224

- 4) Free the seven claws [3] and remove the transfer mount [4] and the high-voltage terminal unit [5].

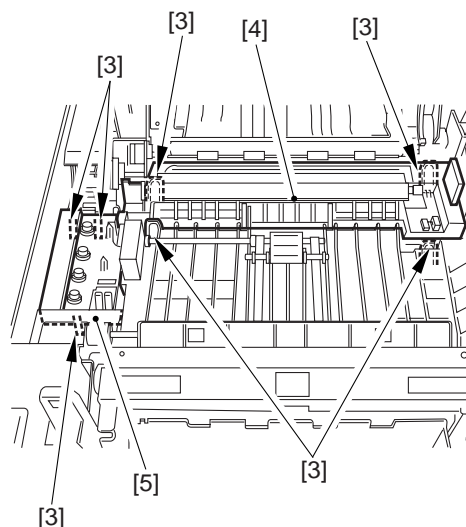

Figure 5-225

- 5) Remove the two springs [6].

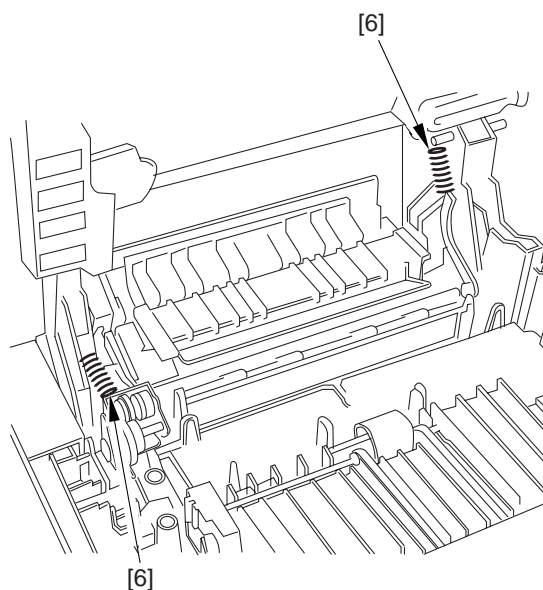

Figure 5-226

- 6) Remove the two springs [7]; then, while freeing the two claws [8], remove the registration roller unit [9].

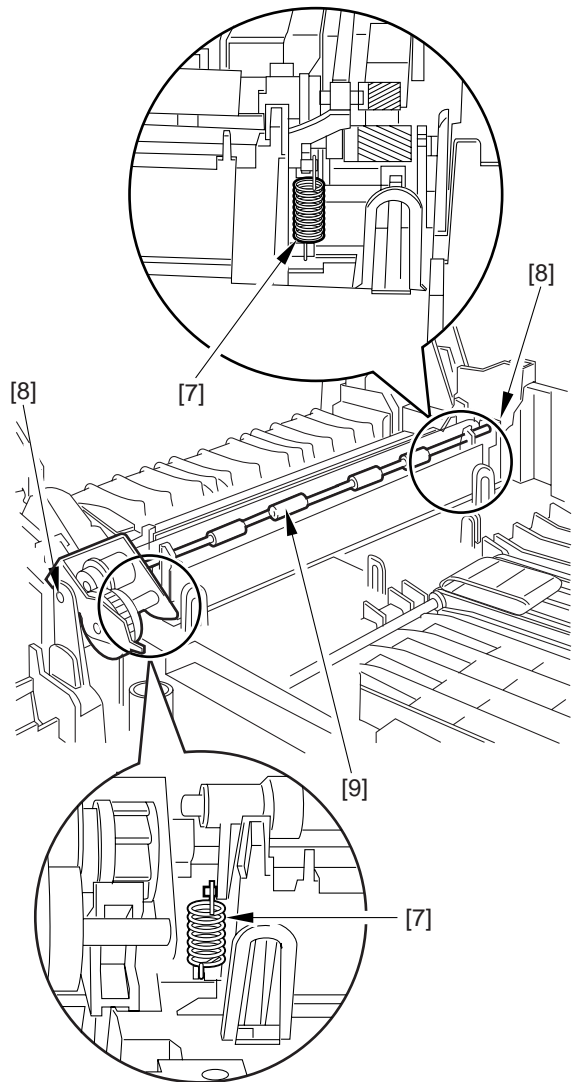

Figure 5-227

## 2. Removing the Registration Roller Clutch

- 1) Remove the registration roller unit.  
(See 1. "Removing the Registration Roller Unit.")
- 2) Remove the E-ring [1] ; then, remove the gear [2] and the arm [3].

**Caution:**

Take care not to drop the pin from the rear of the gear.

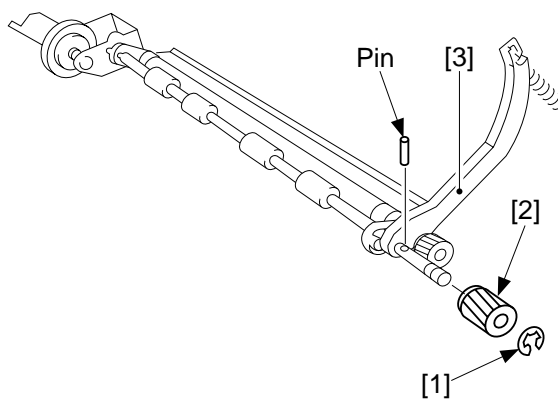

Figure 5-228

- 3) Remove the E-ring [4].

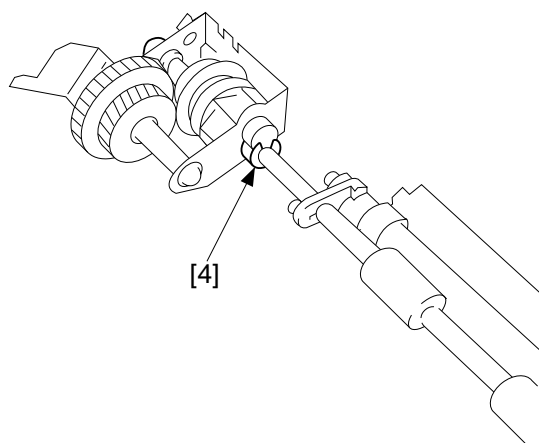

Figure 5-229

- 4) Remove the two bushings [5].

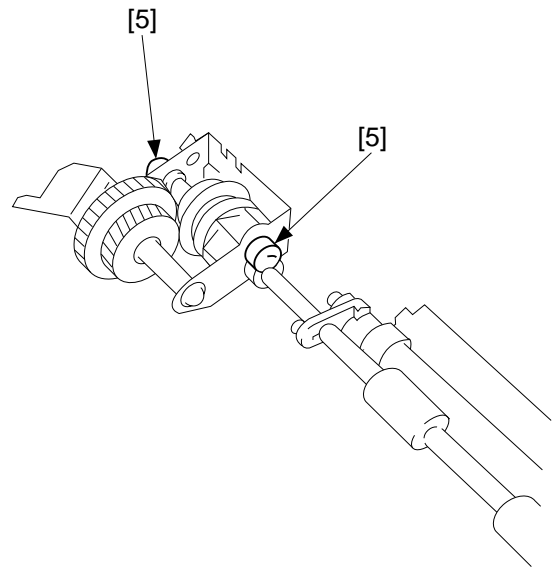

Figure 5-230

- 5) While moving down the registration roller [6], detach it from the gear unit [7].

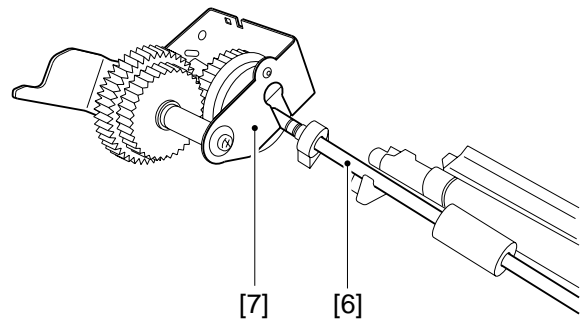

Figure 5-231

- 6) Remove the E-ring [8], and pull out the clutch [9].

**Caution:**

Take care not to lose the pin from the rear of the clutch.

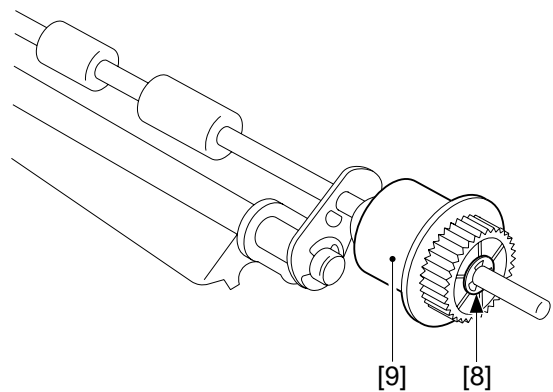

Figure 5-232

## E. Delivery Assembly

### 1. Removing the Delivery Roller

- 1) Remove the fixing lower roller.  
(See Chapter 6.II.A.3. "Removing the Fixing Lower Roller.")
- 2) Remove the two screws [1], and detach the side plate [2] and the four gears [3].

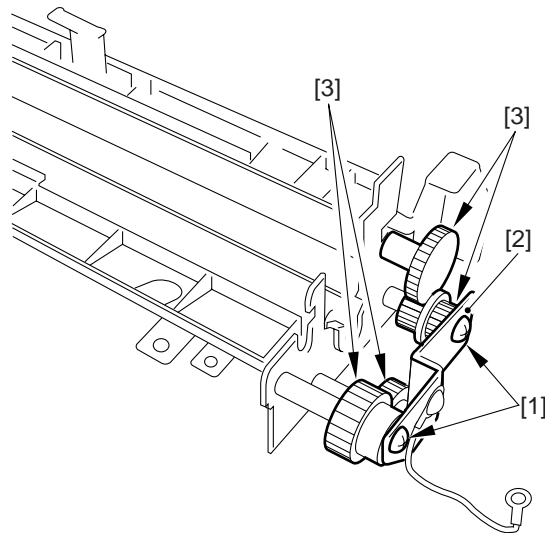

Figure 5-233

- 3) Remove the screw [4], and free the two hooks [5]; then, detach the sensor holder [6].

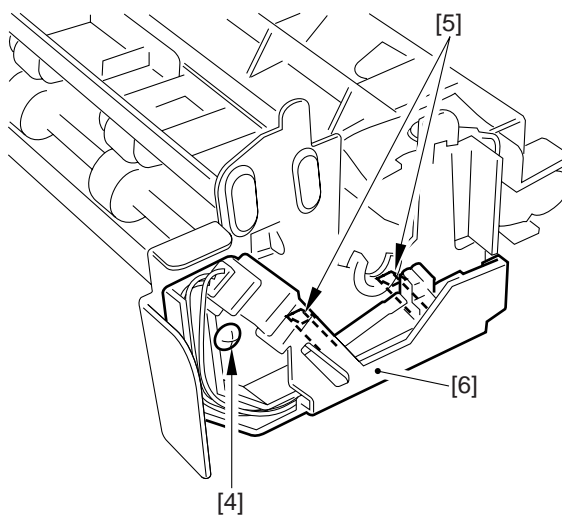

Figure 5-234

- 4) Remove the two bushings [7].

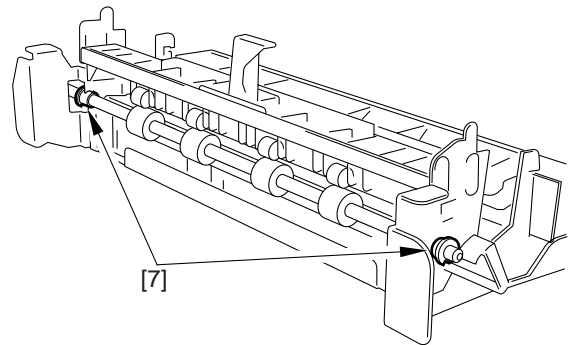

Figure 5-235

- 5) While shifting the delivery lower guide [8] toward the rear, detach the delivery roller [9].

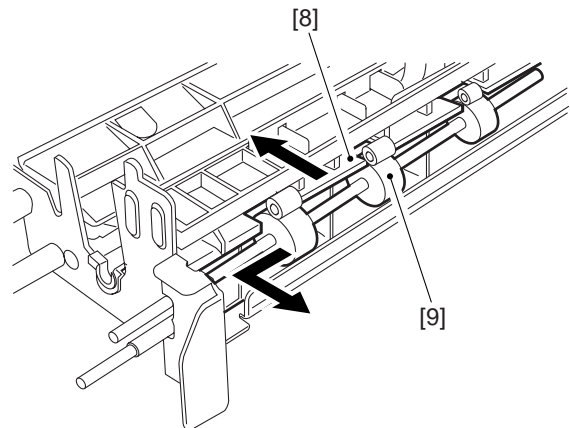

Figure 5-236





---

# CHAPTER 6

---

## FIXING SYSTEM

---

This chapter explains the principles used to fuse toner images to transfer medium in view of the functions of electrical and mechanical units and in relation to their timing of operation. It also shows how these units may be disassembled/assembled and adjusted.

I. OPERATIONS .....	6-1	II. DISASSEMBLY/ASSEMBLY .....	6-9
A. Outline .....	6-1	A. Fixing Assembly .....	6-10
B. Controlling the Fixing Temperature .....	6-3		



# I. OPERATIONS

## A. Outline

The major functions of the fixing unit are as follows:

Item	Description
Fixing method	SURF
Fixing drive	Main Motor (M1)
Fixing heater	Flat heater
Fixing temperature detection	Thermistor (TH1)
Cleaner	Cleaning roller
Protective functions	The following are used to detect and protect against an error; upon detection, power to the fixing heater will be cut: <ul style="list-style-type: none"> <li>• Thermistor (TH1)</li> <li>• Thermal fuse (FU2; activating at 228°C)</li> </ul>
Error code	E000 The fixing temperature fails to increase. E001 The thermistor has detected overheating. E002 Fault in fixing power control. E003 The fixing temperature has dropped abnormally.

**Table 6-101**

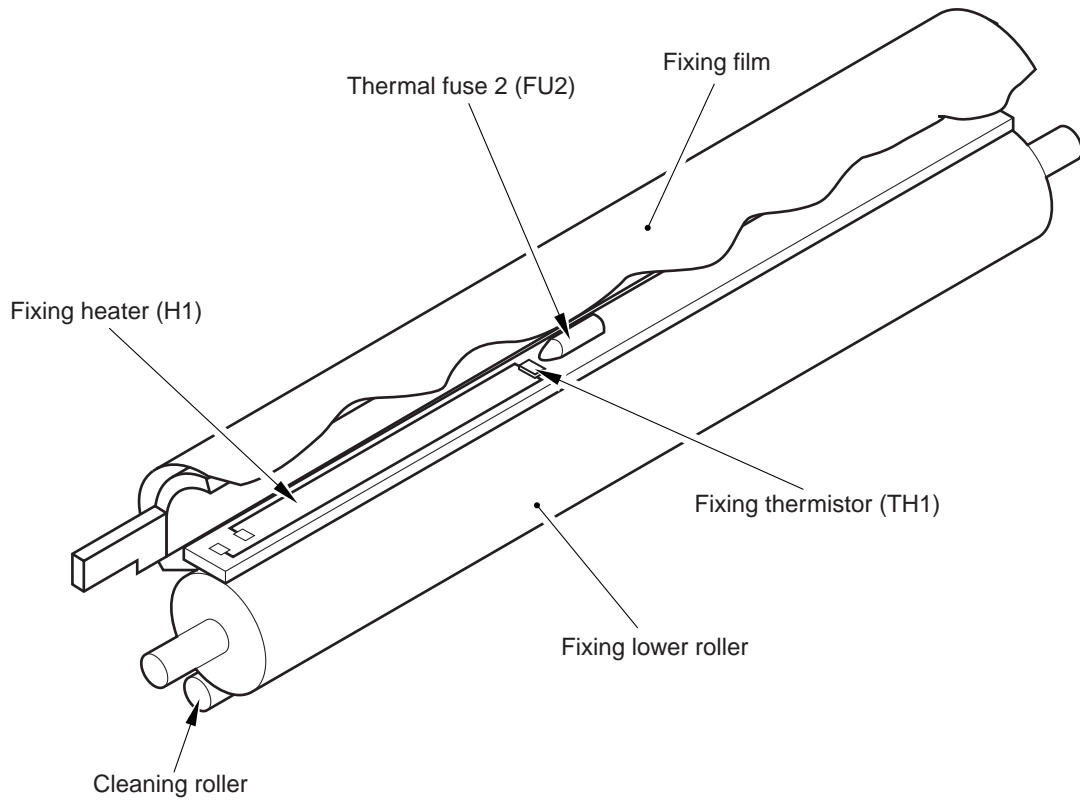

Figure 6-101

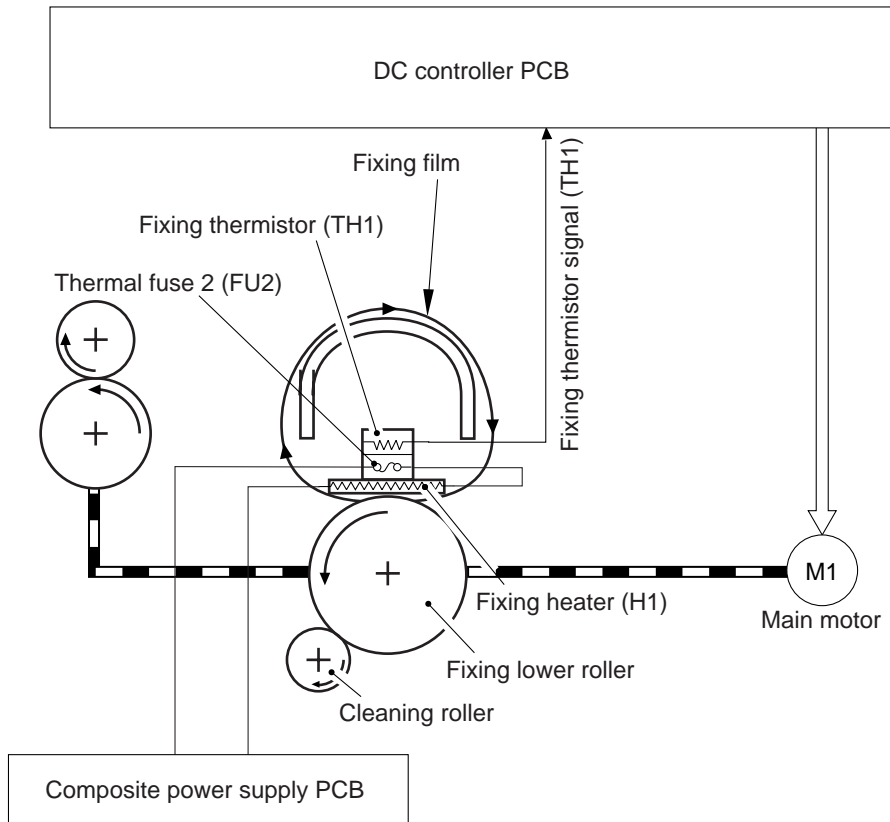

Figure 6-102

## B. Controlling the Fixing Temperature

### 1. Outline

The fixing lower roller of the fixing assembly is driven by the main motor (M1). When the fixing lower roller rotates, the film of the fixing upper unit starts to rotate in conjunction.

The fixing film is heated by the fixing heater (H1), which is a flat heater mounted in contact with the inner side of the film. The fixing heater is equipped with a thermistor (TH1), which sends the fixing thermistor signal (TH1) to the microprocessor (Q101) on the DC controller PCB; in response, the microprocessor controls the fixing heater duty signal (HEAT\_PWM) to vary the power supplied to the heater by way of controlling the temperature of the fixing heater.

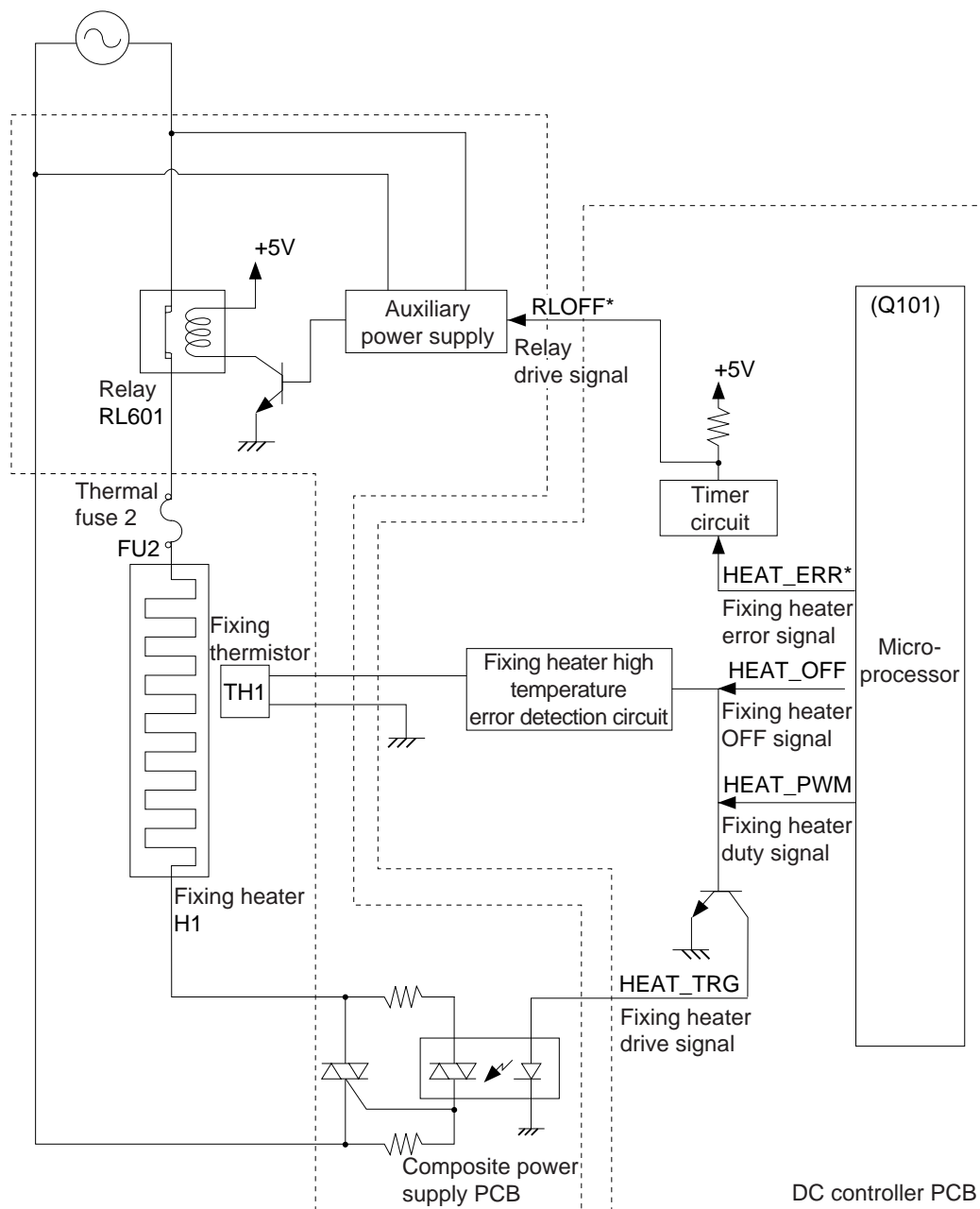

Figure 6-103

## 2. Controlling the Temperature of the Fixing Heater

The temperature of the fixing heater is switched according to the following two parameters:

- Temperature of the fixing heater when the Copy Start key is pressed.
- Number of copies to make in continuous copying mode

Table 6-102 shows the temperature of the fixing heater when the Copy Start key is pressed (as detected by the thermistor TH1) and the temperatures to which the fixing heater is controlled according to the number of copies made in continuous mode.

	Heater temperature when the Copy Start key is pressed	Number of copies	Control temperature (°C)
1	Less than 100°C	1	200
		2 ~ 9	195
		10 ~ 29	190
		30 ~ 39	185
		40 ~ 49	180
		50 ~ 59	175
		60 ~	170
2	100°C or more and less than 120°C	1 ~ 9	190
		10 ~ 19	186
		20 ~ 29	180
		30 ~ 39	175
		40 ~	170
3	120°C or more	1~ 9	180
		10~19	175
		20~	170

Table 6-102

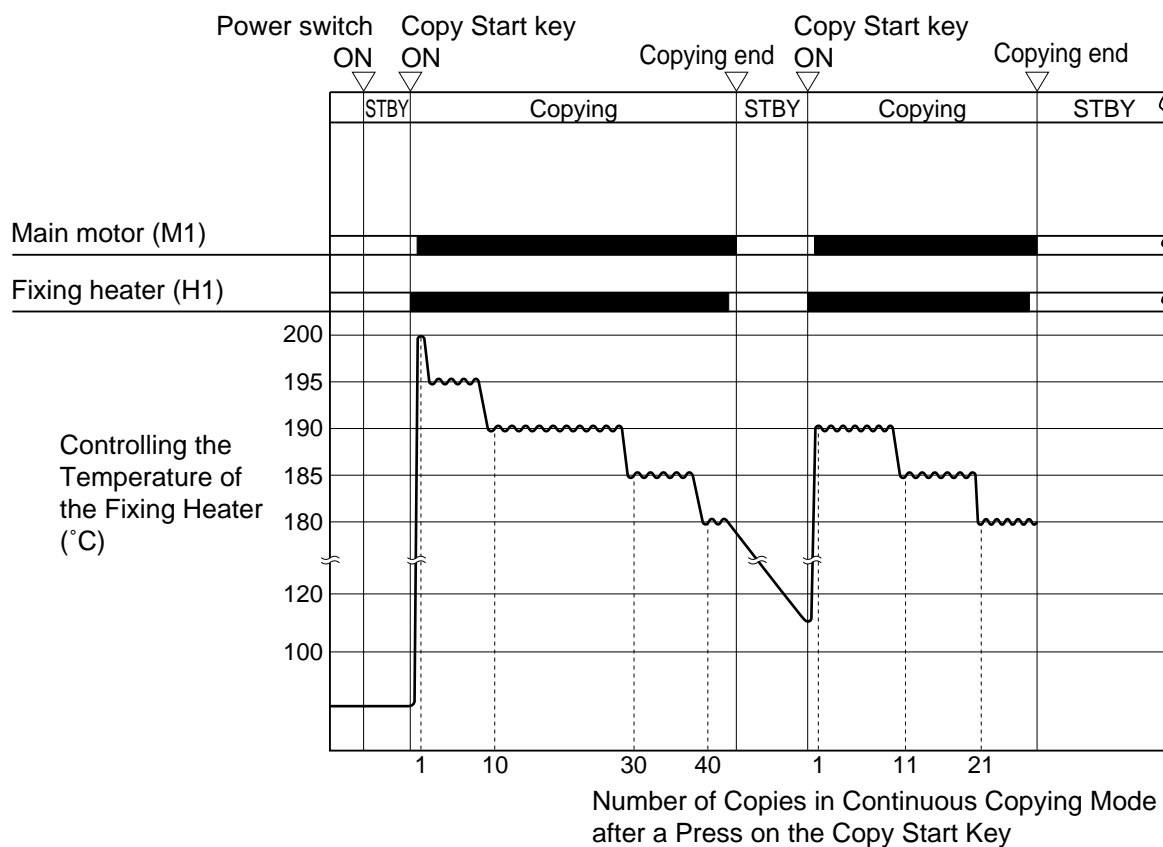

Figure 6-104

### 3. Controlling the Temperature Supplied to the Fixing Heater

The temperature of the fixing heater is controlled by controlling the power supplied to the fixing heater, and the power to the fixing heater is controlled using a phase control method.

The microprocessor on the DC controller PCB controls the timing at which the fixing heater duty signal (HEAT\_PWM) is generated so that power suited to the target temperature of the fixing heater may be supplied (phase control).

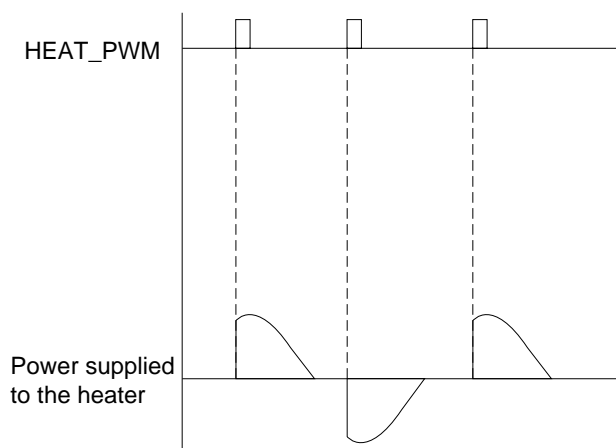

Figure 6-105

### 4. Correcting the Variation in the Resistance of the Fixing Heater

The characteristics of the flat heater used as the fixing heater vary from heater to heater because the production method. A discrepancy in resistance, if left alone, will not enable correct control of the fixing heater.

The machine makes correction in relation to the selected level of resistance (from three settings), and corrects it based on the readings obtained by the microprocessor.

**Caution:**

The level of resistance of the fixing heater is selected by an appropriate combination of the jumper wires connected to the connector of the fixing thermistor (TH1) and the delivery sensor (PS3).

The best level is selected at the factory when the fixing assembly is assembled. Do not change the combination of jumper wires.

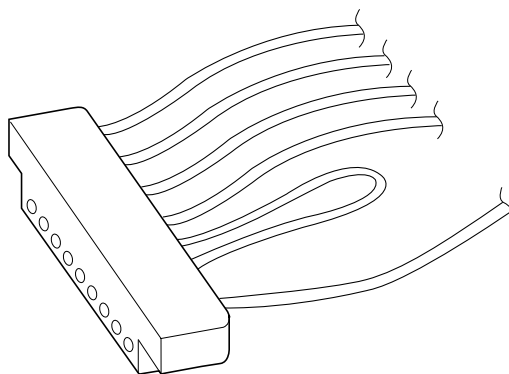

Figure 6-106



### 5. Controlling the Power Supplied to the Fixing Heater between Sheets

When the copying speed is controlled to 6 cpm to prevent overheating of the copyboard, the temperature of the fixing lower roller tends to increase because of the increased sheet-to-sheet distance. To prevent possible problems, power to the fixing heater is stopped between sheets when the copying speed is controlled to 6 cpm.

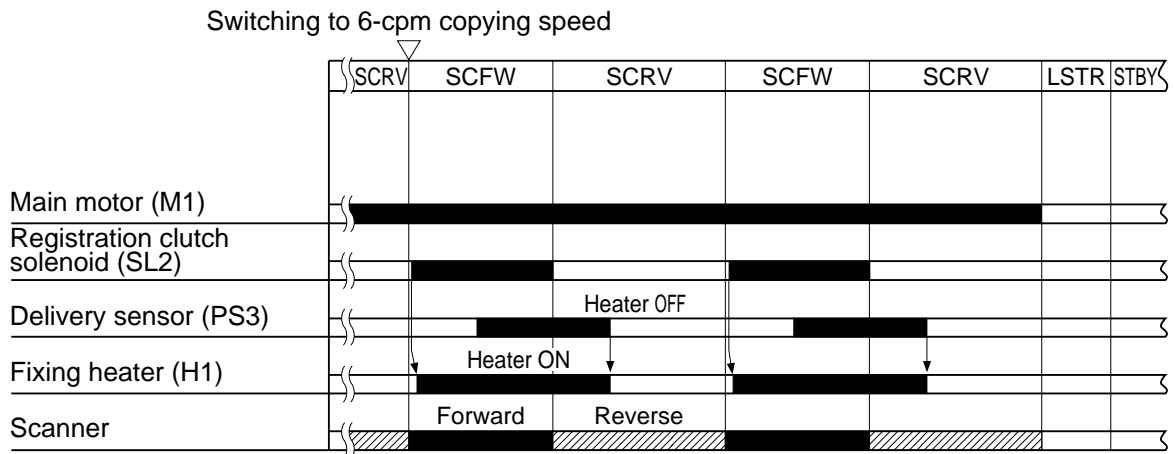

Figure 6-107

## 6. Protective Functions

The machine is equipped with the following protective functions to prevent malfunction of the fixing heater.

### a. Thermistor (TH1)

The microprocessor on the DC controller PCB monitors the voltage of the thermistor (TH1); if an abnormally high or low temperature is detected, the microprocessor sends the fixing heater error signal (HEAT\_ERR\*) to the timer circuit and, at the same time, indicate an error code (E000 through E003).

In response, the timer circuit sends the relay drive signal (RLOFF\*) to the auxiliary power supply in about 1.2 sec after it has received the fixing heater error signal (HEAT\_ERR\*).

The auxiliary power supply turns off the relay (RL601) to turn off the power. The data for problems associated with 'E000 through E003', i.e., related to the heater, is backed up and 'E000 through E003' will be indicated on the control panel next time the power is turned on.

When the power is turned off while 'E000' through 'E003' is indicated on the control panel, 'E000 through E003' will be indicated on the control panel if the power switch is turned on, and the Copy Start key will not be enabled.

### Related Error Code

#### E000

- The temperature detected by the thermistor (TH1) is not 65°C in 1.5 sec after the Copy Start key is pressed.
- The temperature detected by the thermistor (TH1) is not 150°C in 4 sec after the Copy Start key is pressed.

#### E001

- The temperature detected by the thermistor (TH1) is 230°C or more.
- The temperature detected by the thermistor (TH1) is higher than the control temperature by 30°C or more.
- The thermistor (TH1) has detected an increase in temperature of 100°C or more in 1 sec.
- The thermistor (TH1) has detected an increase in temperature of 40°C or more after it detected 100°C in standby state.

#### E002

The temperature detected by the thermistor (TH1) is 150°C or higher and, thereafter, maximum power has been supplied to the fixing heater for 10 to 14 sec during copying operation.

#### E003

The temperature detected by the thermistor (TH1) is 160°C and then 150°C or lower during copying operation.

### b. Thermal Fuse (FU2)

If the temperature around the thermal fuse exceeds 228°C and remains so for a specific period of time, the thermal fuse will blow to cut the power to the fixing heater.

## II. DISASSEMBLY/ASSEMBLY

As needed, disassemble/assemble the machine with the following in mind:

1. **▲** Before starting the work, turn off the power switch and disconnect the power plug for safety.
2. Unless otherwise instructed, assemble the parts by reversing the steps used to disassemble it.
3. Identify the screws by type (length, diameter) and location.
4. Use the washers where necessary. (The screws used to mount the grounding wire and Varistors come with a washer to ensure electrical continuity.)
5. As necessary, cut the harness band.
6. As a rule, do not operate the machine with any of its part removed.
7. A few of the screws used are special screws (with wider thread intervals). Do not use any screws indiscriminately.

## A. Fixing Assembly

### 1. Construction

Caution:

1. The fixing film is made from a special material. Do not touch it or subject it to dust.
2. The machine does not have a mechanism used to adjust the roller pressure.

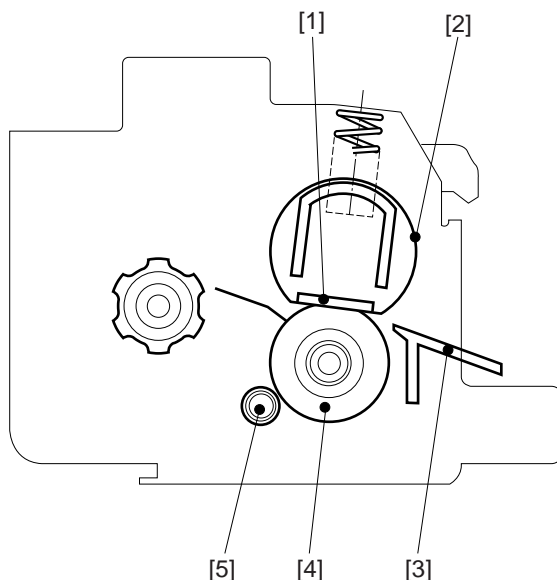

- |                   |                         |
|-------------------|-------------------------|
| [1] Fixing heater | [4] Fixing lower roller |
| [2] Fixing film   | [5] Cleaning roller     |
| [3] Inlet guide   |                         |

Figure 6-201

### 2. Removing the Fixing Assembly

- 1) Remove the front lower cover.  
(See Chapter 7.III.A.2. “Removing the Front Lower Cover.”)
- 2) Remove the screw [1], and free the two hooks [2]; then, detach the power supply cover [3].

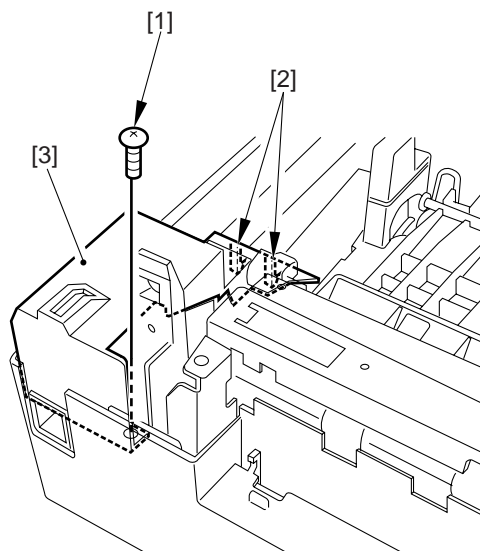

Figure 6-202

- 3) Remove the screw [4], and disconnect the connector [5].

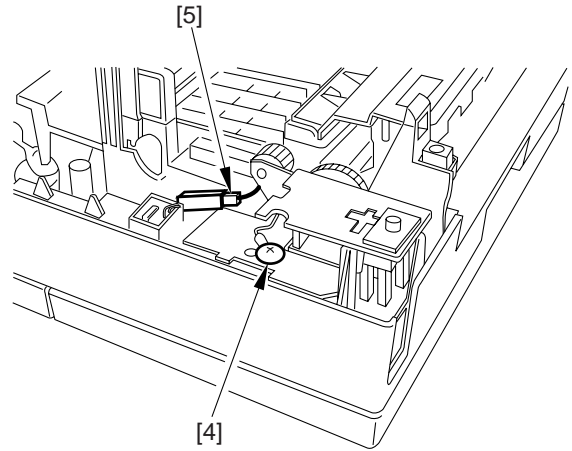

Figure 6-203

- 4) Remove the two screws [6], and disconnect the connector [7]; then, detach the fixing assembly [8] by turning it in the direction of the arrow.

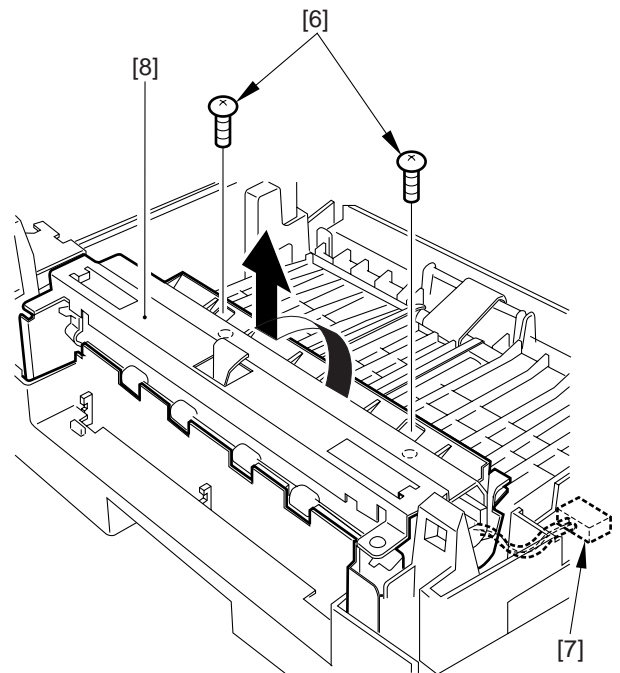
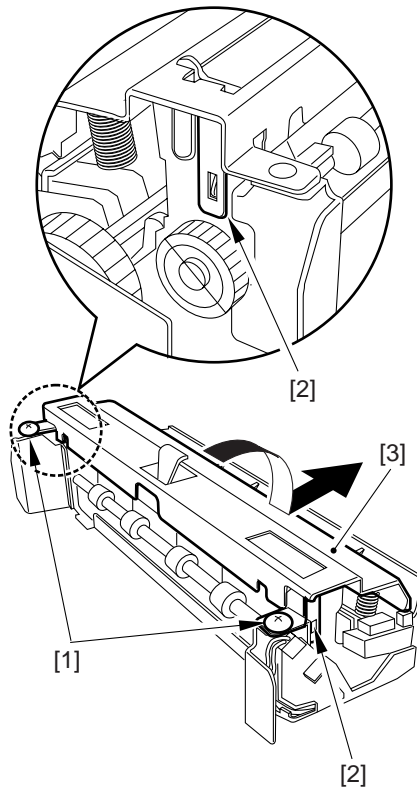

Figure 6-204

**3. Removing the Fixing Lower Roller**

- 1) Remove the fixing assembly.  
(See 2. “Removing the Fixing Assembly.”)
- 2) Remove the two screws [1], and free the two hooks [2]; then, detach the fixing upper stay [3] by turning it in the direction of the arrow.

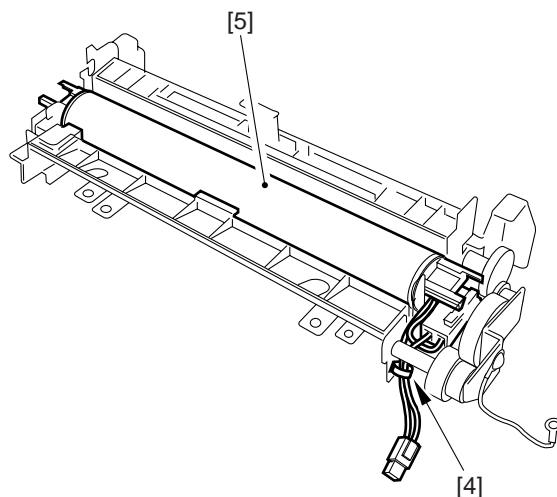

**Figure 6-205**

- 3) Detach the harness band [4] from the side plate, and remove the fixing upper unit [5].

**Caution:**

Do not disassemble the fixing film and the fixing heater. They cannot be replaced on their own.



**Figure 6-206**

- 4) Remove the fixing lower roller [6] together with the gear.

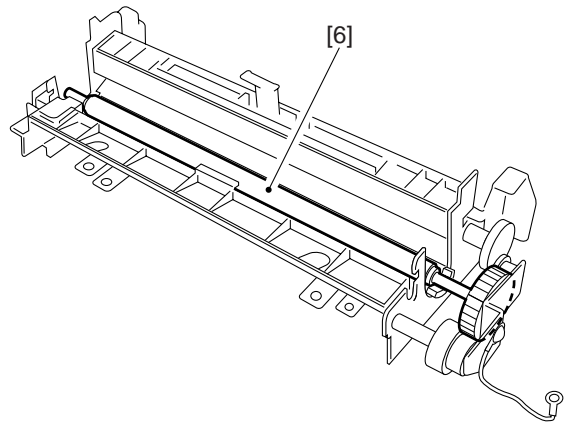

Figure 6-207

#### 4. Removing the Cleaning Roller

- 1) Remove the fixing lower roller.  
(See 3. "Removing the Fixing Lower Roller.")
- 2) Remove the cleaning roller [1] together with the bushing.

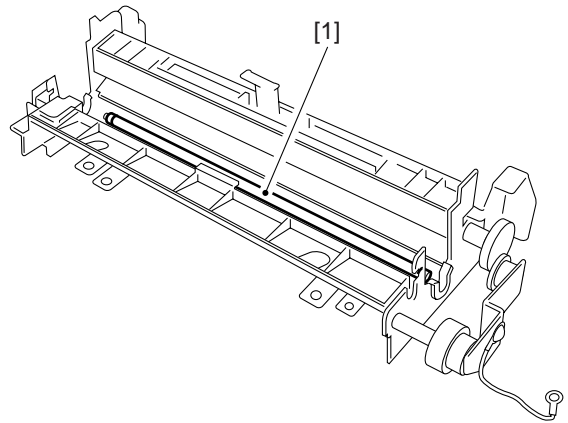

Figure 6-208





---

# CHAPTER 7

---

## EXTERNALS/AUXILIARY MECHANISMS

---

This chapter shows the machine's external parts, and explains the principles used for the machine's various control mechanisms in view of the functions of electrical and mechanical units and in relation to their timing of operation. It also shows how these units may be disassembled/assembled and adjusted.

I.	FANS .....	7-1	III.	DISASSEMBLY/ASSEMBLY .....	7-7
II.	POWER SUPPLY SYSTEM .....	7-3	A.	External Covers .....	7-8
A.	Outline of the Power Supply System .....	7-3	B.	Control Panel .....	7-15
B.	Power Supply Circuit .....	7-4	C.	Copyboard Glass .....	7-16
C.	Detecting an Error on the Composite Power Supply PCB .....	7-6	D.	Main Motor/Main Drive Assembly .....	7-17
D.	Protecting the Power Supply Circuit .....	7-6	E.	Electrical System .....	7-21



## I. FANS

The machine is equipped with two fans serving to discharge ozone or cool its inside.

The heat exhaust fan is driven directly by the main motor (M1; through a belt and a gear), and is designed to rotate at all times while the main motor is rotating.

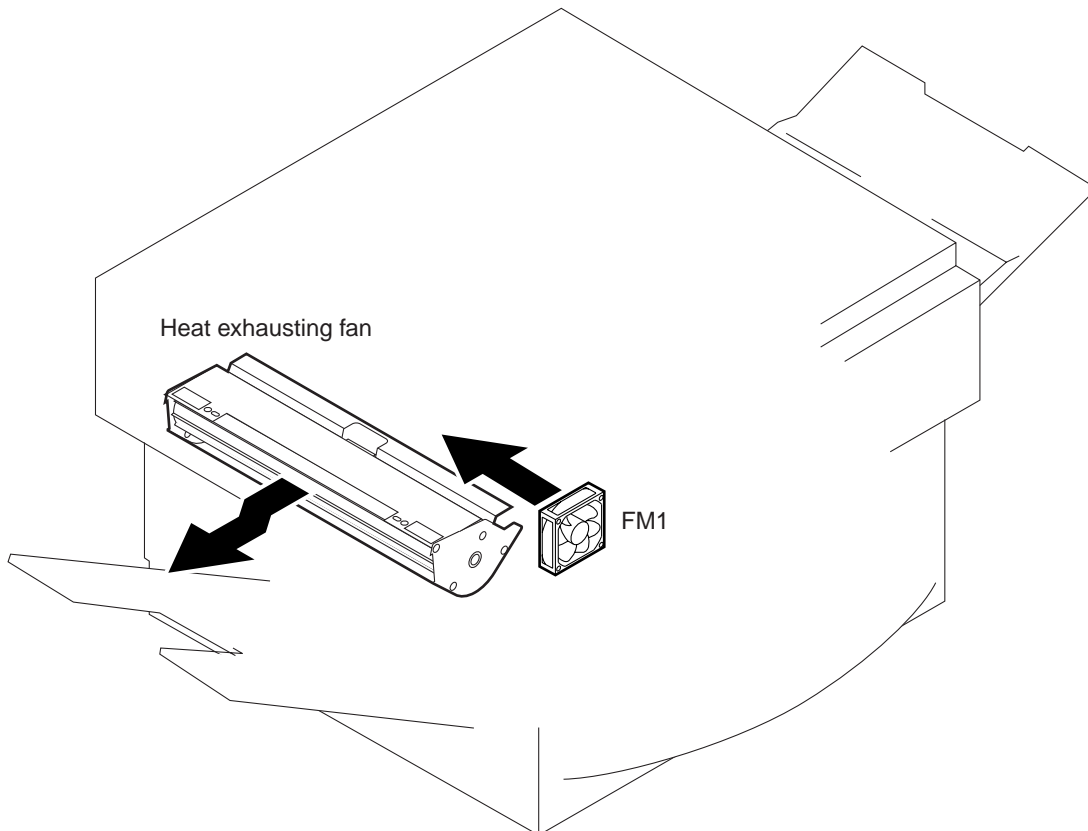
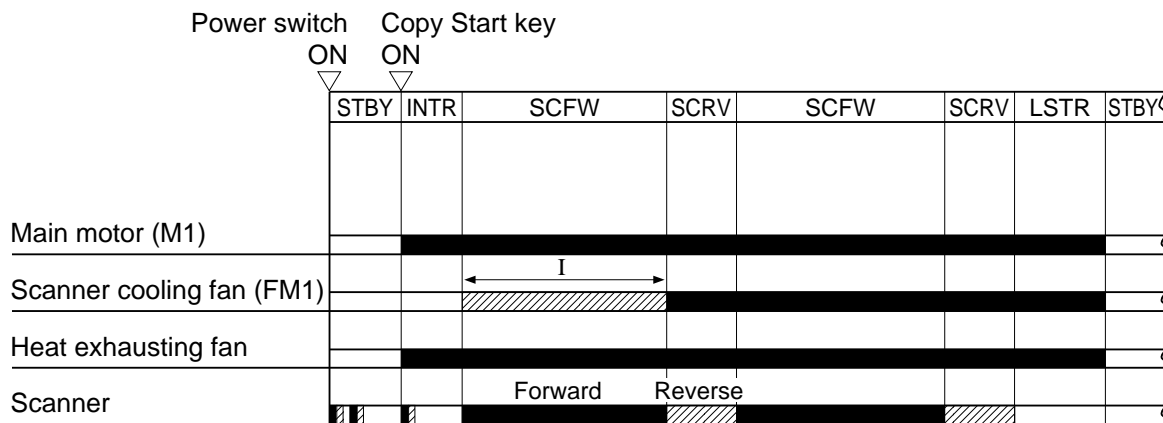

Figure 7-101

The scanner cooling fan (FM1) is turned on and off according to the temperature detected by the scanner thermistor (TH2).

If the reading by the thermistor is 37.5°C or higher and the copying speed reaches 6 cpm, the fan starts to rotate. If the reading is lower than 37.5°C, on the other hand, the fan will not rotate if no more than one copy is made or while making the first copy of a continuous copying job. (It rotates when making the second and subsequent copies of a continuous copying job.)



I: If 6-cpm copying speed control is executed starting with the first copy, the fan will rotate.

Figure 7-102

## II. POWER SUPPLY SYSTEM

### A. Outline of the Power Supply System

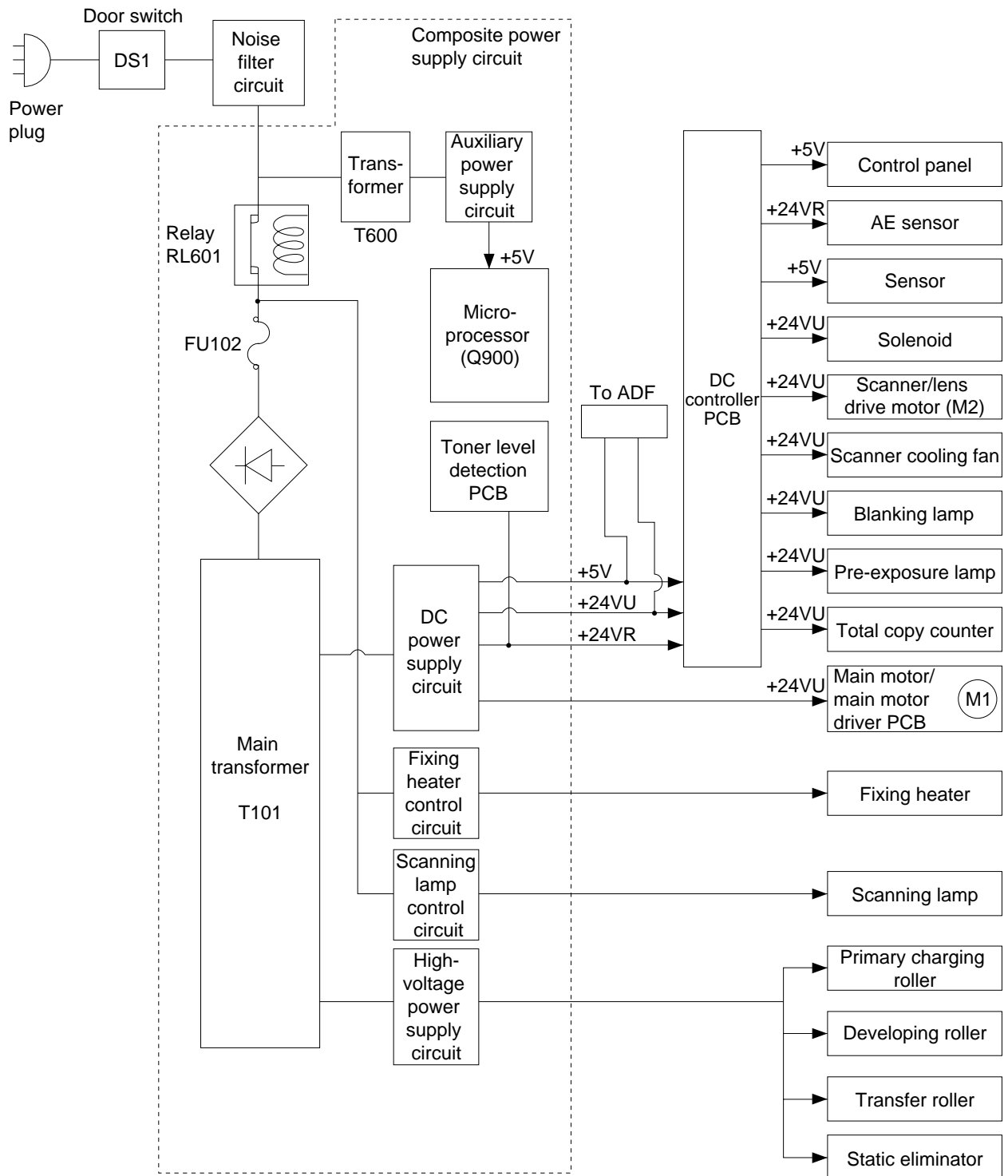

Figure 7-201

## B. Power Supply Circuit

The machine's power supply consists of a composite power supply circuit in which a DC power supply, scanning lamp power supply, and high-voltage power supply are integrated on a single board. It also possesses a microprocessor for exchanges of various data with the machine's DC controller PCB.

The machine's power switch is a soft switch, and the machine is equipped with an auxiliary power supply used to operate the switch. The auxiliary power supply provides the microprocessor (Q900) with +5 V as long as the door switch (DS1) remains on.

AC power is supplied to the DC power supply when the power switch on the control panel is turned on. In response, the DC power supply provides the DC controller PCB with +5 V, +24 VR, and +24 VU.

When the power switch is turned off, power to the DC controller PCB is cut; to back up data on error codes (E000, E001, E002, E003), the machine uses a lithium battery (BAT1) located within the DC controller circuit; using the battery, the appropriate error information will be indicated on the control panel when the power is returned, informing the presence of an error associated with the fixing heater.

### Caution:

Replace the lithium battery only with the one listed in the Parts Catalog. Use of a different battery may present a risk of fire or explosion. The battery may present a fire or chemical burn hazard if mistreated. Do not recharge, disassemble, or dispose of it in fire. Keep the battery out of reach of children and discard any used battery promptly.

### Reference:

The tolerances in DC voltage are as follows:

- +5 V  $\pm 5\%$
- +24 VR  $\pm 5\%$
- +24 VU -10.0%, +12.5%

For +24 VR, two types of voltage are used:

- During copying, +24 V  $\pm 5\%$
- During standby, +18 V  $\pm 10\%$

However, the above assume that the deviations in AC input are -15%, +10%.

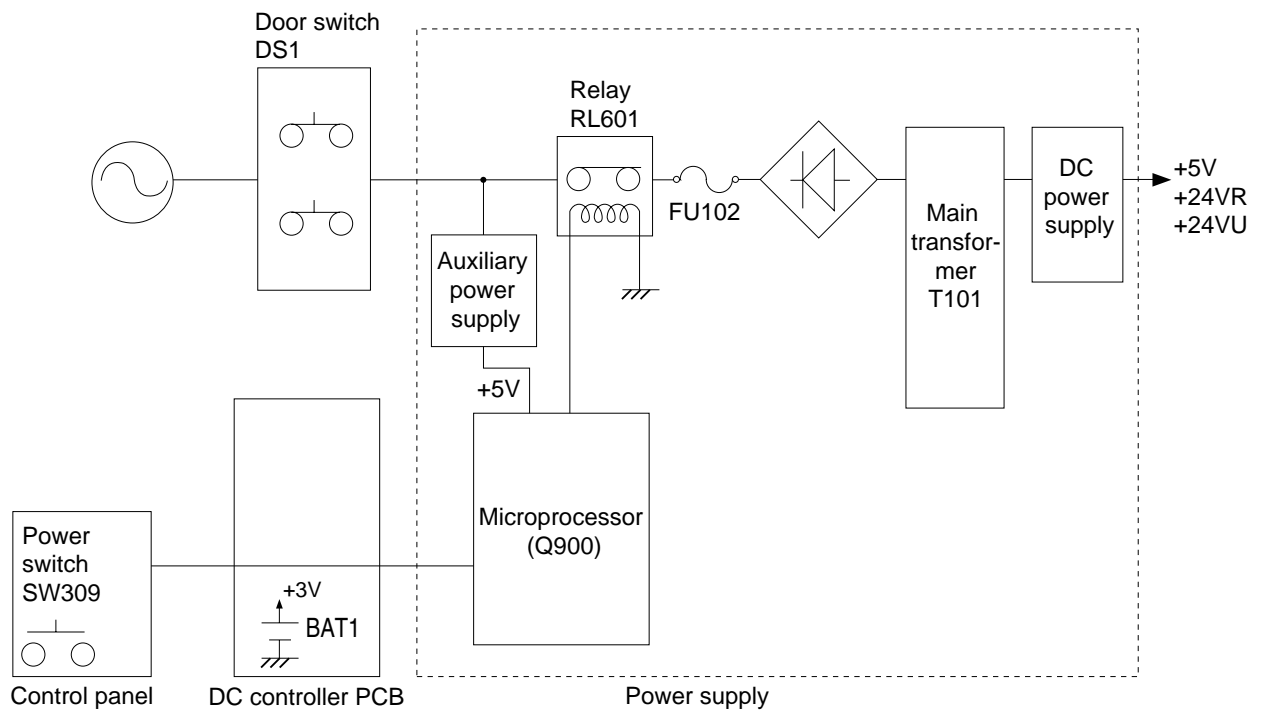

Figure 7-202

## C. Detecting an Error on the Composite Power Supply PCB

The machine's composite power supply PCB is equipped with a self diagnostic function to check each power output and the communication with the DC controller PCB using the microprocessor (Q900) mounted on it.

If any of the following errors occurs, the microprocessor will exchange signals with the DC controller PCB, and will indicate the result of self diagnosis on the control panel.

### 1. Detecting an Over-Current in the Low-Voltage System

If an over-current is detected because of a fault in a DC load, the composite power supply PCB will turn off the relay (RL601) to cut the AC input.

### 2. Detecting a Fault in the High-Voltage Control Value

If a deviation is found between the setting value and the actual value is detected in any of the following voltages, the composite power supply will indicate 'E064' on the control panel.

- Primary charging DC bias
- Developing DC bias
- Transfer bias

### 3. Detecting a Fault in the Low-Voltage Control Value

If a deviation is detected between the setting value and the actual control value in +24 V (DC output), the composite power supply PCB will indicate 'E803' on the control panel.

### 4. Fault in the Communication with the DC Controller

If the DC controller PCB detects a fault in the communication with the composite power supply PCB, 'E240' will be indicated on the control panel for about 4 sec, and then the relay (RL601) will be turned off to cut the AC input.

## D. Protecting the Power Supply Circuit

The composite power supply PCB is equipped with an over-current detection function which turns on a protective mechanism to stop output if a load suffers a short-circuit.

If the output has stopped, it may be reset by opening the machine's top unit, correcting the load, and then turning the power switch back on.

Keep in mind, however, that repeated short-circuiting and resetting can blow the fuse (FU102).



### III. DISASSEMBLY/ASSEMBLY

As needed, disassemble/assemble the machine with the following in mind:

1. **▲** Before starting the work, turn off the power switch and disconnect the power plug for safety.
2. Unless otherwise instructed, assemble the parts by reversing the steps used to disassemble it.
3. Identify the screws by type (length, diameter) and location.
4. Use the washers where necessary. (The screws used to mount the grounding wire and Varistors come with a washer to ensure electrical continuity.)
5. As necessary, cut the harness band.
6. As a rule, do not operate the machine with any of its part removed.
7. A few of the screws used are special screws (with wider thread intervals). Do not use any screws indiscriminately.

## A. External Covers

For instructions on how to remove the ADF, see Chapter 8.

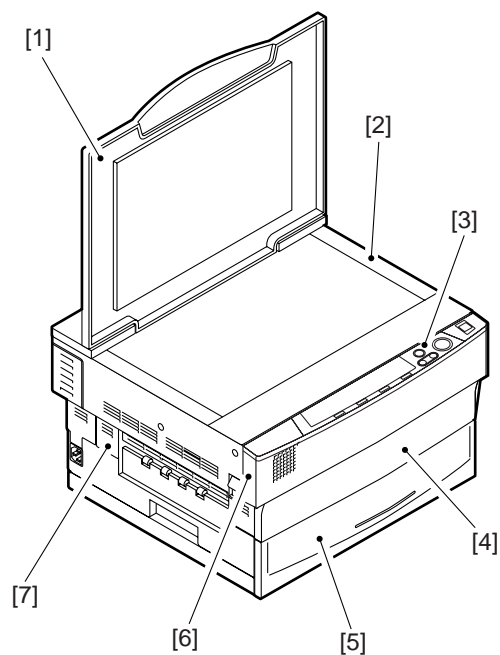

- |                       |                       |
|-----------------------|-----------------------|
| [1] Copyboard cover   | [5] Cassette          |
| [2] Top cover         | [6] Front upper cover |
| [3] Control panel     | [7] Left cover        |
| [4] Front lower cover |                       |

**Figure 7-301 (Copyboard type)**

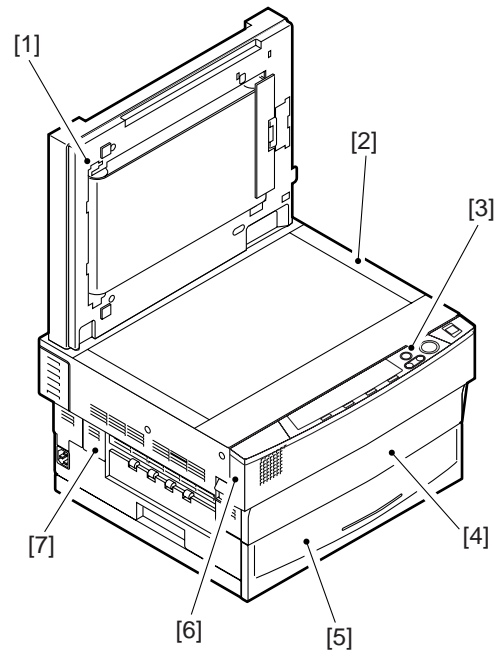

- |                       |                       |
|-----------------------|-----------------------|
| [1] ADF               | [5] Cassette          |
| [2] Top cover         | [6] Front upper cover |
| [3] Control panel     | [7] Left cover        |
| [4] Front lower cover |                       |

**Figure 7-302 (ADF type)**

**Note:**

Remove the covers as necessary when cleaning, inspecting, or repairing the inside of the machine.

Those covers that may be detached from their own by mere removal of mounting screws are omitted from the discussions.

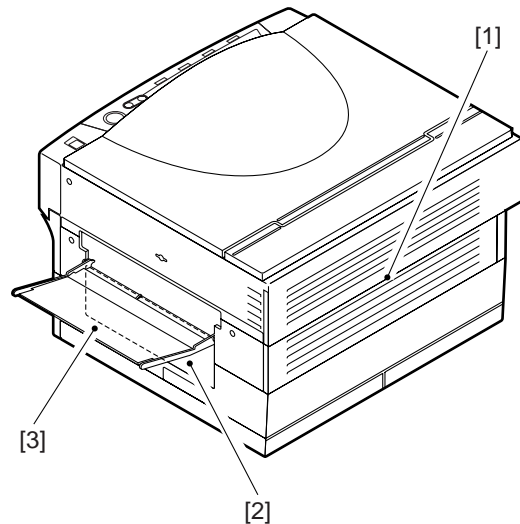

- |                      |
|----------------------|
| [1] Rear cover       |
| [2] Right door       |
| [3] Multifeeder unit |

**Figure 7-303**

**1. Removing the Top Cover**

- 1) Remove the copyboard cover or the ADF.
- 2) Open the machine's top unit.
- 3) Remove the two screws [1], and detach the front upper cover [2].

**Caution:**

A flexible cable for the control panel is connected to the front upper cover. Disconnect the cable from the DC controller.

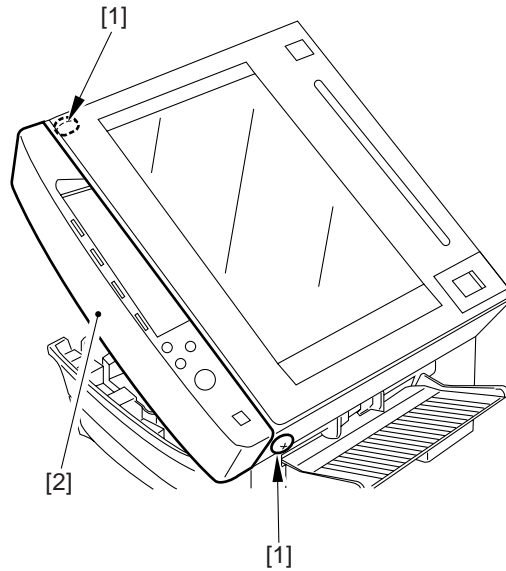

**Figure 7-304**

- 4) Free the two claws [3], and slide the left cover [4] to detach.

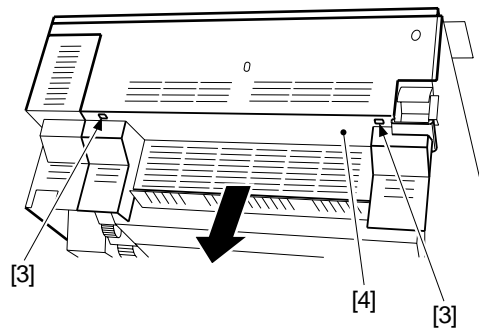

**Figure 7-305**

- 5) Remove the screw [5], and free the four claws [6]; then, detach the rear cover [7].

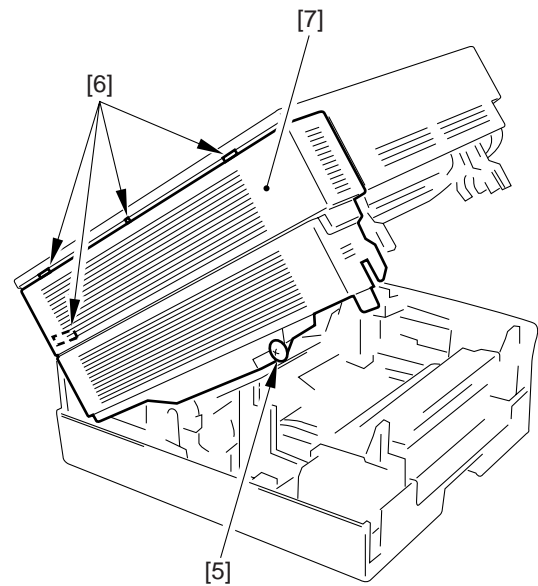

Figure 7-306

- 6) Remove the screw [8], and detach the copyboard cover foot retainer [9].

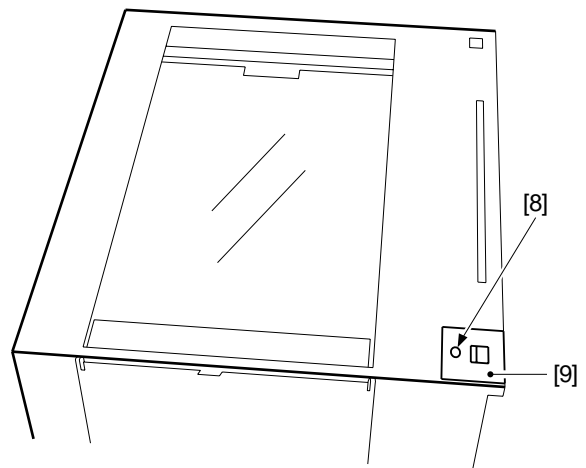

Figure 7-307

- 7) Free the two claw [10]; then, lift the top cover [11] to detach.

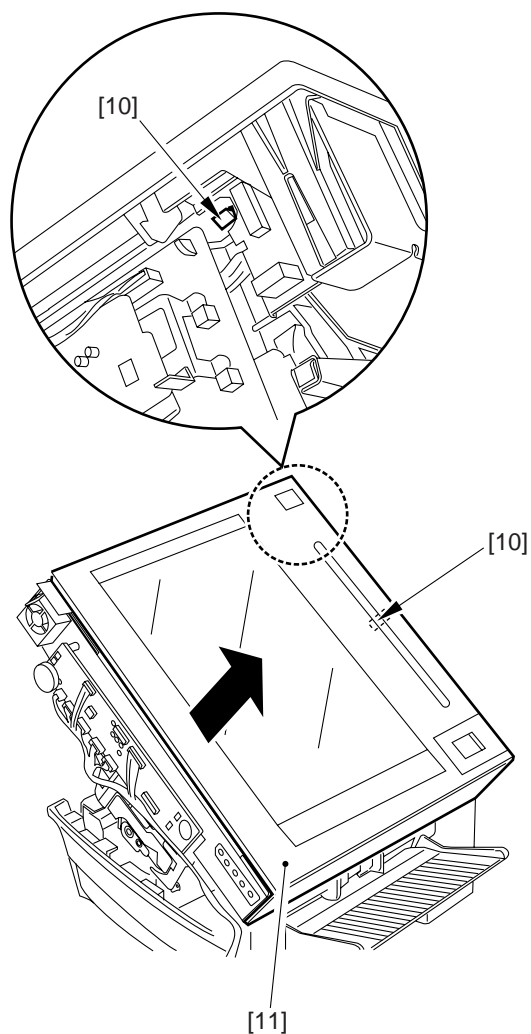
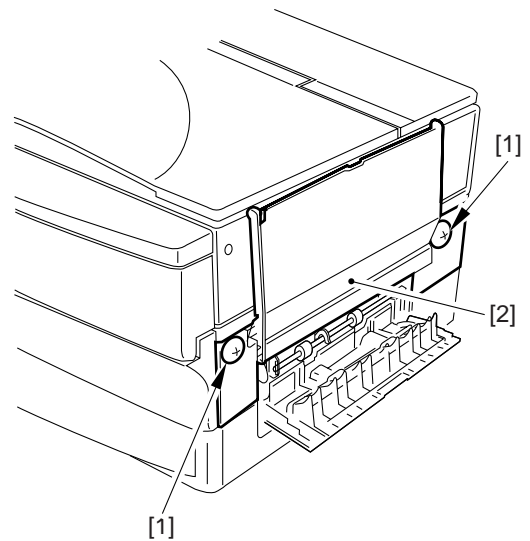

Figure 7-308

**2. Removing the Front Lower Cover**

- 1) Open the right door.
- 2) Remove the two screws [1], and detach the multifeeder unit [2].

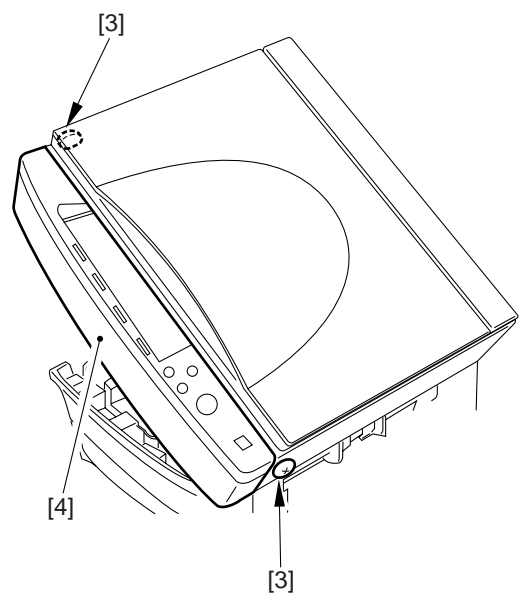

**Figure 7-309**

- 3) Open the machine's top unit.
- 4) Remove the two screws [3], and detach the front upper cover [4].

**Caution:**

A flexible cable for the control panel is connected to the front upper cover. Disconnect the cable from the DC controller.



**Figure 7-310**

- 5) Remove the two screws [5] from the screw plate found at the bottom of the machine.

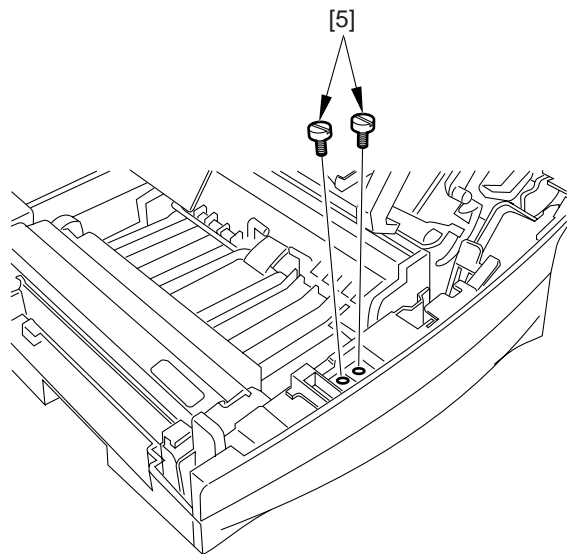

Figure 7-311

- 6) While freeing the five claws [6], detach the front lower cover [7].

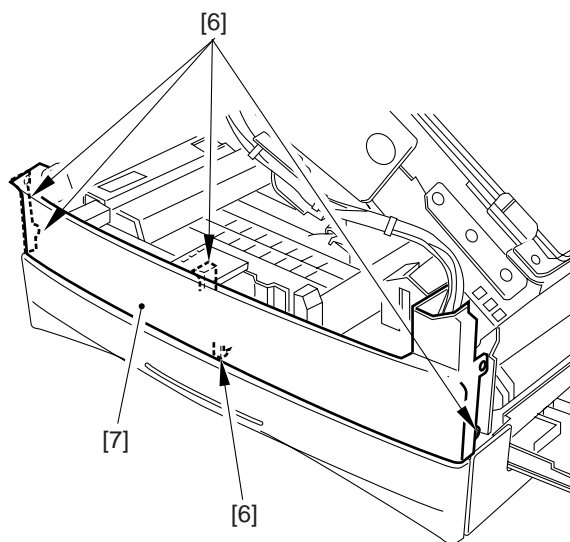

Figure 7-312

**Caution:**

When mounting the multifeder unit, be sure to perform the following first:

- 1) Turn on the power switch; then, select the multifeder as the source of paper, and press the Copy Start key.
- 2) When the pickup gear unit assembly has moved to its upper limit, turn off the power switch.
- 3) Mount the multifeder, and make one copy using it as the source of paper.

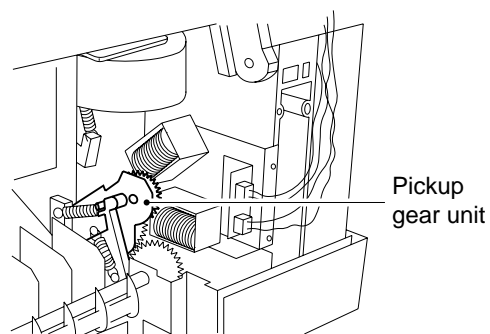

Figure 7-313



## B. Control Panel

### 1. Removing the Control Panel

- 1) Open the machine's top unit.
- 2) Remove the two screws [1], and detach the front upper cover [2].

**Caution:**

A flexible cable for the control panel is connected to the front upper cover. Disconnect the cable from the DC controller.

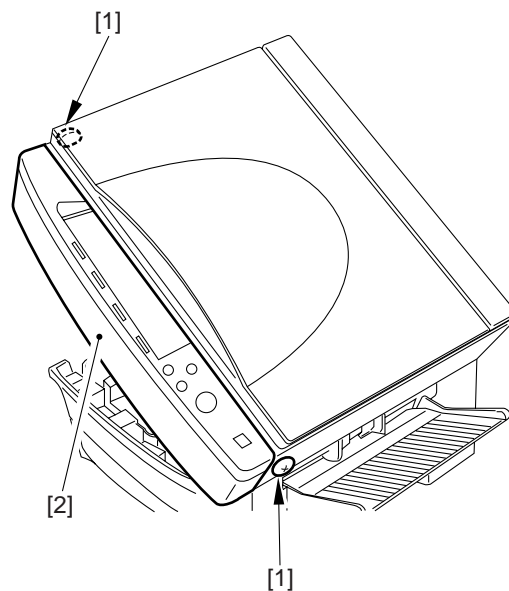

Figure 7-314

- 3) Remove the two screws [3], and free the eight claws [4]; then, detach the control panel [5].

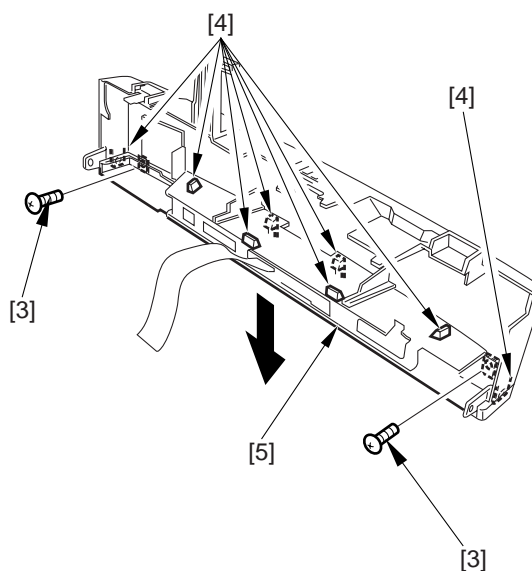

Figure 7-315

## C. Copyboard Glass

### 1. Removing the Copyboard Glass

- 1) Remove the top cover.  
(See A.1. "Removing the Top Cover.")
- 2) Close the machine's top unit.
- 3) Remove the two screws [1], and detach the two support plates [2]; then, detach the copyboard glass [3].

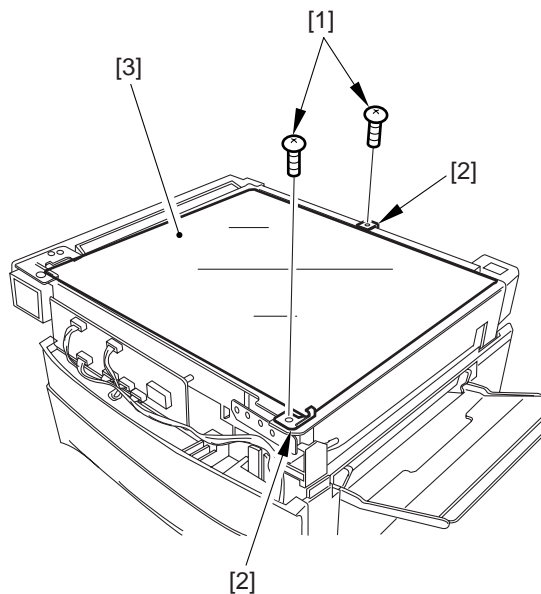

Figure 7-316

**Note:**

When mounting the copyboard glass, be sure that the grounding plate is on the side of its top edge. (ADF type only)

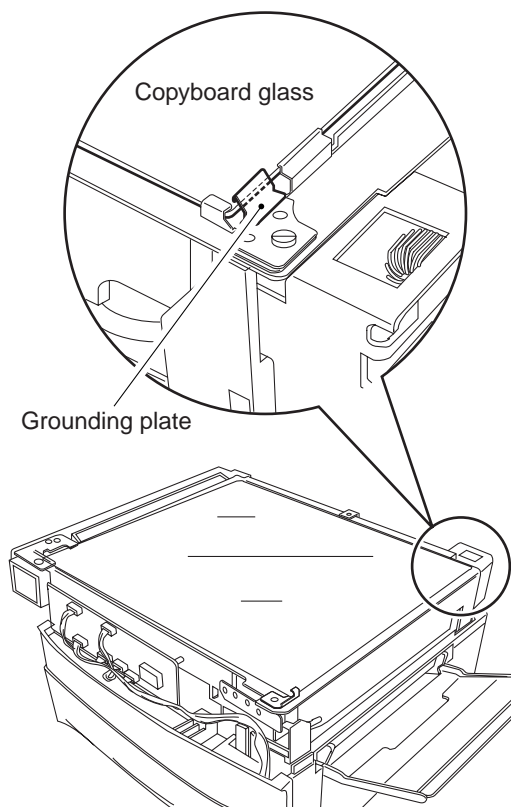

Figure 7-317

## D. Main Motor/Main Drive Assembly

### 1. Removing the Main Motor Unit

- 1) Remove the drum unit.
- 2) Remove the composite power supply PCB.  
(See E.2. "Removing the Composite Power Supply PCB.")
- 3) Remove the screw [1], and detach the high-voltage PCB [2].

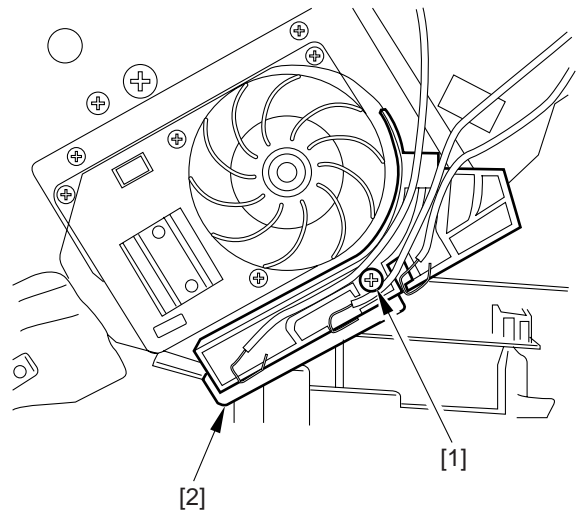

Figure 7-318

- 4) Remove the insulating sheet [3].

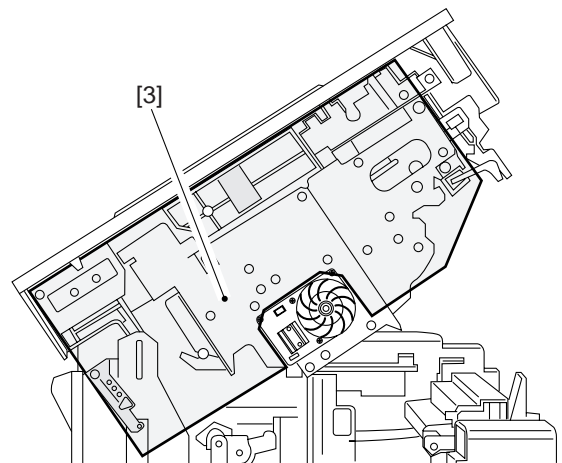

Figure 7-319

- 5) Detach the fan belt [4].

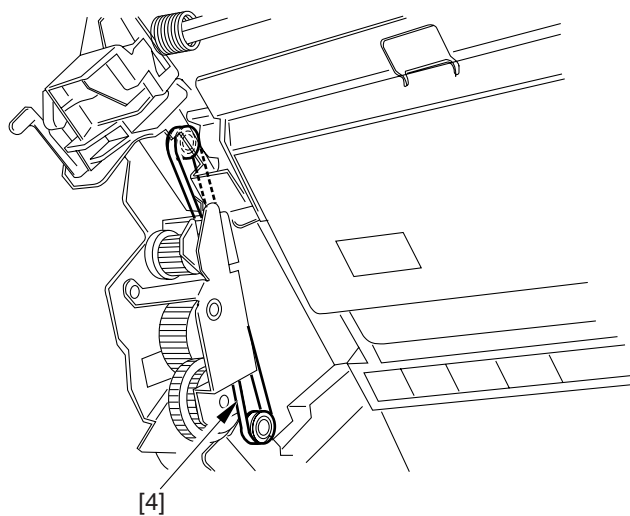

Figure 7-320

- 6) Remove the four screws [5], and detach the main motor unit [6].

**Caution:**

When installing the main motor unit, be sure to attach the fan belt.  
After attaching the fan belt, make sure that the belt is free of twists.

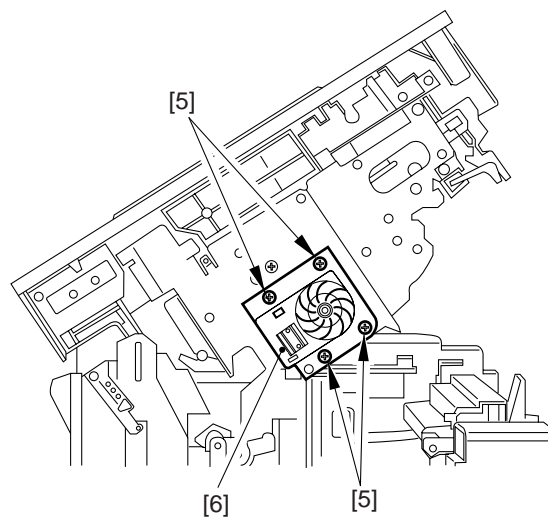

Figure 7-321

## 2. Removing the Main Drive Assembly

- 1) Remove the drum unit.
- 2) Remove the composite power supply PCB. (See E.2. "Removing the Composite Power Supply PCB.")
- 3) Remove the screw [1], and detach the high-voltage PCB [2].

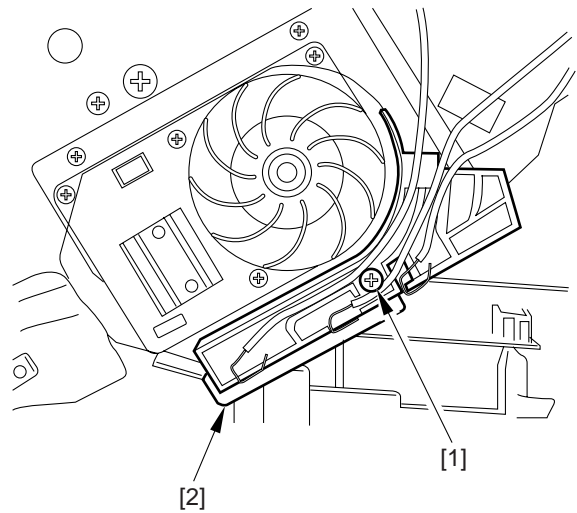

Figure 7-322

- 4) Remove the insulating sheet [3].

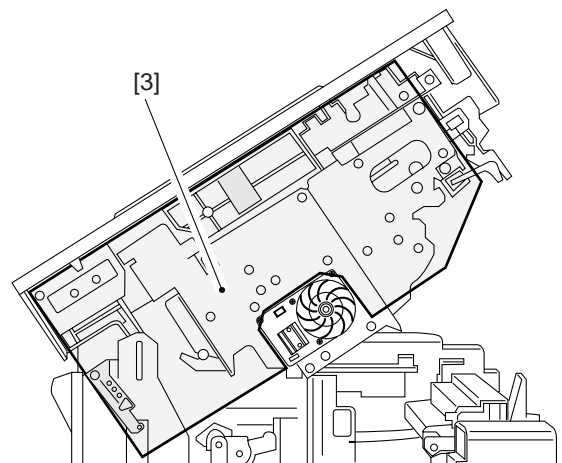

Figure 7-323

- 5) Detach the fan belt [4].

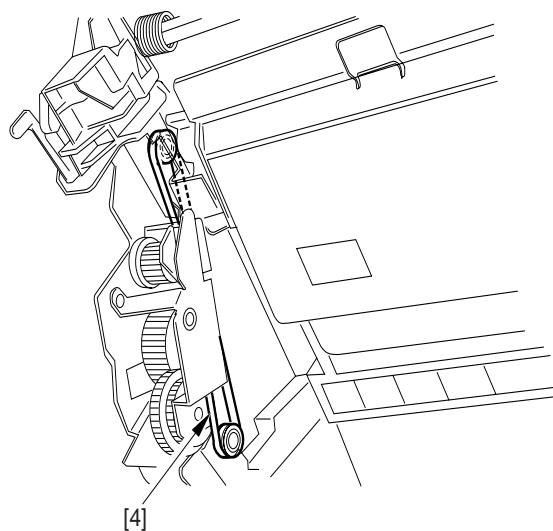

Figure 7-324

- 6) Remove the four screws [5], and detach the main drive assembly [6].

**Caution:**

When installing the main drive assembly, be sure to attach the fan belt. After attaching the fan belt, make sure that the belt is free of twists.

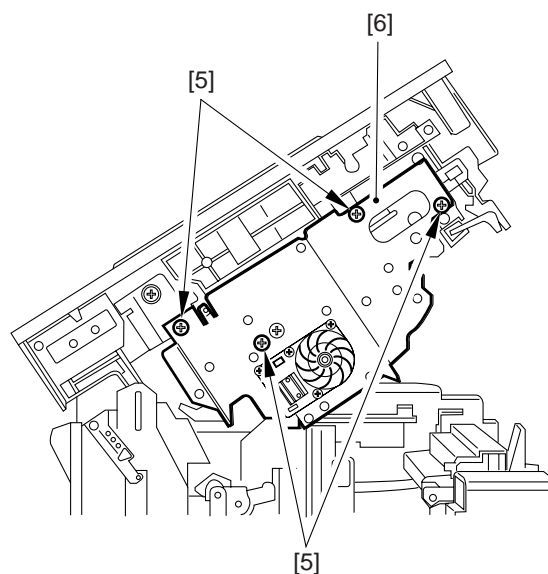

Figure 7-325

## E. Electrical System

### 1. Removing the DC Controller PCB

- 1) Open the machine's top unit.
- 2) Remove the screw [1], and detach the front upper cover [2].

#### Caution:

The flexible cable for the control panel is connected to the upper front cover; disconnect the cable from the DC controller PCB.

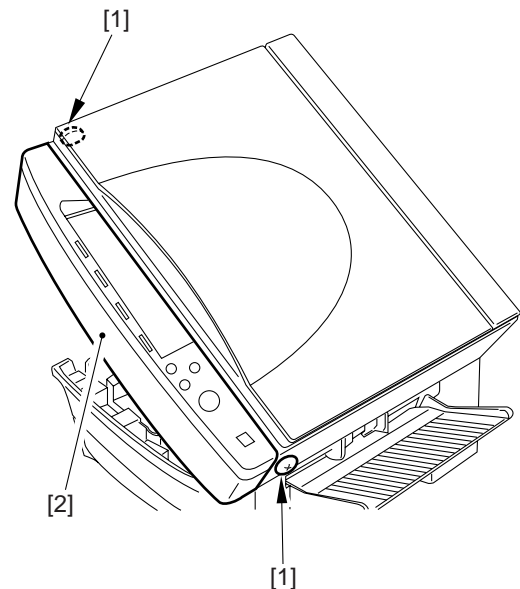

Figure 7-326

- 3) Disconnect all connectors from the DC controller PCB, remove the screw [3], and free the five claws [4]; then, detach the DC controller PCB [5].

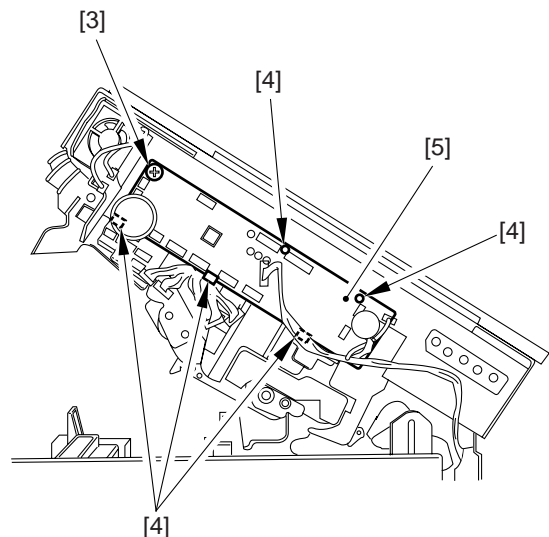

Figure 7-327

## 2. Removing the Composite Power Supply PCB

- 1) Remove the copyboard cover or the ADF.
- 2) Remove the left cover and the rear cover.
- 3) Remove the screw [1], and remove the copyboard cover foot retainer [2].

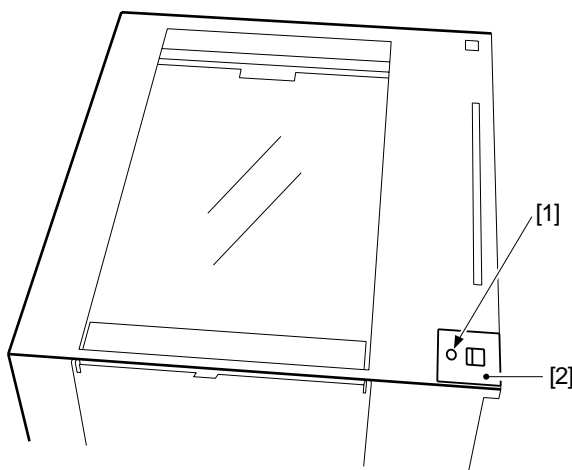

Figure 7-328

- 4) Disconnect the eleven connectors [3] from the composite power supply PCB, and disconnect the connector [4] from the main motor assembly.

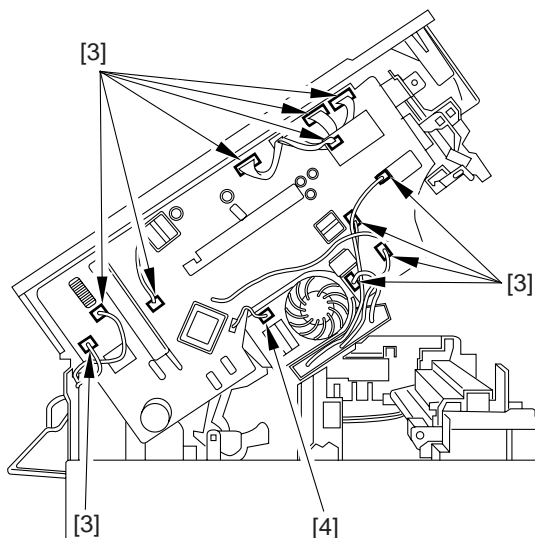

Figure 7-329



- 5) Remove the seven screws [5], and free the five claws [6]; then, detach the composite power supply PCB [7].

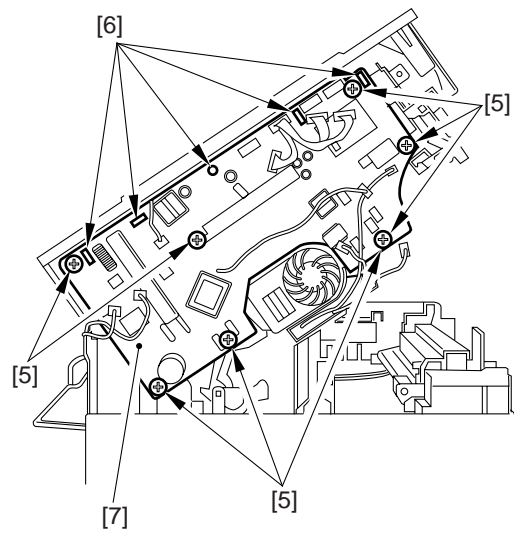

Figure 7-330

### 3. Points to Note When Handling the Composite Power Supply PCB

- 1) Some capacitors on the composite power supply hold charges when the machine's power supply is off.  
Take extra care never to short the terminals of the capacitor whenever you have removed the composite power supply PCB.
- 2) When handling the PCB, hold its heat radiating plate (at the center) or its both edges. In particular, keep in mind that holding the area indicated by "⊘" can cause deformation or cracking of the board.

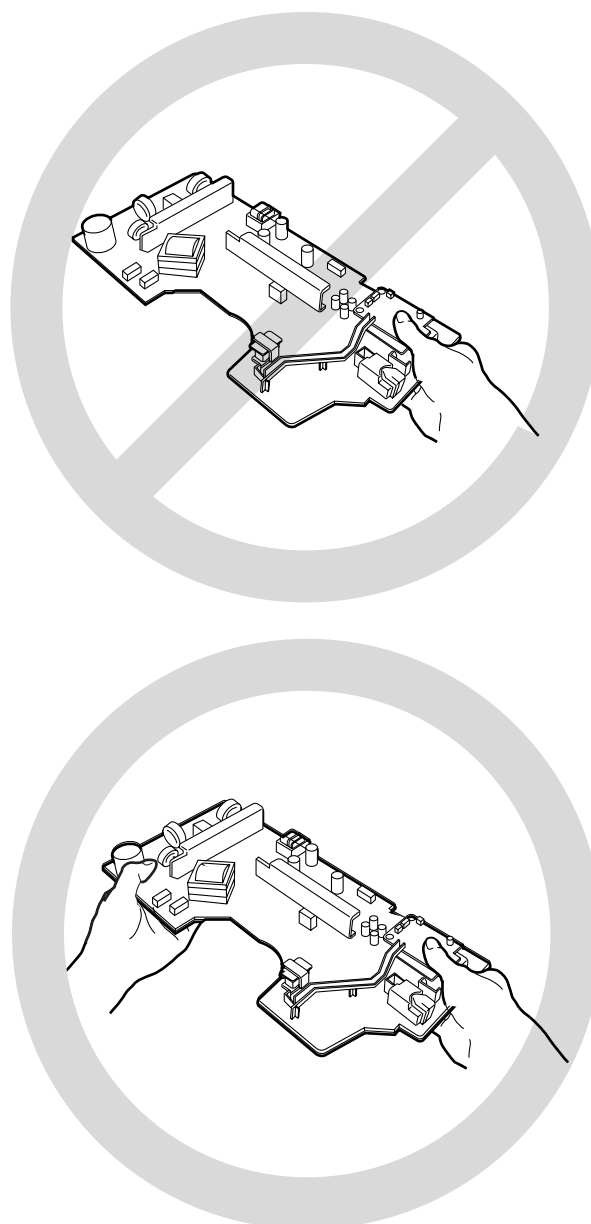
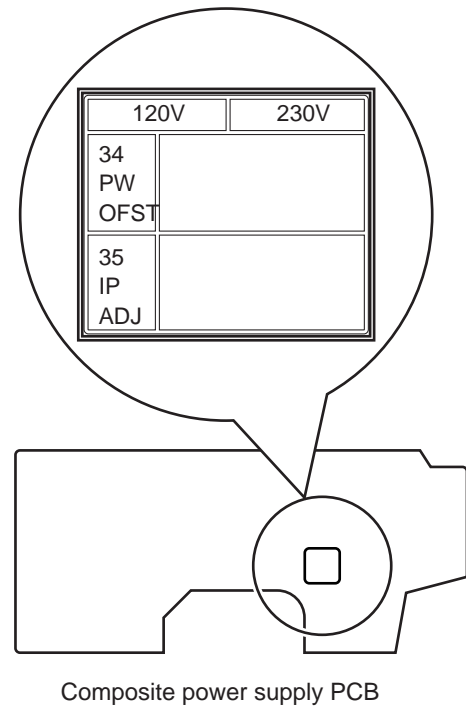

Figure 7-331

#### 4. After Replacing the Composite Power Supply PCB

- 1) If you have replaced the composite power supply PCB, be sure to enter the values indicated on the PCB to '34' and '35' in service mode.



**Figure 7-332**



---

# CHAPTER 8

---

## ADF

---

I.	ADF .....	8-1	H.	Controlling the Belt Motor ..	8-15
A.	Outline .....	8-1	I.	Detecting Original Jams .....	8-16
B.	Basic Construction .....	8-2	J.	Power Supply .....	8-17
C.	Basic Operations .....	8-4	II.	DISASSEMBLY/ASSEMBLY .....	8-18
D.	Detecting an Original .....	8-6	A.	Removing the ADF .....	8-19
E.	Pickup Operation .....	8-8	B.	External Covers .....	8-21
F.	Delivery .....	8-12	C.	Drive System .....	8-23
G.	Controlling the Pickup Motor .....	8-14	D.	Feeding System .....	8-26
			E.	Electrical System .....	8-33



## I. ADF

### A. Outline

The ADF picks up the originals stacked on the original tray starting with the topmost original, moves them through the copyboard, and delivers them.

See Figure 8-101 for an outline of the feeding route.

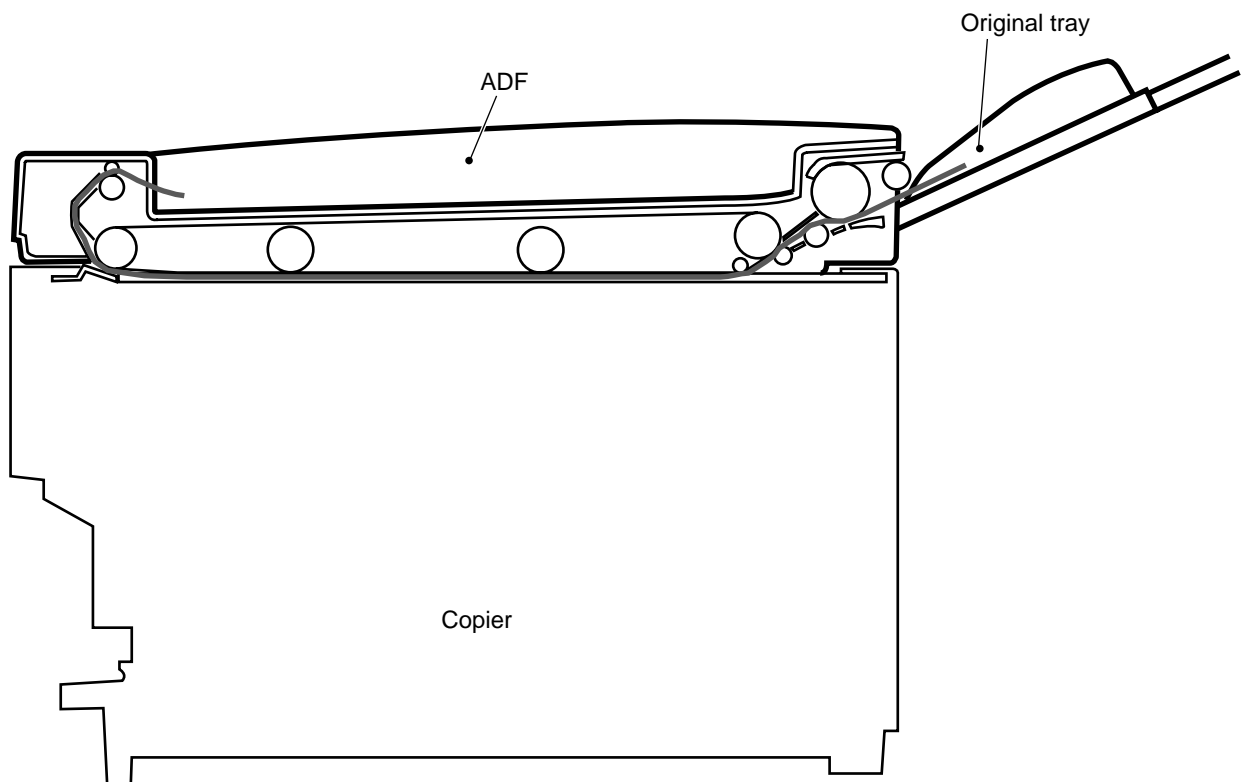

Figure 8-101

## B Basic Construction

### 1. Outline of the Electric Circuitry

The ADF's major electrical mechanisms are controlled by the CPU on the ADF controller PCB.

The CPU on the ADF controller PCB reads the signals from the sensors and the copier and generates signals to drive the motor at such times as programmed in advance.

The copying modes selected on the copier are communicated to the ADF in serial, and the ADF communicates to the copier the state of feeding originals to the copier in serial. (It does not use an IC for communications.)

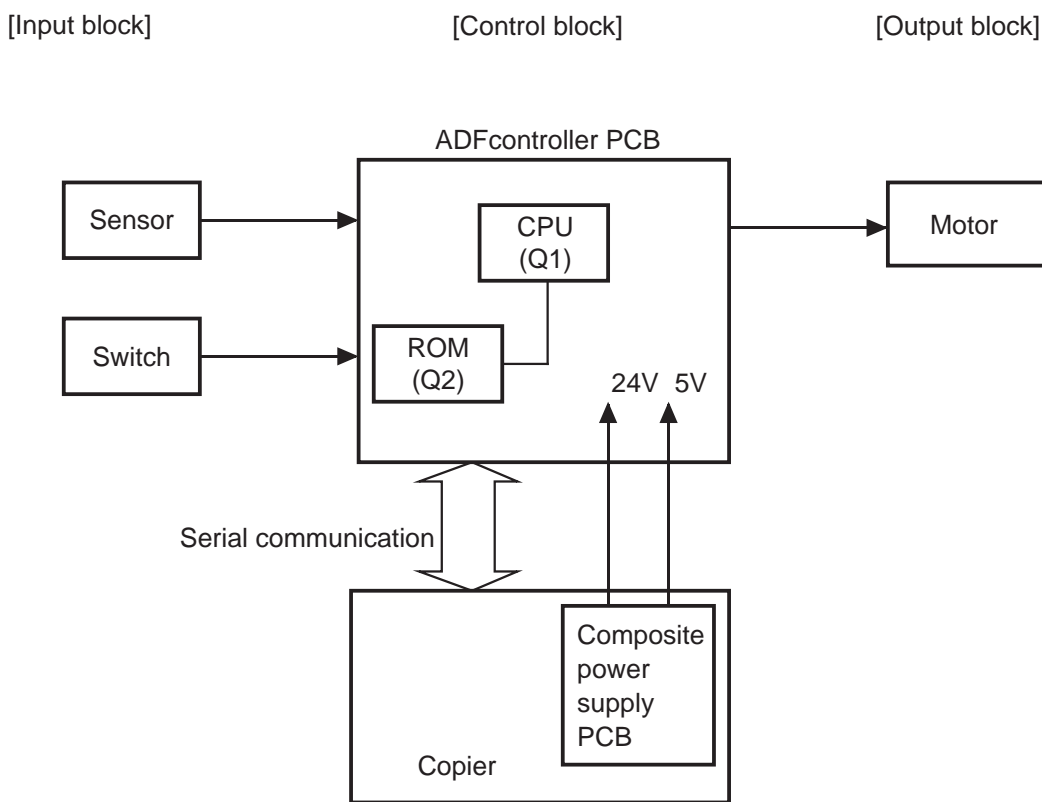

Figure 8-102



2. Inputs to and Outputs from the ADF Controller PCB

a. Inputs to and Outputs from the ADF Controller PCB (1/1)

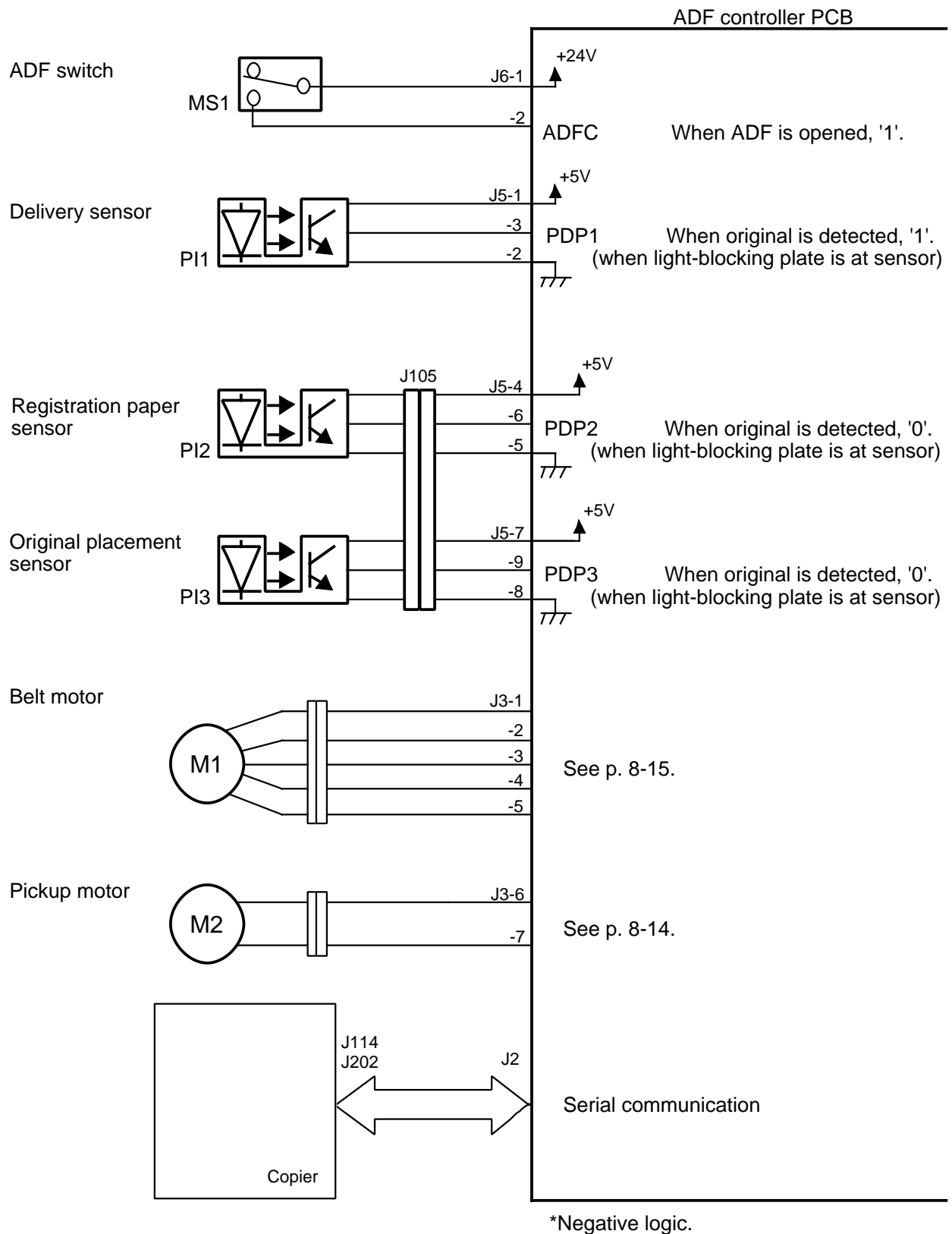

Figure 8-103

### C. Basic Operations

#### 1. Outline

The ADF uses two motors for picking up and delivering originals. The pickup motor (M2) is used to pick up originals, and the belt motor (M1) is used to move, stop, and deliver originals.

Further, the ADF is equipped with three sensors for monitoring the movement of originals. The ADF is designed to accommodate one-sided original copying mode only.

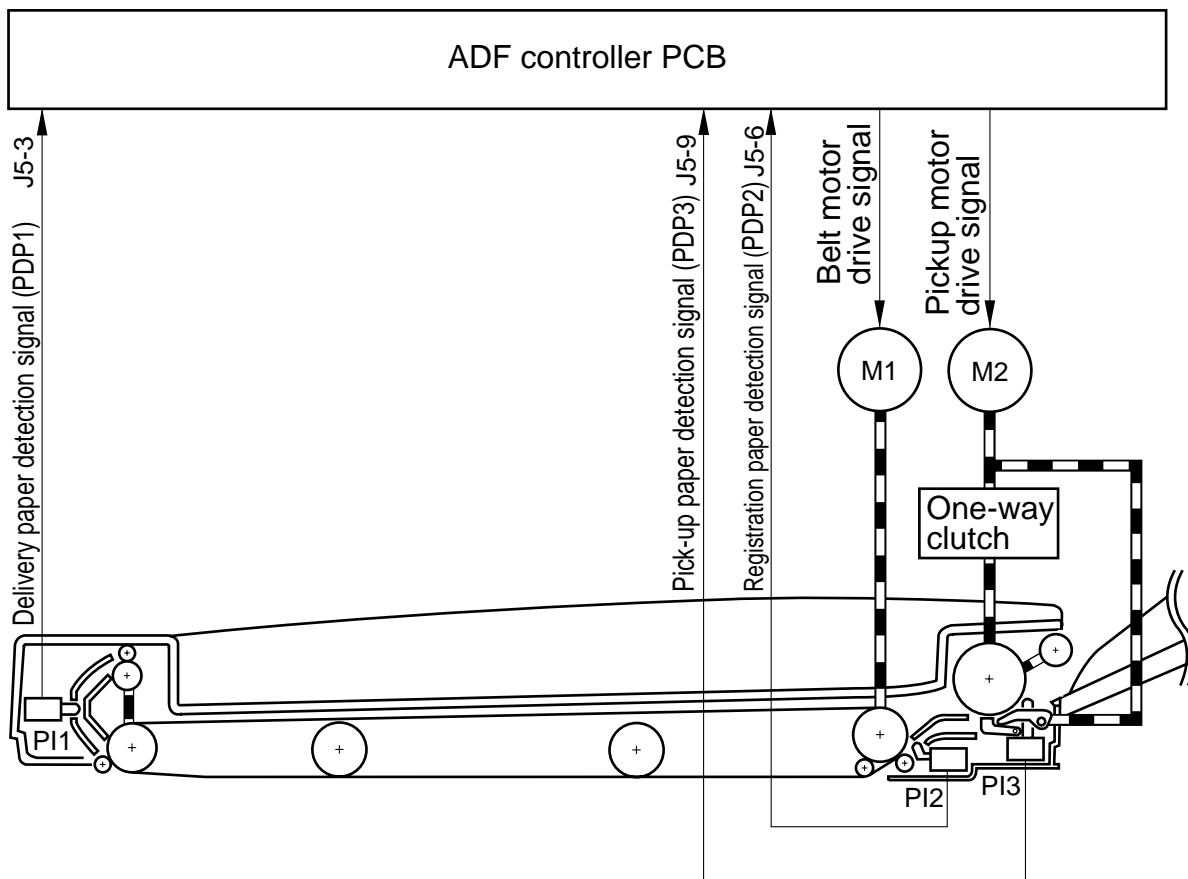
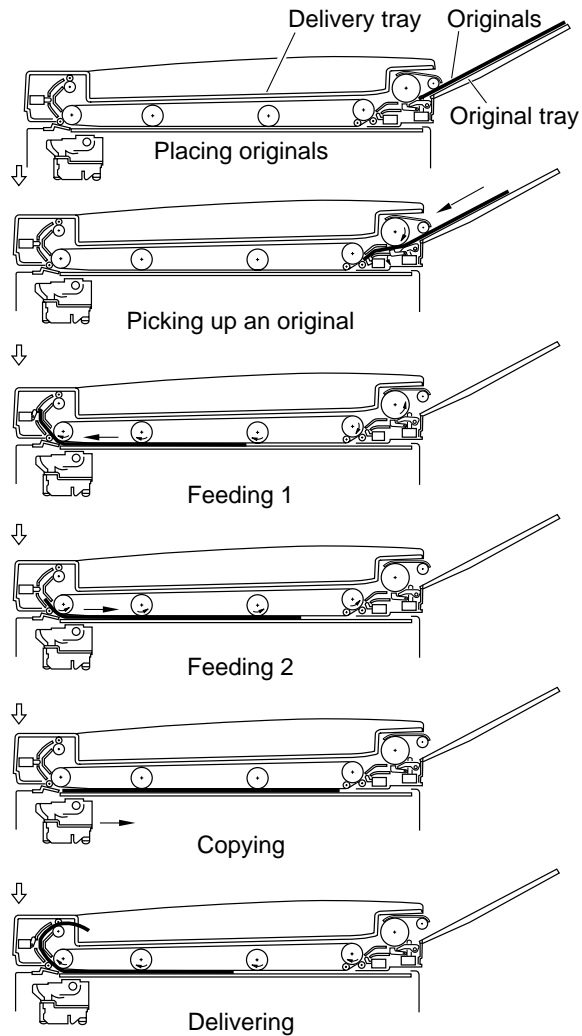

Figure 8-104

## 2. One-Sided Original Mode

The ADF picks up originals stacked on the original tray starting with the topmost original; after it picks up an original, it places it on the copyboard glass for copying, moves it away from the copyboard glass, and delivers it to the copyboard glass.



**Figure 8-105**

## D. Detecting an Original

### 1. Outline

The ADF's original detection mechanism has the following two functions:

1. Detecting the Presence/Absence of an Original  
Checks whether there is an original on the original tray.
2. Identifying the Length of the Original  
Checks the length of the original placed on the original tray.
3. Detecting the Presence/Absence of an Original

The original placement sensor (PI3) is used to check the presence/absence of an original.

When an original is placed on the original tray, the original placement sensor (PI3) sends the original detection signal (PDP3) to the ADF controller PCB in response to the movement of the detecting lever away from the sensor.

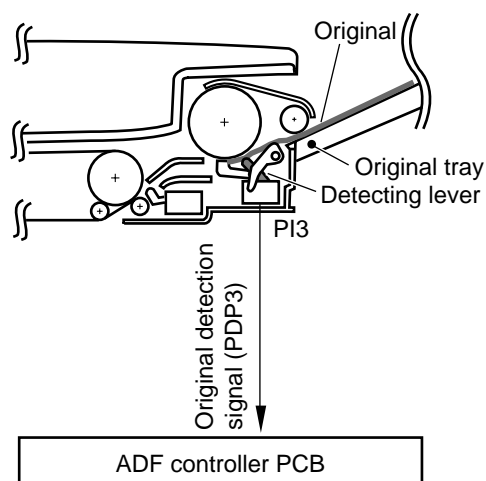

Figure 8-106

## 2. Identifying the Length of the Original

The registration paper sensor (PI2) is used to identify the length of the original, if any.

The ADF controller computes the length of the original based on the time it takes for the original to move past the registration paper sensor (PI2).

Using the result of the computation, the ADF controller determines whether the size of the original is A4/LTR or smaller or LGL, thereby switching to the appropriate ADF operation.

Table 8-101 shows the lengths of originals that determines ADF operation sequence.

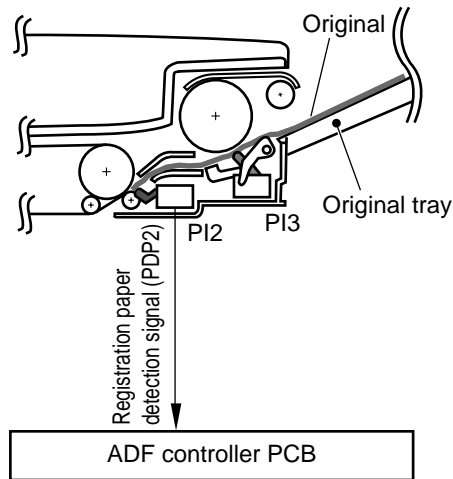

Figure 8-107

Original Lengths and Operation Sequences

Length	Sequence
~313cm	For A4/LTR originals
314cm~	For LGL originals

Table 8-101

## E. Pickup Operation

### 1. Operation

When an original is placed on the original tray and the Copy Start key is pressed, the following sequence of operations takes place:

#### 1 Preparing for PickUp Operation

When an original is placed on the original tray, i.e., the original placement sensor (PI3) turns ON, the pickup roller rotates counterclockwise and the paper guide holds the original in place.

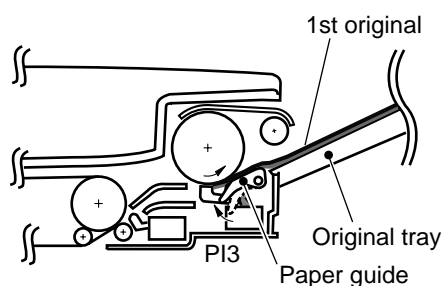

Figure 8-108

#### 2 Pickup Separation

When the Copy Start key is pressed, the pickup roller 1 and 2 rotate clockwise, and pick up the first original (topmost) and forward it as far as the registration roller. (The separation pad ensures that only one original is picked up.)

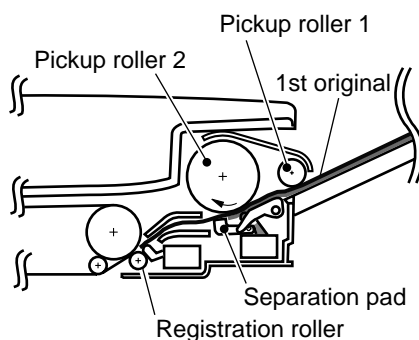
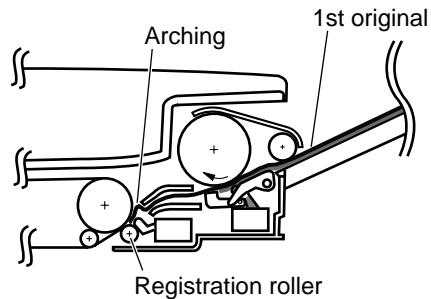

Figure 8-109

### 3 Arching

The first original is butted against the registration roller so that it arches.

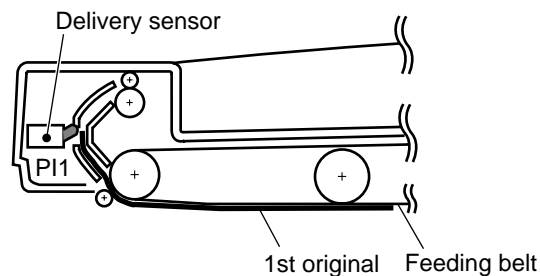

**Figure 8-110**

### 4 Feeding Operation 1

The feeding belt is moved so that the leading edge of the first original comes into contact with the delivery sensor (PI1). (In the case of a LGL original, the original is moved about 15 mm farther after it has come into contact with the delivery sensor.)

At the same time, the pickup motor (M2) is rotated counterclockwise to prepare for picking up the second original.



**Figure 8-111**

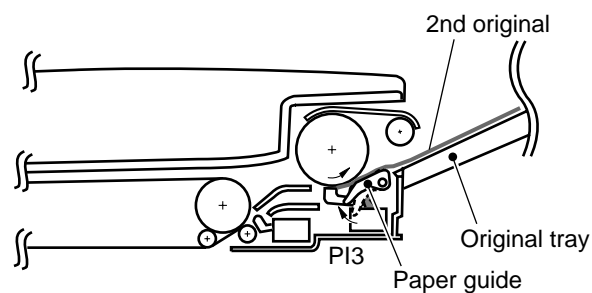

**Figure 8-112**

5 Feeding 2

The feeding belt is moved counterclockwise so that the first original is stopped at a specific location on the copyboard glass.

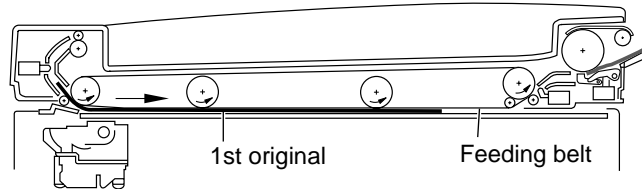

Figure 8-113

6 Moving the Scanner and Picking Up the Second Original

The scanner starts to move forward after the original has been stopped at a specific location on the copyboard glass.

If the original is A4/LTR or smaller, the pickup motor (M2) is also rotated clockwise to pickup the second original and butt it against the registration roller.

If the original is LGL, the second original is picked up after the scanner has been moved forward.

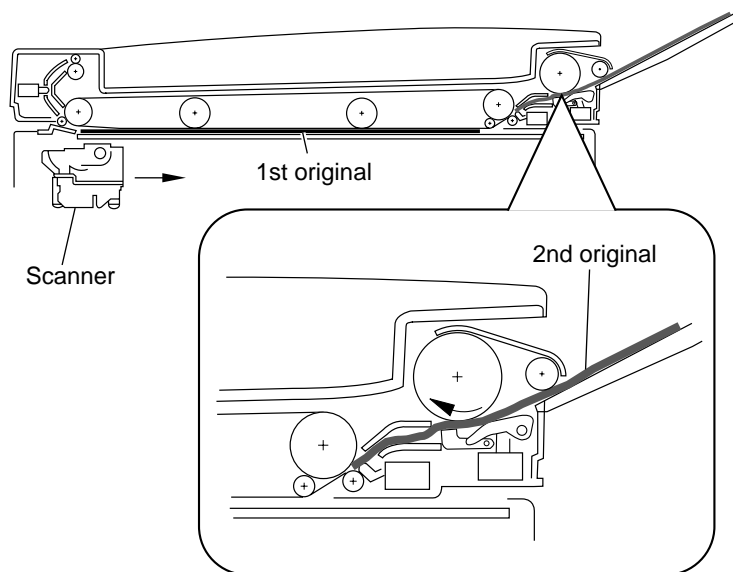

Figure 8-114



### 2. Sequence of Pickup Operations (A4/LTR, 2 originals)

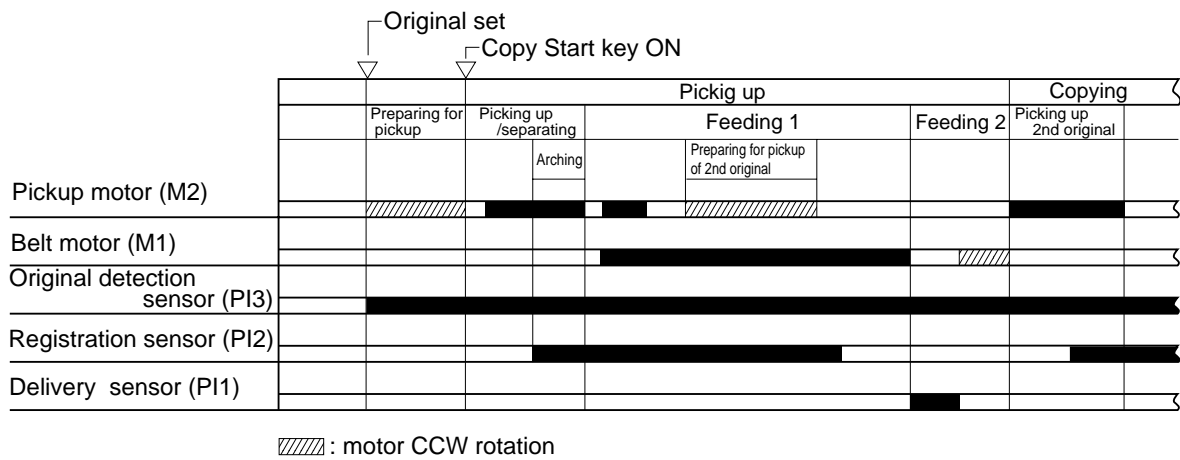

Figure 8-115

### 3. Sequence of Operations (LGL, 2 originals)

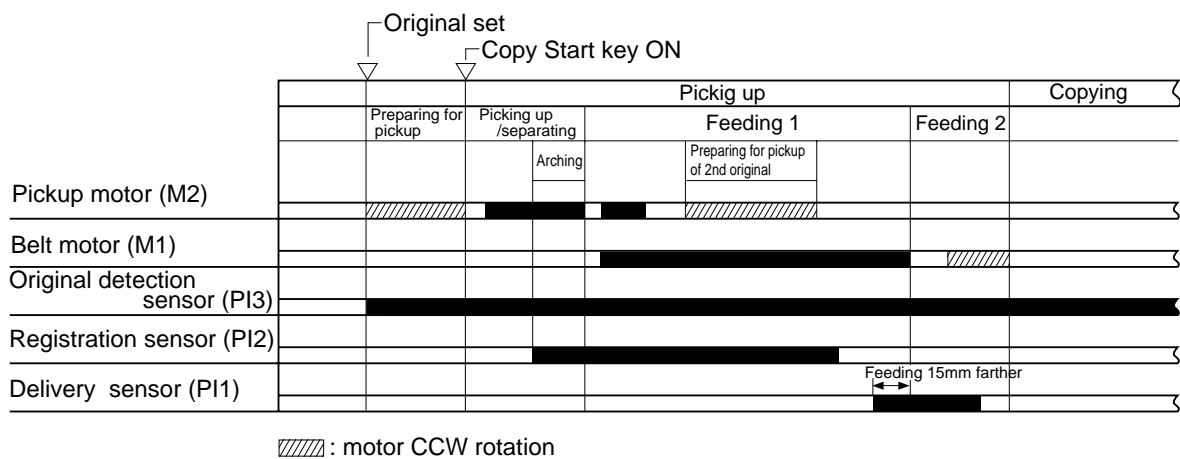

Figure 8-116

## F. Delivery

### 1. Operations

The ADF operates as follows to deliver originals from the copyboard glass:

#### 1 Delivery Feeding

The feeding belt is moved to feed and deliver the first original on the copyboard glass. At the same time, the pickup motor (M2) moves the second original to the copyboard glass.

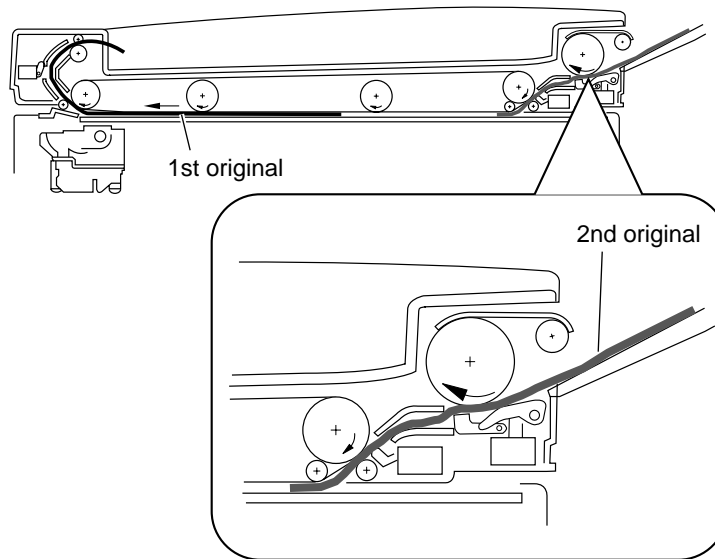

Figure 8-117

#### 2 Delivering to the Delivery Tray

The ADF switches the belt motor to low speed as soon as the trailing edge of the original moves past the delivery sensor (PI1), thereby delivering the original slowly.

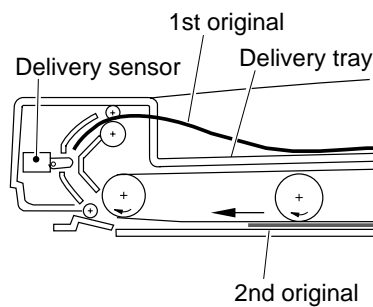

Figure 8-118

### 2. Sequence of Operations (A4/LTR, 2 originals)

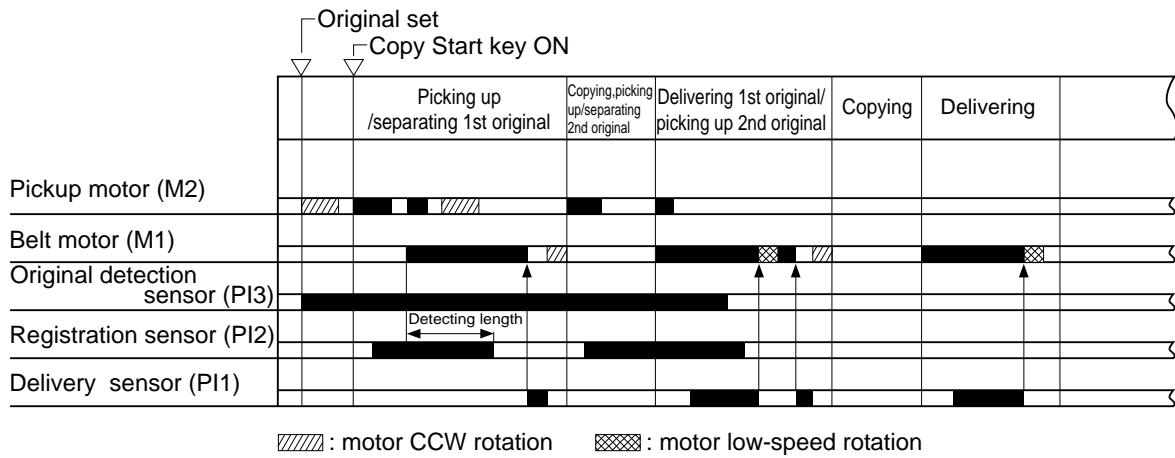

Figure 8-119

### 3. Sequence of Operations (LGL, 2 originals)

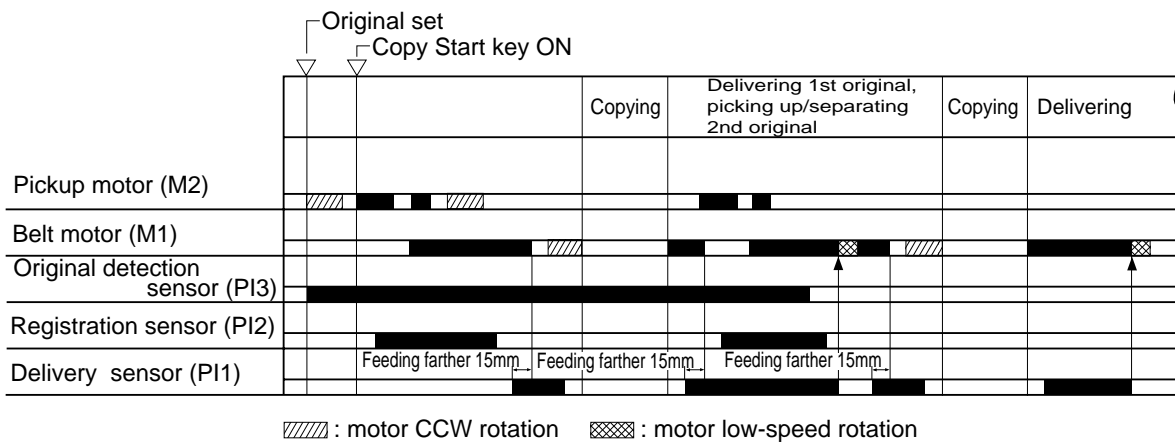

Figure 8-120

## G. Controlling the Pickup Motor

### 1. Outline

Figure 8-121 is a diagram of the control circuit for the pickup motor (M2).

The pickup motor is a DC motor.

The CPU (Q1) on the ADF controller PCB sends the motor drive signals PM0 and PM1 to the motor driver (Q5). The pickup motor rotates clockwise or counterclockwise according to the combinations of the states of these two signals. (Table 8-102 shows how the pickup motor rotates for each combination.)

The motor driver is equipped with a limiter function, preventing overcurrent from flowing into the motor. When an overcurrent occurs, the limiter function cuts off the motor drive current, thereby preventing damage to the motor.

When the limiter function is activated, the pickup motor cannot rotate as controlled, possibly leading to pickup faults. Any pickup fault causes the ADF controller to flash the JAM indicator on the copier and stop the pickup motor at the same time.

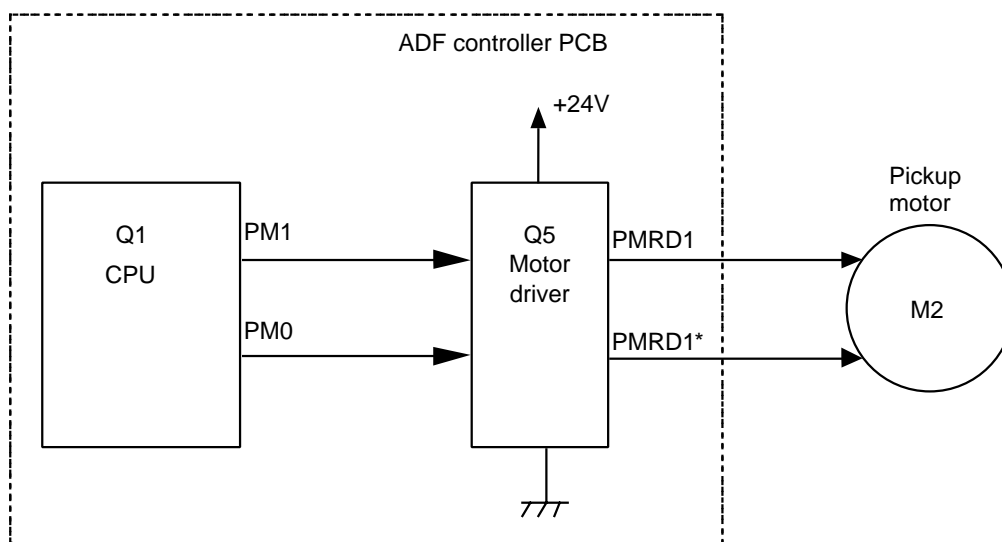

Figure 8-121

Motor drive signal (PM0)	Motor drive signal (PM1)	Pickup roller rotation
'1'	'1'	Braked
'1'	'0'	Picking up
'0'	'1'	Delivering
'0'	'0'	At reset (free)

Table 8-102

## H. Controlling the Belt Motor

### 1. Outline

Figure 8-122 is a diagram showing the control circuit for the belt motor (M2).

The belt motor is a 4-phase control stepping motor.

The CPU (Q1) on the ADF controller PCB sends control pulse signals (A, A\*, B, B\*) to the motor driver (Q4).

In response, the motor driver changes the output timing of the pulse signals (MA, MA\*, MB, MB\*) used for driving the motor to rotate the belt motor clockwise or counterclockwise.

The motor driver is equipped with a limiter function used to keep the motor supplied with a specific current so that current greater than specified will not flow.

If loads large enough to activate the limiter function occur in succession, the belt motor cannot rotate as specified, possibly leading to feeding faults. Any feeding fault will cause the ADF controller to flash the Jam indicator on the controller and stop the belt motor at the same time.

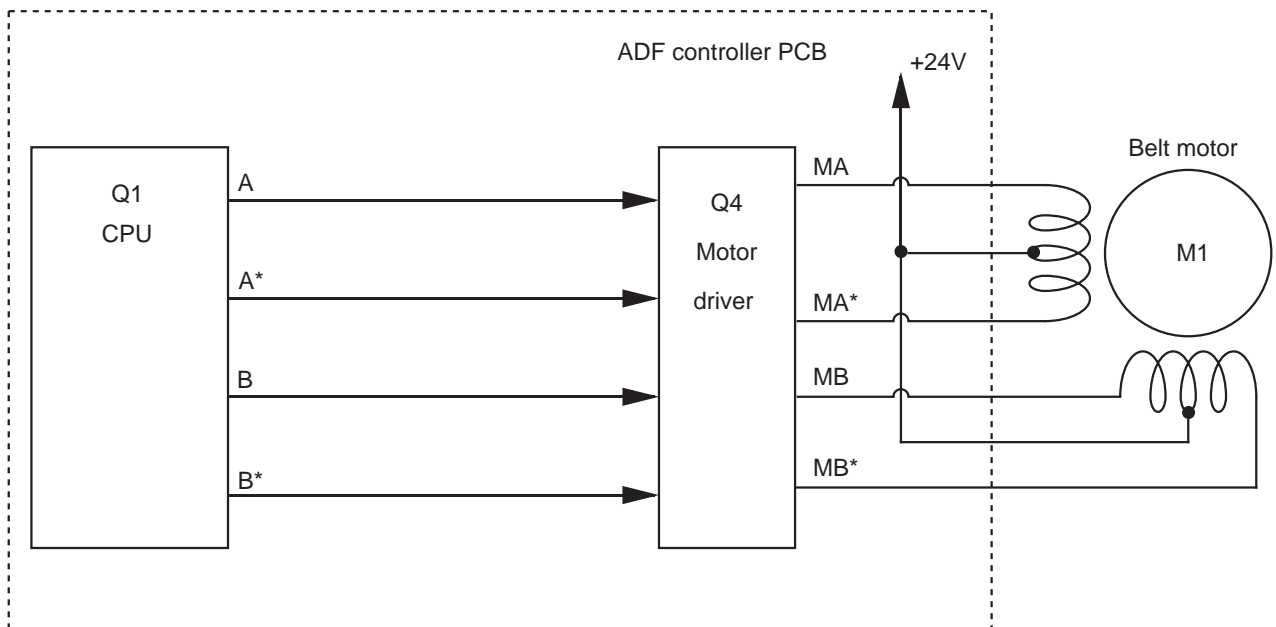

Figure 8-122

## I. Detecting Original Jams

The ADF is equipped with three jam sensors (PI1 through PI3) as indicated in Figure 8-123 to monitor the movement of originals.

The movement of originals are checked at such times as programmed in the CPU on the ADF controller PCB; a jam is identified in relation to the presence of an original at each sensor.

Table 8-103 describes the type of jam, condition of detection, and sensors involved.

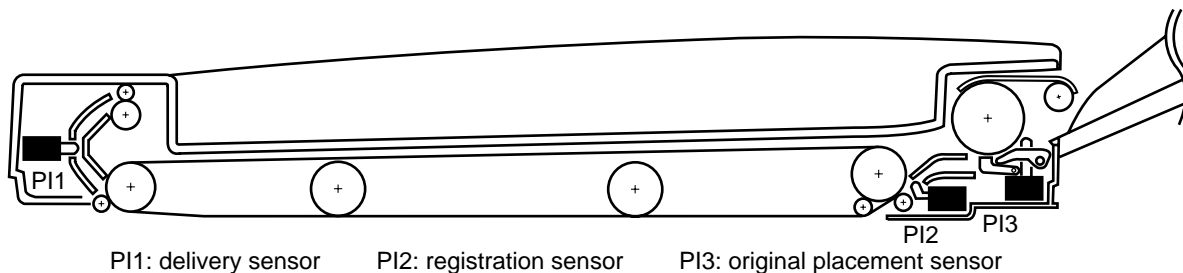

**Figure 8-123**

Type of Original Jam and Condition of Detection

Operation	Type of jam	Sensor	Conditions
Pickup	Residual original	PI1,PI2	When the 1st original is separated, the delivery sensor (PI1) turns on while the belt motor rotates for 300 ms or less or before the registration sensor (PI2) turns on. When the 1st original is picked up, the registration sensor (PI2) and the delivery sensor (PI1) turn on.
	Original present at start	PI1,PI2	When separation starts, the registration sensor (PI2) or the delivery sensor (PI1) are on.
	Separation delay	PI2	When separation starts, the registration sensor (PI2) does not turn on after 2 sec.
	Pick-up delay	PI2	When pickup starts, the registration sensor (PI2) does not turn off after feeding the original for about 500 mm.
Delivery	ADF open	MS1	The ADF is opened while in operation.
	Delivery delay jam	PI1,PI2	When delivery starts, the delivery sensor (PI1) does not detect an original that has been fed about 100 mm. After the registration sensor (PI2) has turned off, the delivery sensor (PI1) does not detect an original that has been fed for about 500 mm.
	Delivery stationary jam	PI1	During pickup, the delivery sensor (PI1) remains on even when the original is fed for 'length + about 60 mm'.

**Table 8-103**

## J. Power Supply

### 1. Outline

Figure 8-124 shows the routes of power supply.

The ADF is supplied by the copier with 5 V and 24 V. The 24V supply is cut off when the ADF is opened, i.e., when the ADF switch (MS1) turns off. The 5V supply will continue to keep each sensor powered even when the ADF is opened.

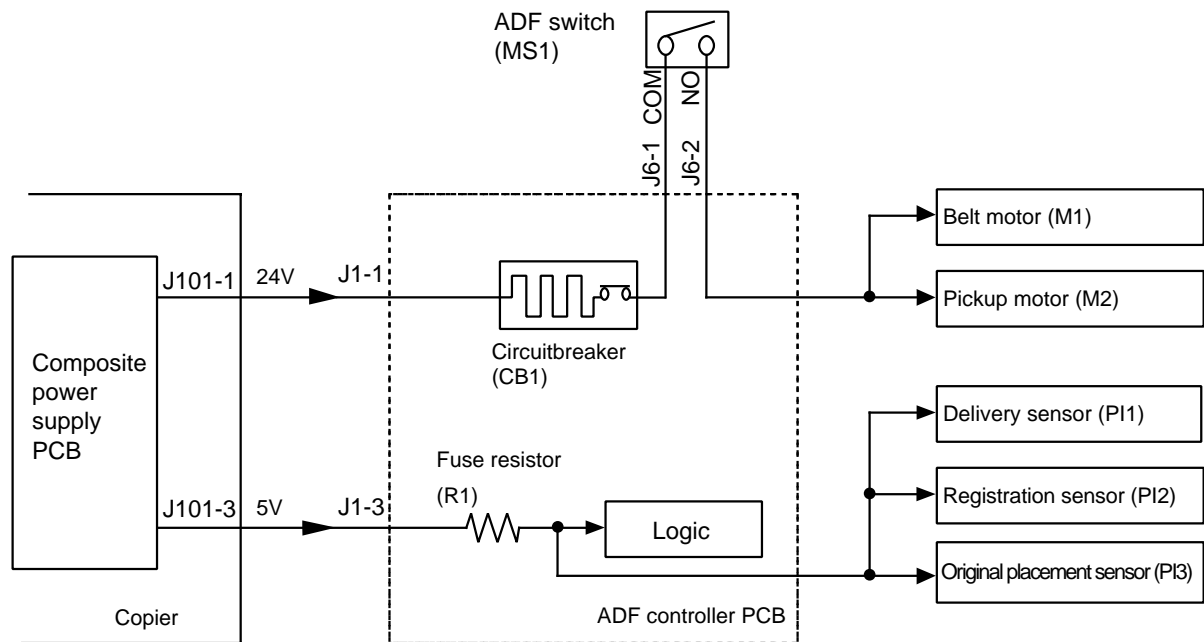

Figure 8-124

## II. DISASSEMBLY/ASSEMBLY

As needed, disassemble/assemble the machine with the following in mind:

1. **▲** Before starting the work, turn off the power switch and disconnect the power plug for safety.
2. Unless otherwise instructed, assemble the parts by reversing the steps used to disassemble it.
3. Identify the screws by type (length, diameter) and location.
4. Use the washers where necessary. (The screws used to mount the grounding wire and Varistors come with a washer to ensure electrical continuity.)
5. As necessary, cut the harness band.
6. As a rule, do not operate the machine with any of its part removed.
7. A few of the screws used are special screws (with wider thread intervals). Do not use any screws indiscriminately.



## A. Removing the ADF

- 1) Open the machine's top unit.
- 2) Free the two claws [1], and slide the left cover [2] to detach.

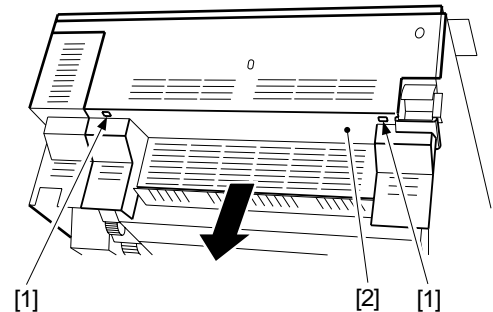

**Figure 8-201**

- 3) Remove the screw [3], and free the four claws [4]; then, detach the rear cover [5].

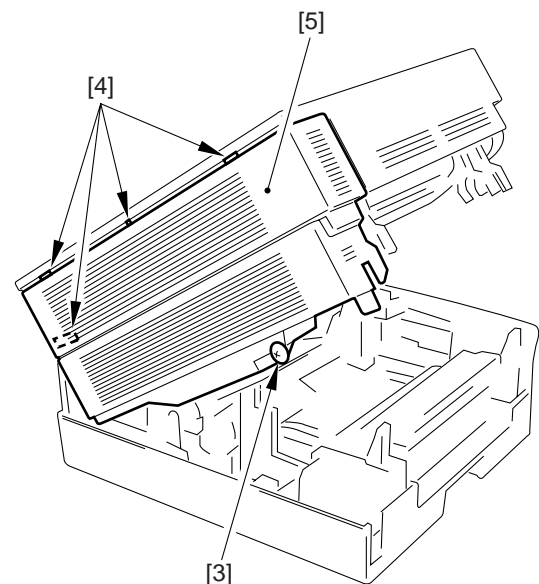

**Figure 8-202**

- 4) Close the machine's top unit.
- 5) Remove the two screws [6], and remove the fixing plate [7].

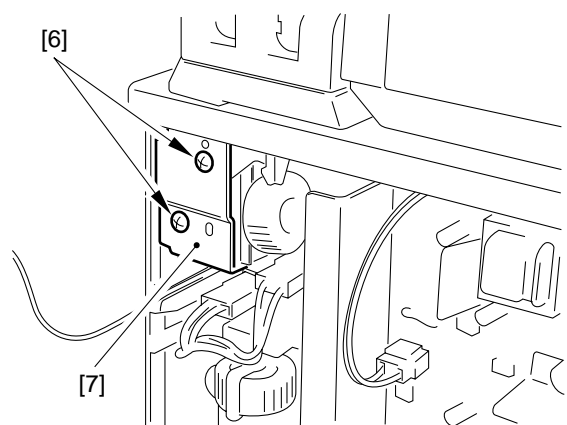

**Figure 8-203**

- 6) Disconnect the two connectors [8], and remove the screw [9]; then, remove the cable bush [10].

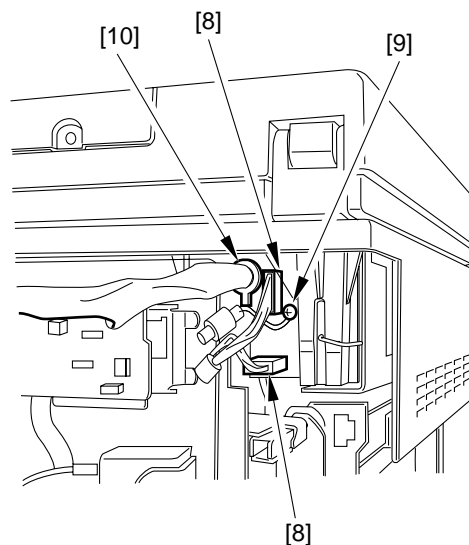

Figure 8-204

- 7) Remove the two lockpin [11], and remove the ADF from the copier.

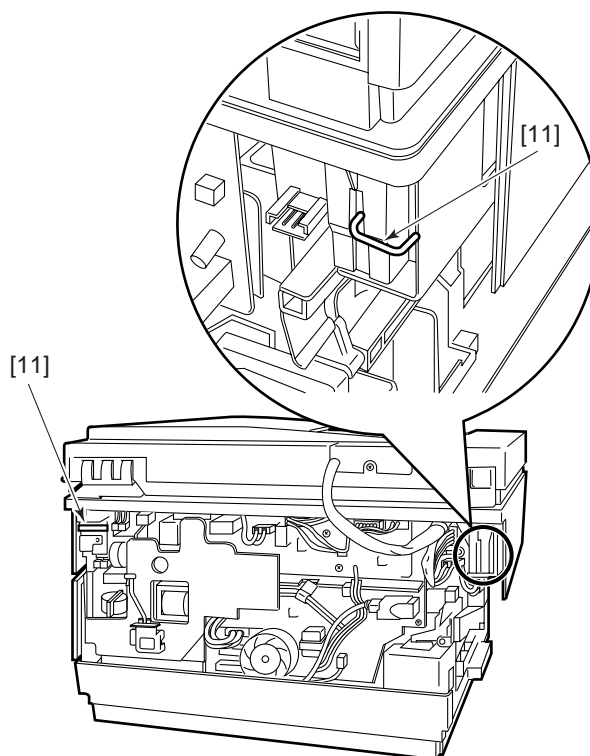
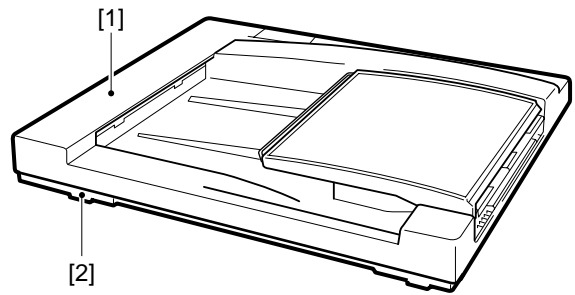

Figure 8-205

## B. External Covers



[1] Upper cover      [2] Lower cover

**Figure 8-206**

Remove the covers as follows when cleaning, checking, or repairing the inside of the machine:

- 1) Remove the ADF from the copier.  
(See “A. Removing the ADF.”)
- 2) Remove the feeding roller [1] from the bushing [2].

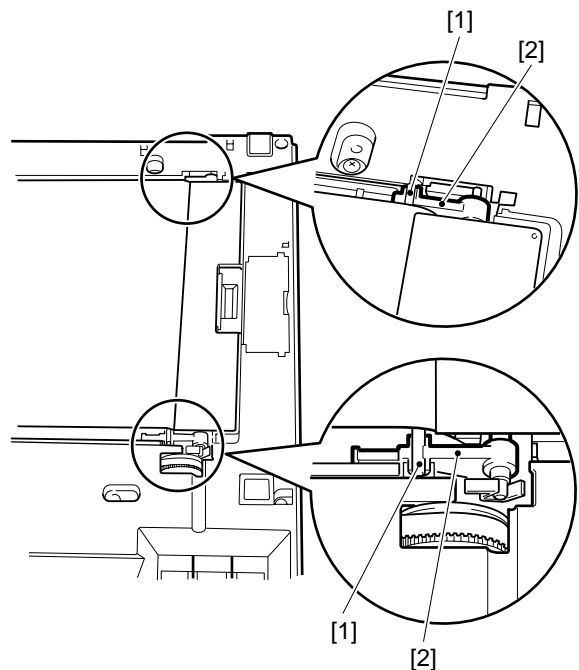

**Figure 8-207**

- 3) Remove the six screws [3], and separate the lower cover [4] from the upper cover [5].

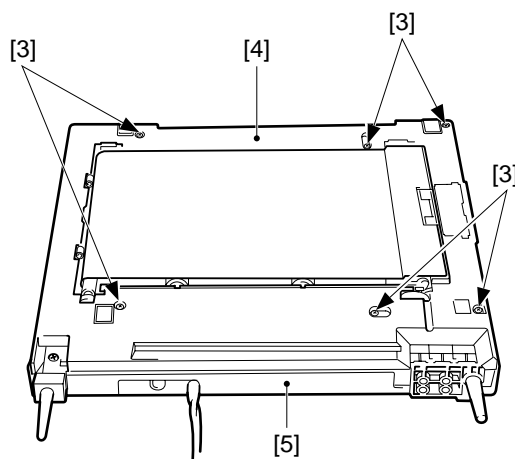

Figure 8-208

- 4) Disconnect the connector [6], and remove the lower cover [4].

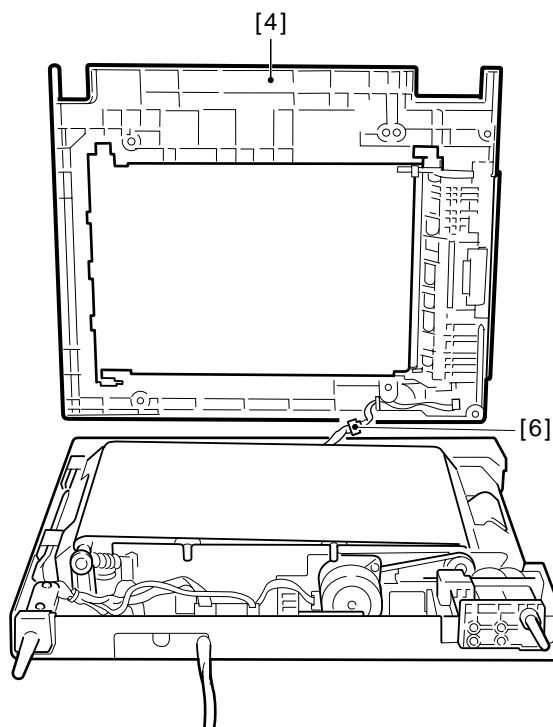

Figure 8-209

## C. Drive System

### 1. Drive Unit

- 1) Remove the lower cover.  
(See "B. External Covers.")
- 2) Remove the screw [1] and the bushing [2];  
then, remove the pickup roller cover [3].

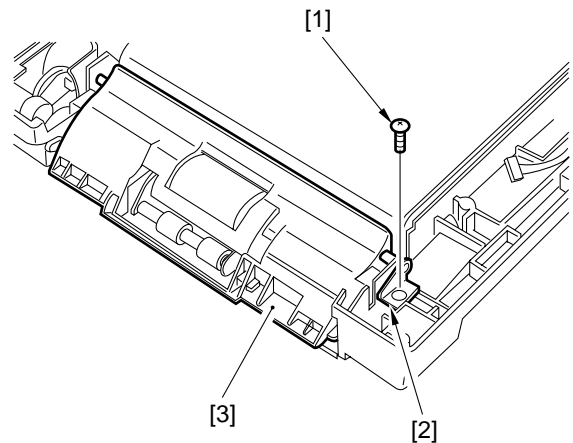

Figure 8-210

- 3) Remove the E-ring [4], and remove the  
bearing [5].

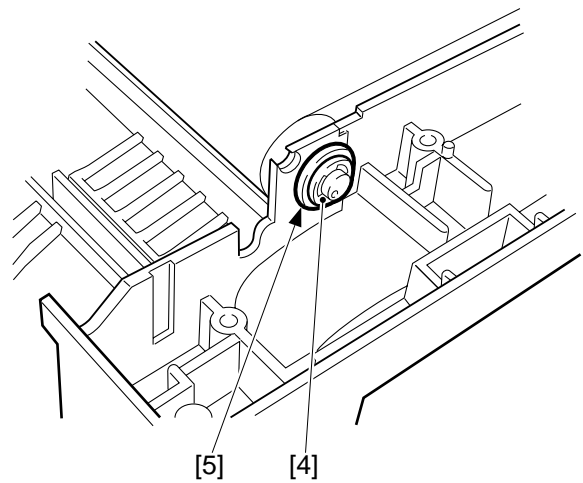

Figure 8-211

- 4) Remove the timing belt [6], and remove the feeding belt roller [7] by shifting it in the direction of the arrow.

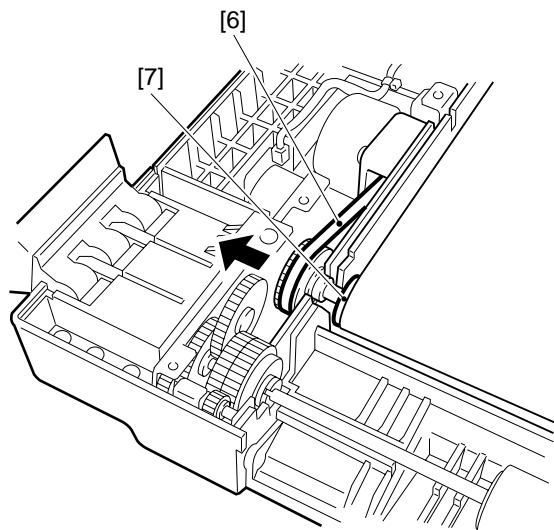

Figure 8-212

- 5) Remove the five screws [9], and remove the right hinge unit [8].

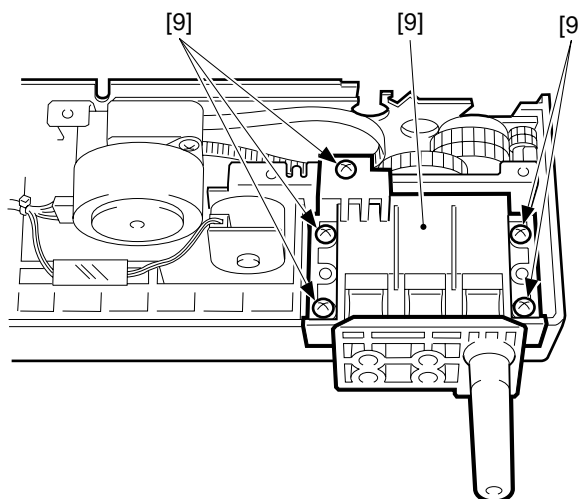

Figure 8-213

- 6) Remove the stop ring [10] (resin) and the bushing [11].

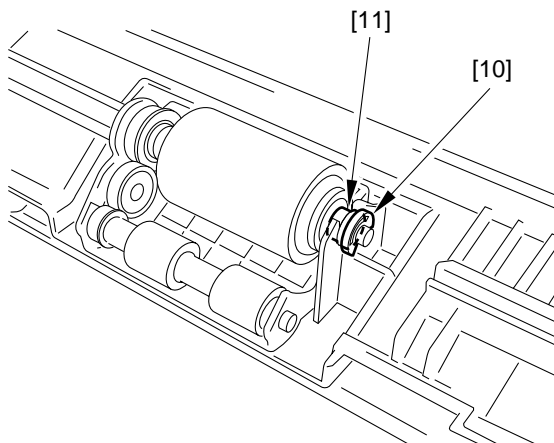

Figure 8-214

- 7) Disconnect the two connectors [12], and remove the five screws [13]; then, remove the drive unit [14].

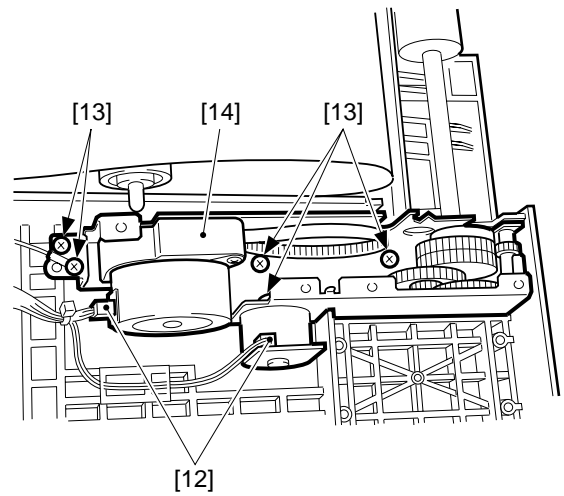

Figure 8-215

## D. Feeding System

### 1. Pickup Roller

- 1) Remove the drive unit [1].  
(See "C.1. Drive Unit.")

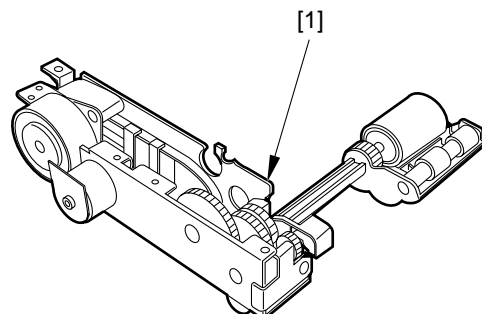

Figure 8-216

- 2) Remove the E-ring [2], and remove the shaft [3]; then, detach the pickup roller 1 [4].

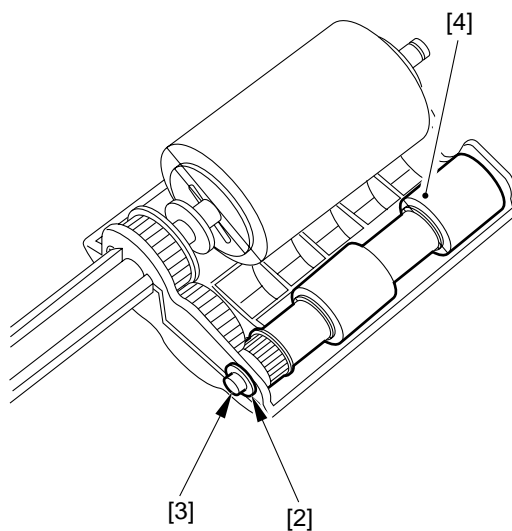

Figure 8-217

- 3) Remove the stop ring [5].

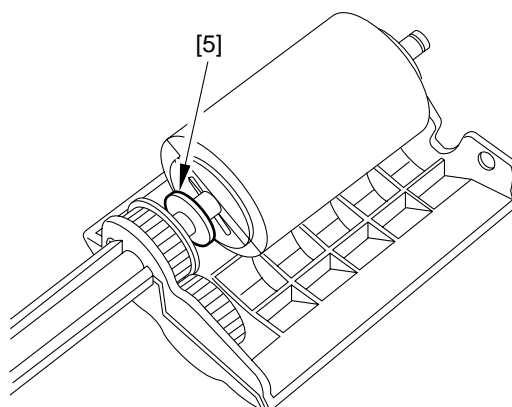

Figure 8-218



- 4) Remove the two straight pins [6], and remove the pickup roller 2 [8] while moving the cover [7] in the direction of the arrow.

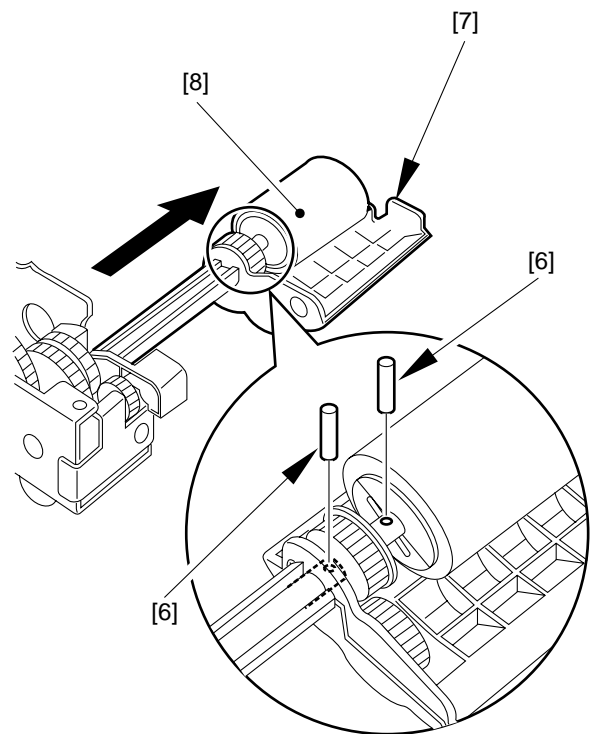

Figure 8-219

## 2. Registration Roller

- 1) Remove the lower cover.  
(See “B. External Covers.”)
- 2) Remove the link arm [1] from the registration roller shaft [2] by turning the link arm.

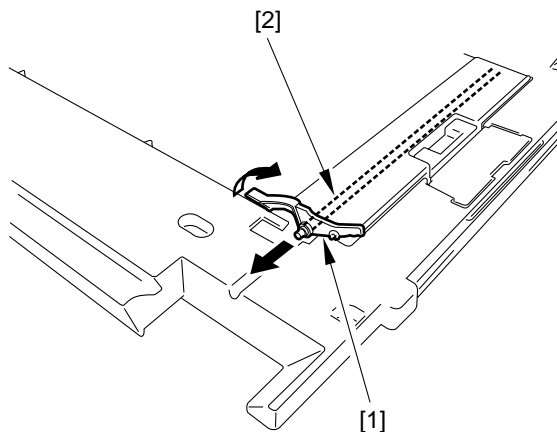

Figure 8-220

- 3) While pushing the bushing [3] in the direction of the arrow, pull out the registration roller shaft [2] slowly.

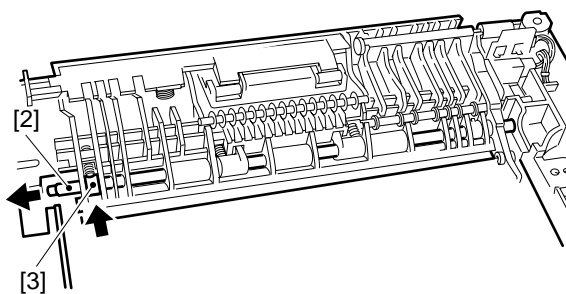

Figure 8-221

### 3. Feeding Belt

- 1) Remove the lower cover.  
(See "B. External Covers.")
- 2) Remove the two tension springs [1].

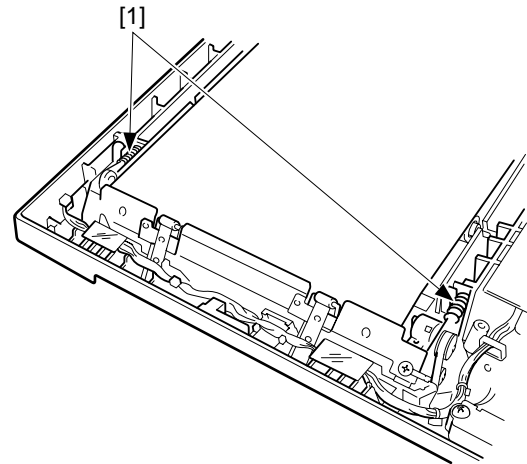

Figure 8-222

- 3) Remove the E-ring [2], and remove the bearing [3].

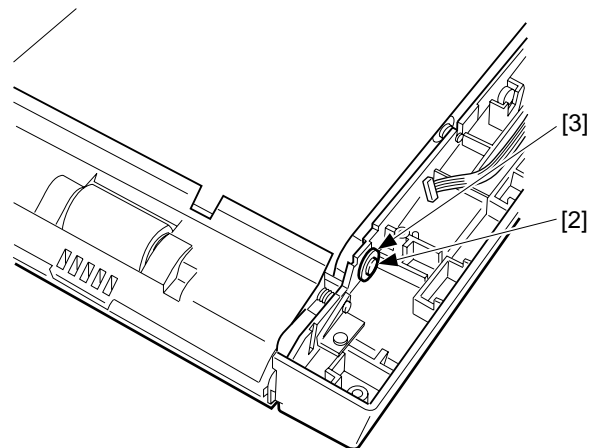

Figure 8-223

- 4) Remove the timing belt [4], and remove the feeding belt drive roller [5] by moving it in the direction of the arrow.

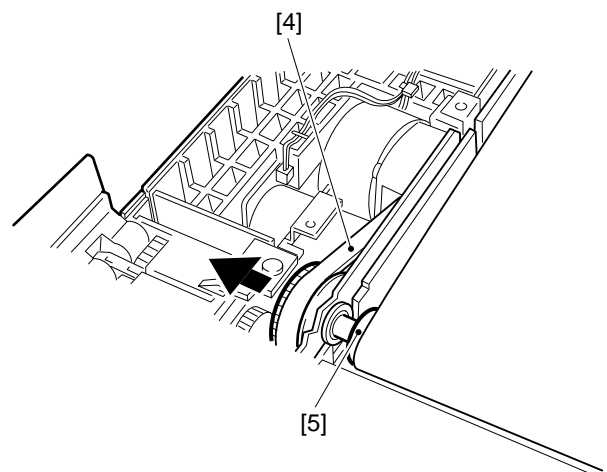

Figure 8-224

- 5) Remove the two equalizer spring [6] and the two feeding belt rolls [7].

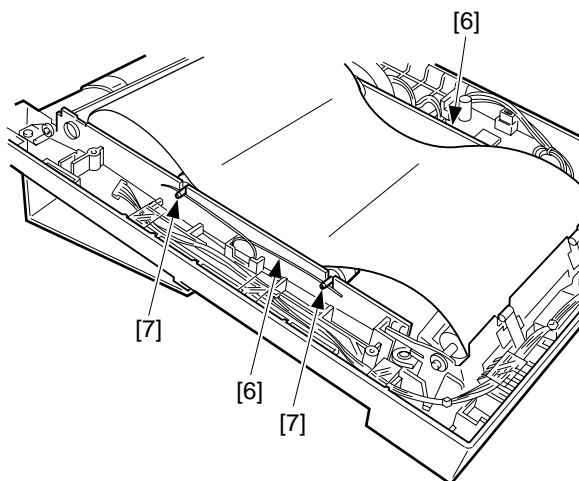

Figure 8-225

- 6) Remove the two screws [9], and remove the delivery sensor unit [8].

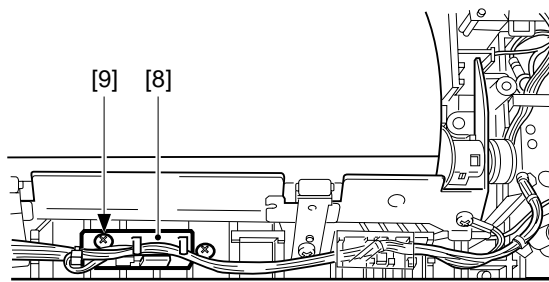

Figure 8-226

- 7) Remove the stop ring [10] (made of resin); then, remove the bushing [11].

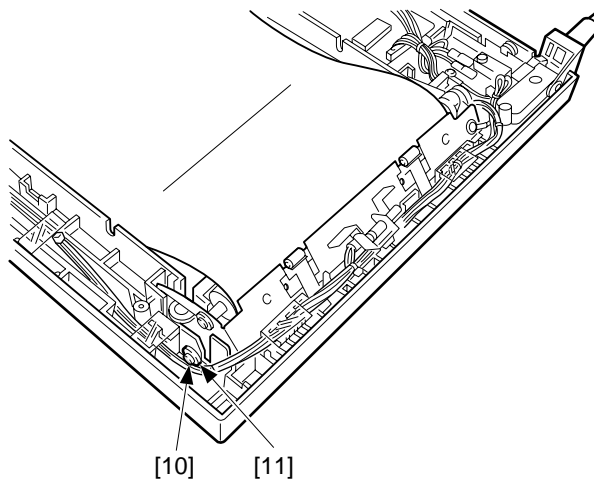

Figure 8-227

- 8) Remove the screw [12], and remove the grounding wire [13]; then, remove the delivery roller unit [14] by moving it in the direction of the arrow.

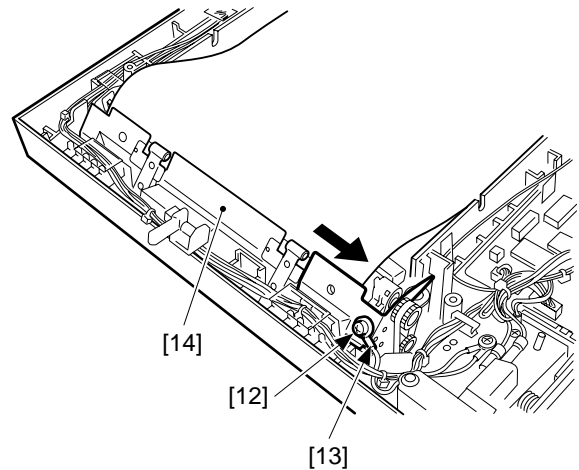

Figure 8-228

- 9) Remove the screw [15], and remove the static eliminating brush [16].

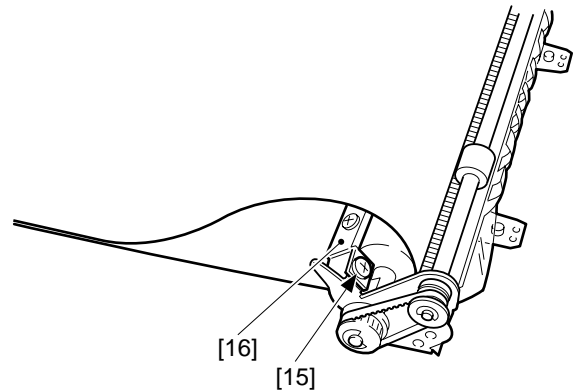

Figure 8-229

- 10) Remove the two E-rings [17]; then, remove the timing belt [18], gear [19], and two bushings [20].

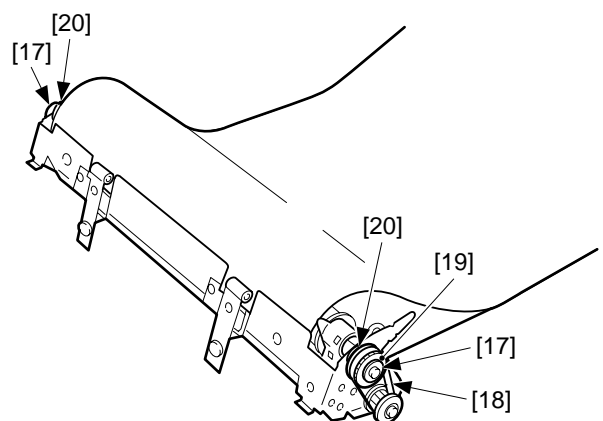

Figure 8-230

- 11) Pull out the actuator [21] in the direction of the arrow; then, remove the feeding belt link roller [22], and remove the feeding belt [23].

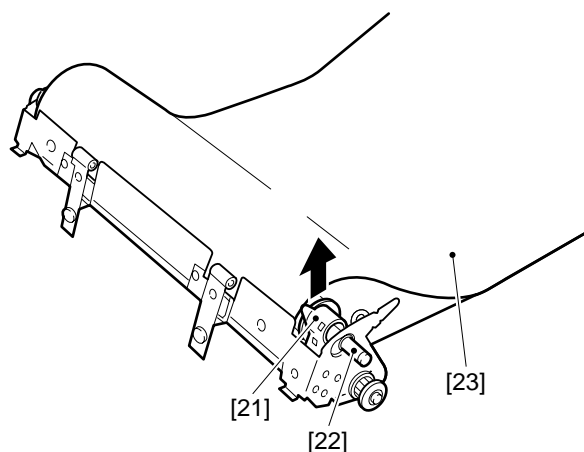

Figure 8-231

## E. Electrical System

### 1. ADF Controller PCB

- 1) Remove the lower cover.  
(See “B. External Covers.”)
- 2) Disconnect the five connectors [1], and remove the two screws [2]; then, remove the ADF controller PCB [3].

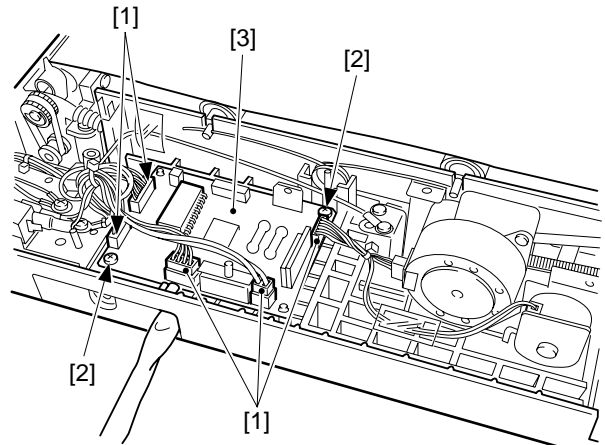

Figure 8-232

### 2. Original Placement Sensor and Registration Paper Sensor

Pay attention to the colors of the cables and connectors when connecting the connectors of the original placement sensor and the registration paper sensor.

Sensor	Cable color
Original placement sensor	Purple
Registration paper sensor	Yellow

Table 8-201

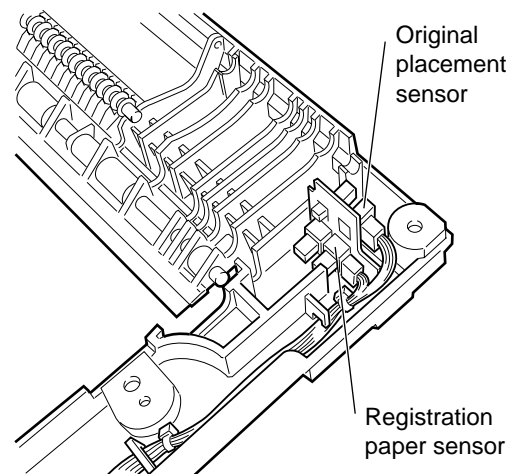

Figure 8-233





---

# CHAPTER 9

---

## INSTALLATION

---

I. SELECTING THE SITE .....	9-1	B. Placing Copy Paper.....	9-18
II. UNPACKING AND INSTALLATION .....	9-2	III. MOVING THE MACHINE .....	9-21
A. Unpacking and Installation ....	9-2		



## I. SELECTING THE SITE

Keep the following in mind when selecting a site for installation; if possible, visit the user's before delivery of the machine:

- The site offers a power outlet whose rating is as specified ( $\pm 10\%$ ) and which may be used exclusively for the machine.
- The site is between  $7.5^{\circ}\text{C}/45.5^{\circ}\text{F}$  and  $32.5^{\circ}\text{C}/90.5^{\circ}\text{F}$  in temperature and between 5% and 85% in humidity. Avoid an area near water faucets, water boilers, humidifiers, and refrigerators.
- Avoid areas near sources of fire. The site must not be subject to ammonium gas or direct rays of the sun. (As necessary, provide curtains.)
- The site must be well ventilated.

The level of ozone generated by the machine should not affect the health of people around it. Some, however, may find the odor to be rather unpleasant, and ventilation is a very important factor.

- The floor of the site must ensure that the machine's feet will remain in contact, and will hold the machine level.
- The machine must be at least 10 cm/3.9 in. away from any wall, and there must be adequate space for work involving the machine.

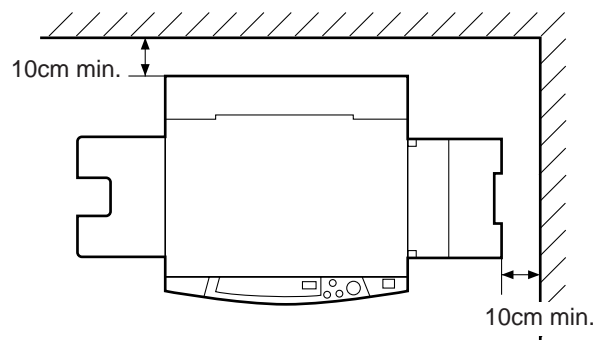

**Figure 9-101**

## II. UNPACKING AND INSTALLATION

When a piece of metal is brought in from a cold to warm place, droplets of water tend to form on its surface. This phenomenon is known as "condensation" and, in machines, can cause blank copies.

If the machine has been brought in from a cold place, leave it alone at least for one hour before starting to install it.

### A. Unpacking and Installation

#### 1. Setting up the Machine

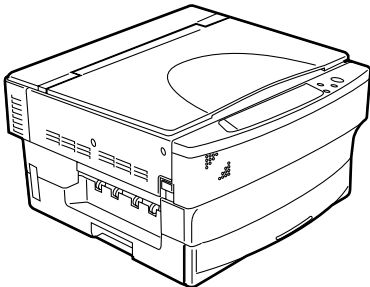
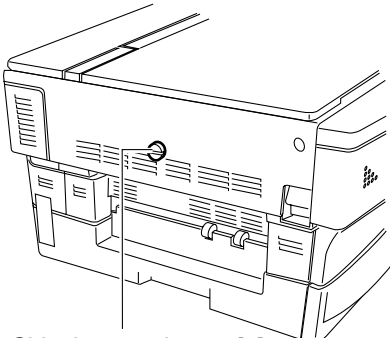
Step	Work	Checks and remarks
1	Take out the machine and the attachments from the shipping box, and check to make sure that none is missing:	<ul style="list-style-type: none"> <li>• Cassette</li> <li>• Copy tray</li> <li>• Power cord</li> <li>• ADF auxiliary tray (ADF type only)</li> <li>• User's Manual</li> <li>• Manual feed tray (for some areas only)</li> <li>• Language label for cassette (included with universal cassette)</li> <li>• Language label for ADF (ADF type only)</li> <li>• Label</li> </ul>
2	Remove the packaging bag and all fixing tape.	
3	Remove the shipping attachment [1] (gold-colored screw) from the left of the machine	 <p data-bbox="927 1832 1182 1861">Shipping attachment [1]</p> <p data-bbox="826 1872 1369 1935">You will be storing the shipping attachment [1] inside the machine in step 10.</p>

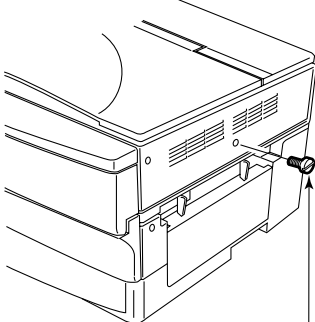
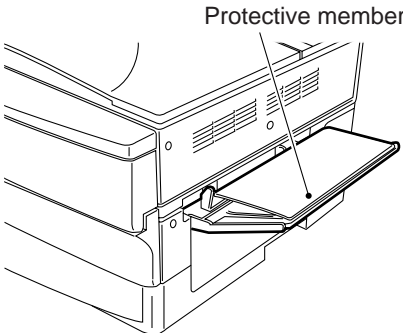
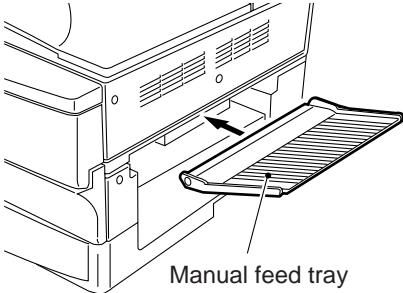
Step	Work	Checks and remarks
4	Remove the shipping attachment [2] (black screw) from the right side of the machine.	 <p>Shipping attachment [2]</p> <p>You will be storing the shipping attachment [2] inside the machine in step 10.</p>
5	<p>Take out the protective member from the manual feed tray.</p> <p><b>Caution:</b> This step applies only if the manual feed tray is attached.</p>	 <p>Protective member</p>
	<p>Attach the manual feed tray that comes with the machine.</p> <p><b>Caution:</b> This applies only if the manual feed tray comes packaged with the machine.</p>	 <p>Manual feed tray</p>

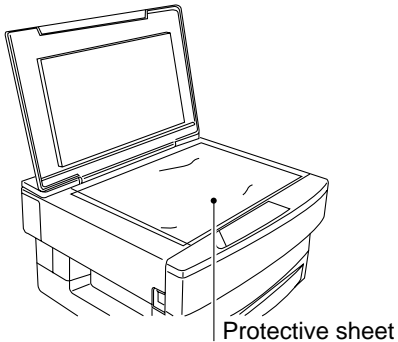
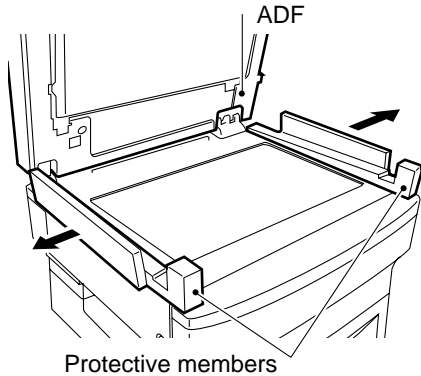
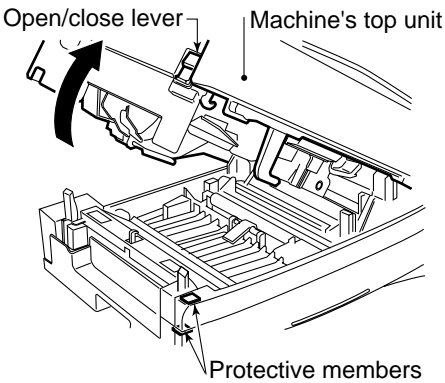
Step	Work	Checks and remarks
6	<p>Open the copyboard cover, and remove the protective sheet; then, close the cover. (Copyboard type only)</p> <p><b>Caution:</b> If the protective sheet is not found on the machine, go to the next step.</p>	
	<p>Open the ADF, and remove the protective members; then, close the ADF. (ADF type only)</p> <p><b>Caution:</b> You will need this protective member when relocating the machine. Be sure to store it away appropriately.</p>	
7	<p>Pull the open/close lever found on the left of the machine to open the machine's top unit; then, remove the two protective members.</p> <p><b>Caution:</b> If the protective member is not found on the machine, go to the next step.</p>	

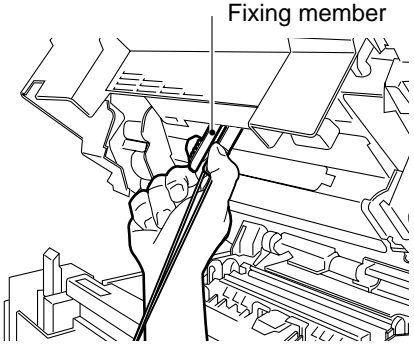
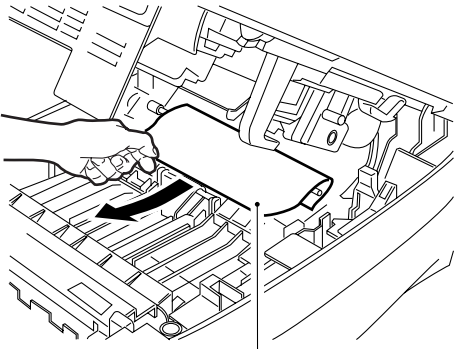
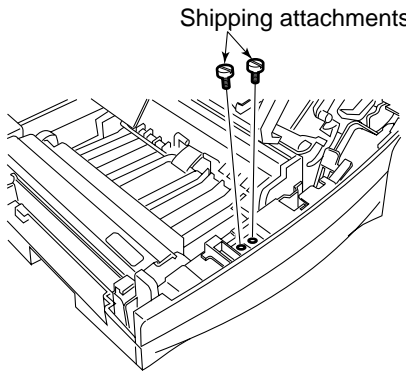
Step	Work	Checks and remarks
8	Pick the fixing member from the bottom of the top unit, and detach it.	 <p>Fixing member</p>
9	Remove the sheet from the bottom of the machine by pulling it in the direction of the arrow.  <b>Caution:</b> If the sheet is not found on the machine, go to the next step.	 <p>Sheet</p>
10	Store the shipping attachments [1] and [2] removed in steps 3 and 4 in the machine's bottom unit.	 <p>Shipping attachments</p>

## 2. Installing the Drum unit

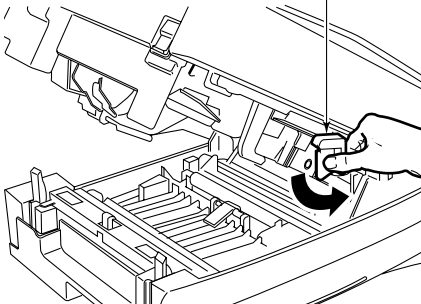
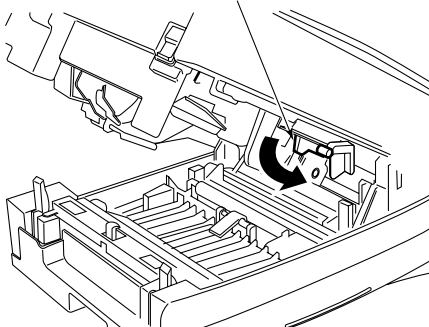
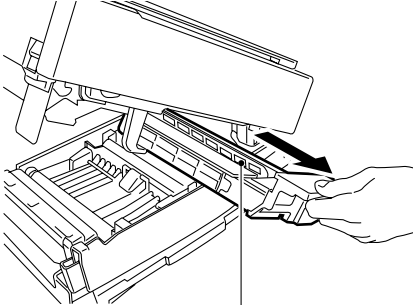
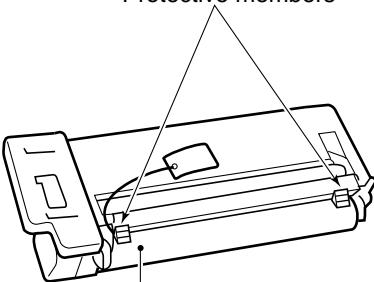
Step	Work	Checks and remarks
1	Turn the developing assembly locking lever counterclockwise.	<p>Developing assembly locking lever</p> 
2	Turn the drum unit releasing lever counterclockwise.	<p>Drum unit releasing lever</p> 
3	Remove the drum unit.	 <p>Drum unit</p>
4	<p>Place the drum unit on a flat surface, and remove the two protective members.</p> <p><b>Note:</b> _____ Do not touch the surface of the drum when handling the drum unit. _____</p>	<p>Protective members</p>  <p>Surface of the drum</p>



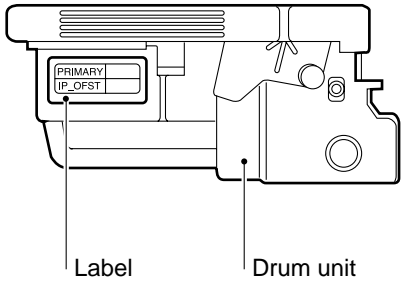
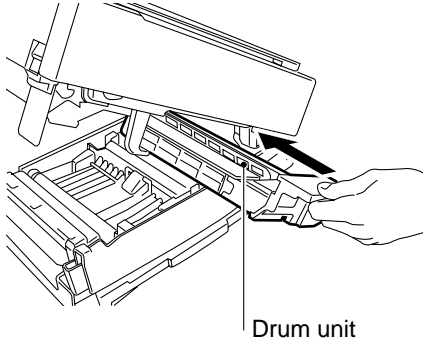
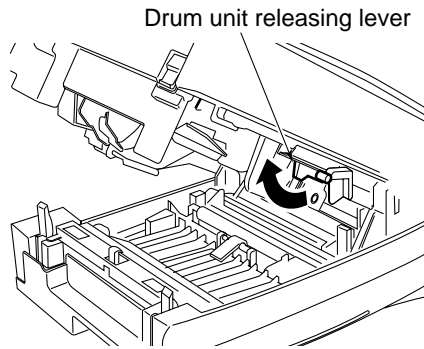
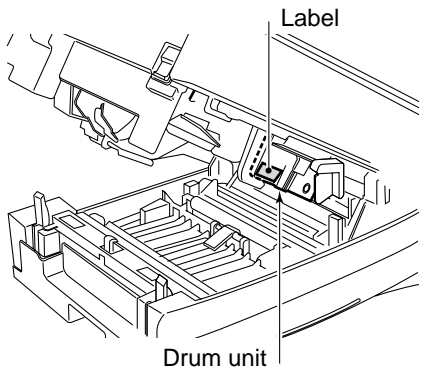

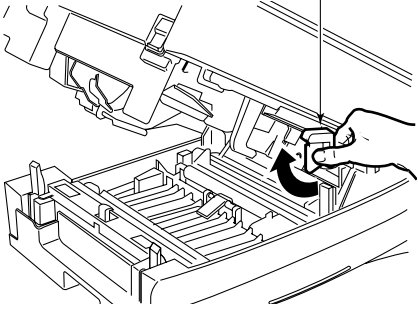
Step	Work	Checks and remarks																					
5	<p>Record the settings of 'PRIMARY' and 'IP_OFST' indicated on the label attached to the front of the drum unit on an appropriate piece of paper.</p> <p><b>Note:</b> _____                      You will need these settings in steps 4 and 6 of "Adjusting the Machine".                      _____</p>																						
6	<p>Insert the drum unit into the machine. When doing so, hold the drum unit horizontal in relation to the top unit, and act with care.</p> <ul style="list-style-type: none"> <li>• Be sure to slide in the drum unit until it butts against the rear end.</li> </ul> <p><b>Note:</b> _____</p> <ul style="list-style-type: none"> <li>• When mounting the drum unit, check to make sure that the drum unit releasing lever has been turned counterclockwise. (Otherwise, you would not be able to insert the drum unit into the machine.)</li> <li>• Take care not to touch the surface of the drum. Contact can affect copy images.</li> </ul>																						
7	<p>Turn the drum unit releasing lever clockwise to secure the drum unit in place.</p>																						
8	<p>Enter the date of installation of the drum unit and the counter reading on the label attached to the drum unit.</p> <table border="1" data-bbox="352 1742 871 1839"> <thead> <tr> <th data-bbox="352 1742 501 1794">date Datum</th> <th data-bbox="501 1742 730 1794">counter Zahler</th> <th data-bbox="730 1742 871 1794">notes Notiz</th> </tr> <tr> <th data-bbox="352 1794 501 1839">date</th> <th data-bbox="501 1794 730 1839">compteur</th> <th data-bbox="730 1794 871 1839">note</th> </tr> </thead> <tbody> <tr> <td data-bbox="352 1839 501 1883"> </td> <td data-bbox="501 1839 730 1883"> </td> <td data-bbox="730 1839 871 1883"> </td> </tr> <tr> <td data-bbox="352 1883 501 1928"> </td> <td data-bbox="501 1883 730 1928"> </td> <td data-bbox="730 1883 871 1928"> </td> </tr> <tr> <td data-bbox="352 1928 501 1973"> </td> <td data-bbox="501 1928 730 1973"> </td> <td data-bbox="730 1928 871 1973"> </td> </tr> <tr> <td data-bbox="352 1973 501 2018"> </td> <td data-bbox="501 1973 730 2018"> </td> <td data-bbox="730 1973 871 2018"> </td> </tr> <tr> <td data-bbox="352 2018 501 2056"> </td> <td data-bbox="501 2018 730 2056"> </td> <td data-bbox="730 2018 871 2056"> </td> </tr> </tbody> </table>	date Datum	counter Zahler	notes Notiz	date	compteur	note																
date Datum	counter Zahler	notes Notiz																					
date	compteur	note																					

Step	Work	Checks and remarks
9	<p>Turn the developing assembly locking lever clockwise.</p> <p><b>Note:</b> _____                      If the drum unit releasing lever was not turned clockwise in step 7, you would not be able to turn the developing assembly locking lever clockwise. Further, you would not be able to close the machine's top unit unless you turned the locking lever clockwise.                      _____</p>	<p>Developing assembly locking lever</p>  <p>The diagram illustrates the internal mechanism of a printer's top unit. A hand is shown turning a lever clockwise, which is labeled 'Developing assembly locking lever'. The lever is connected to a complex assembly of gears and other mechanical parts. A curved arrow indicates the direction of rotation.</p>

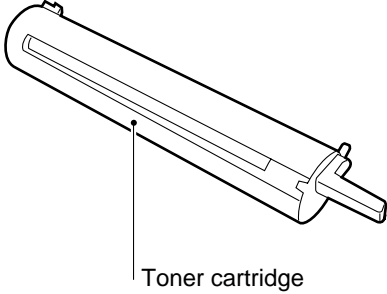
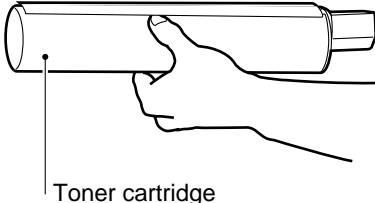
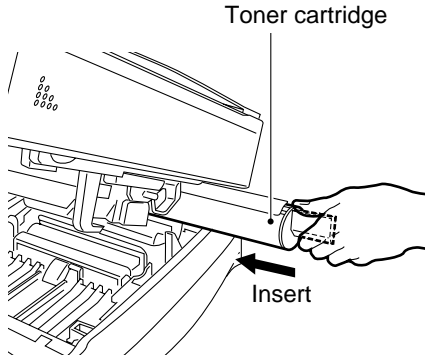
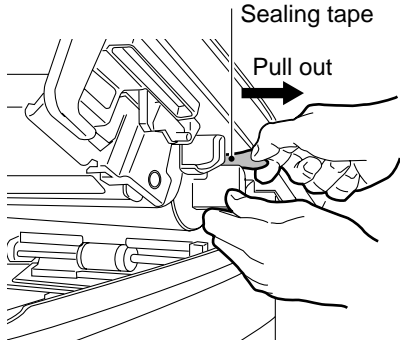
### 3. Installing the Toner Cartridge

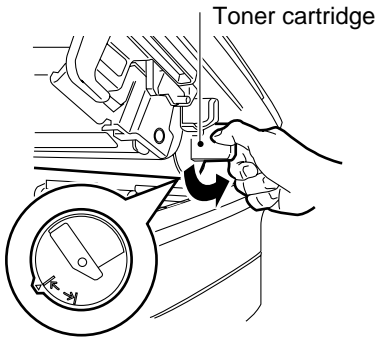
Step	Work	Checks and remarks
1	Prepare to insert a new toner cartridge.	 <p>Toner cartridge</p>
2	While holding the toner cartridge horizontal, shake it left and right so that the toner inside it is fully stirred and even.	<p>Shake to left and right</p>  <p>Toner cartridge</p>
3	Insert the toner cartridge into the machine. Be sure to hold it horizontal and work with care. Moreover, be sure to insert the toner cartridge until it butts against the rear end.	 <p>Toner cartridge</p> <p>Insert</p>
4	<p>Peel off the sealing tape of the toner cartridge. Press down on the toner cartridge and, while doing so, pick and pull the orange tab toward the front straight out.</p> <p><b>Caution:</b> Never dispose of any sealing tape into fire or an incinerator.</p> <p><b>Note:</b></p> <ul style="list-style-type: none"> <li>• Be sure to pull the sealing tape straight out.</li> <li>• Take care so that toner possibly adhering to the sealing tape will not stain your clothes.</li> </ul>	 <p>Sealing tape</p> <p>Pull out</p>

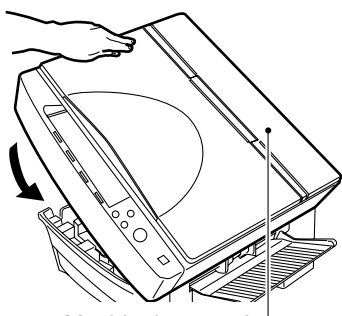
Step	Work	Checks and remarks
5	<p>Holding the grip of the toner cartridge, turn it counterclockwise until the cartridge locks into place.</p> <p><b>Note:</b></p> <ul style="list-style-type: none"> <li>• Be sure to turn the toner cartridge until it locks into place. If it is not locked, you will not be able to close the top unit.</li> <li>• If you cannot turn the grip of the toner cartridge, check to find out if the toner cartridge has been inserted fully to the rear end.</li> </ul>	 <p>Toner cartridge</p>
6	<p>Close the machine's top unit by pressing down firmly on the marked "  ".</p> <p><b>Note:</b></p> <p>If the toner cartridge has not been inserted to the rear end or has not been fully turned counterclockwise, you will not be able to close the top unit.</p>	 <p>Machine's top unit</p>

4. Attaching the ADF Auxiliary Tray (ADF type only)

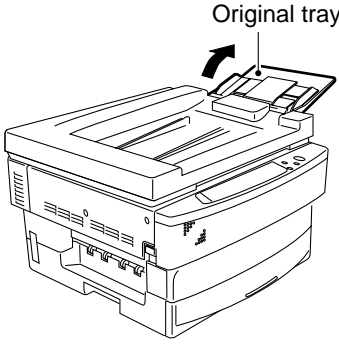
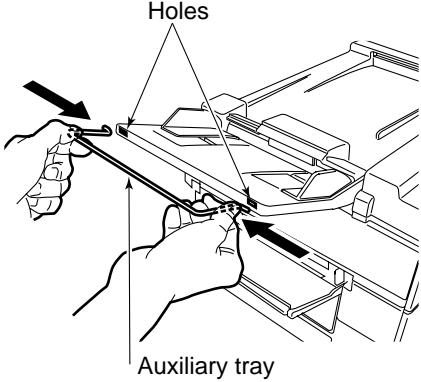
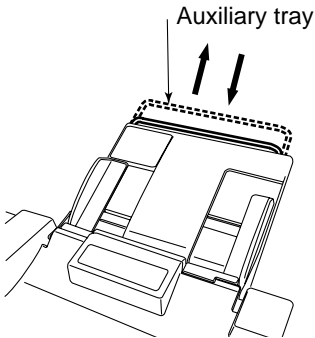
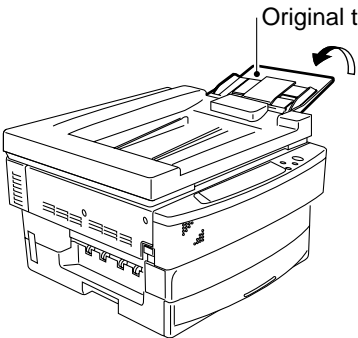
Step	Work	Checks and remarks
1	Open the original tray.	 <p>Original tray</p>
2	While bending the ADF auxiliary tray in the direction of arrows in the figure, insert it into the holes on the edge of the original tray.	 <p>Holes</p> <p>Auxiliary tray</p>
3	Slide in and out the auxiliary tray several times to make sure that it moves smoothly.	 <p>Auxiliary tray</p>
4	Close the original tray.	 <p>Original tray</p>

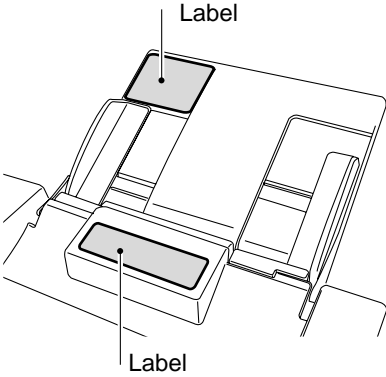
Step	Work	Checks and remarks
5	<p>All notations on the label attached to the ADF is in English. If a non-English language is needed, select the appropriate label from among those that come with the machine and stick it.</p>	 <p>The diagram shows a top-down view of the ADF mechanism. Two rectangular labels are shown being attached to the machine. One label is positioned on the upper part of the feeder, and the other is on the lower part. Both labels are shaded gray and have a small black dot in the center. Lines connect the text 'Label' to each of these dots.</p>

### 5. Connecting the Power Cord

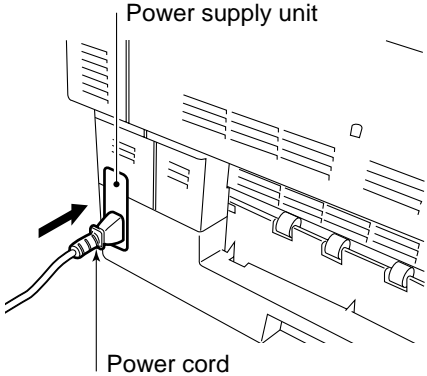
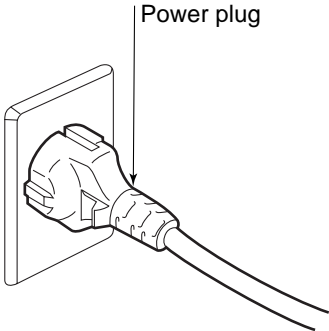
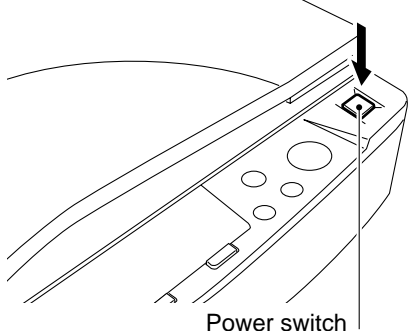
Step	Work	Checks and remarks
1	<p>Insert one end of the power cord to the machine's power supply unit.</p> <p><b>Note:</b></p> <p>Do not connect the power plug and turn on the power before completing "Setting Up the Machine" and "Installing the Drum Unit" to avoid damage to the machine.</p>	
2	<p>Connect the power plug to the power outlet.</p> <p><b>Caution:</b></p> <p>This machine is designed for use with a power source matching the power requirements shown on the marking label at the back of the machine. If you are unsure of the power source, check with your local power company.</p>	
3	<p>Turn on the power switch.</p> <ul style="list-style-type: none"> <li>The display will indicate '1'.</li> </ul>	

### 6. Adjusting the Machine

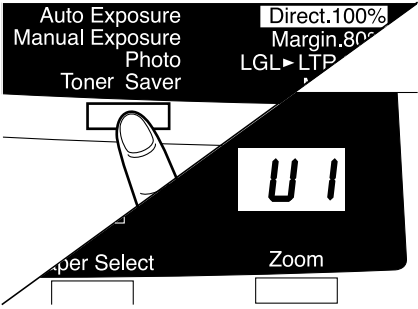
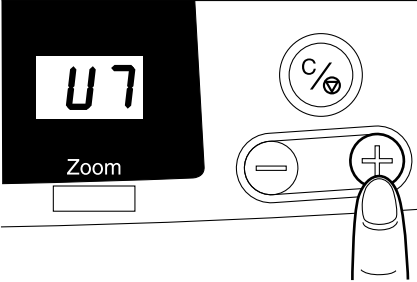
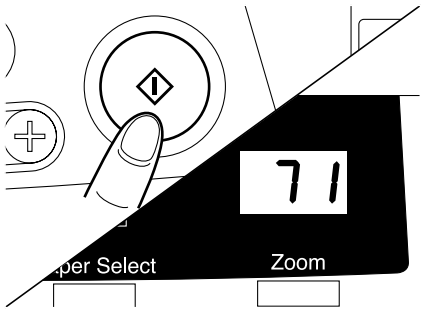
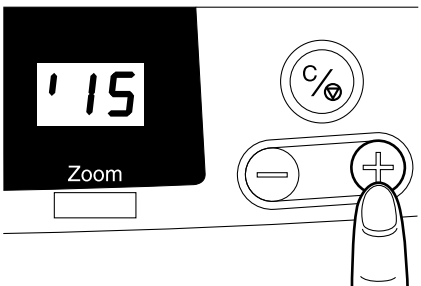
Step	Work	Checks and remarks
1	<p>Use "Installation/drum unit replacement mode" (U7) of the user mode to adjust the machine.</p> <p>To enter this mode, hold down the Exposure Mode Select key for 4 sec or more so that the display will indicate 'U1'.</p>	
2	<p>Enter "Installation/drum unit replacement mode" (U7).</p> <p>Press down the [+] key several times until the display indicates 'U7'.</p> <ul style="list-style-type: none"> <li>If you have inadvertently moved past the mode, press the [-] key to move back.</li> </ul>	
3	<p>Press the Copy Start (◊) key.</p> <ul style="list-style-type: none"> <li>The display will indicate '71' to indicate that "PRIMARY" adjustment mode has started.</li> </ul>	
4	<p>Adjust "PRIMARY"</p> <p>Using the [+] or [-] keys, enter the setting of "PRIMARY" you recorded in step 5 of "2. Installing the Drum Unit".</p> <ul style="list-style-type: none"> <li>During adjustment, the display will indicate "'15".</li> </ul>	

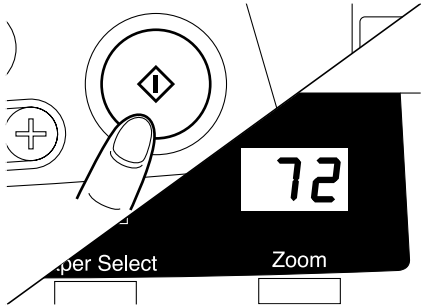
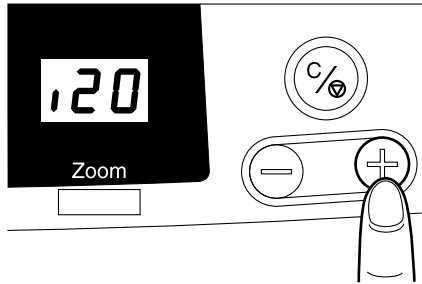
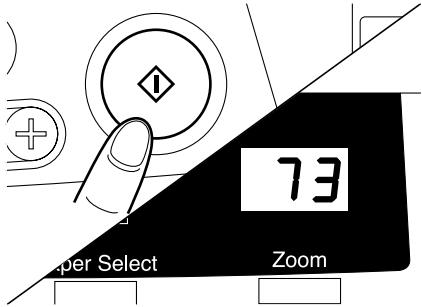
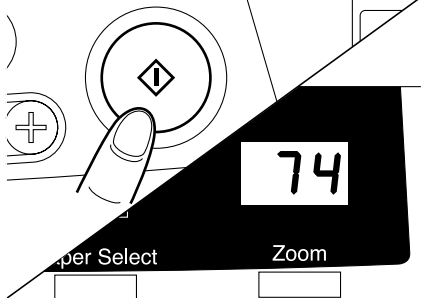

Step	Work	Checks and remarks
5	<p>Press the Copy Start (◀▶) key.</p> <ul style="list-style-type: none"> <li>The display will indicate '72' to indicate that "IP_OFST" adjustment mode has started.</li> </ul>	
6	<p>Adjust "IP_OFST"</p> <p>Using the [+] or [-] keys, enter the setting of "IP_OFST" you recorded in step 5 of "2. Installing the Drum Unit".</p> <ul style="list-style-type: none"> <li>During adjustment, the display will indicate "120".</li> </ul>	
7	<p>Press the Copy Start (◀▶) key.</p> <ul style="list-style-type: none"> <li>The display will indicate '73'.</li> </ul>	
8	<p>Press the Copy Start (◀▶) key.</p> <ul style="list-style-type: none"> <li>The display will indicate '74'.</li> </ul>	

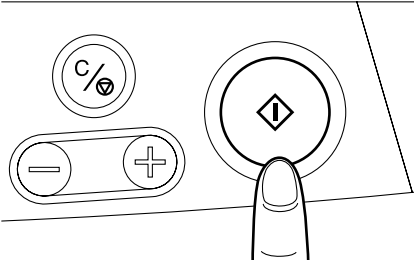
Step	Work	Checks and remarks
9	<p>Press the Copy Start (◀▶) key.</p> <ul style="list-style-type: none"> <li>The machine will start to stir the toner and start auto adjustment. The display will indicate '1' when the machine finishes installation/drum unit replacement mode.</li> <li>Stirring of toner and auto adjustment take about 1 minute. Make use of this period by mounting the copy tray as follows:</li> </ul>	

### 7. Installing the Copy Tray

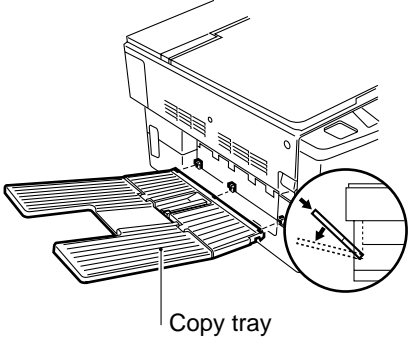
Step	Work	Checks and remarks
1	<p>Attach the copy tray into the machine.</p> <p>Fit the copy tray by matching its grooves over the three protrusions on the machine's left side.</p>	

### 8. Sticking the Label

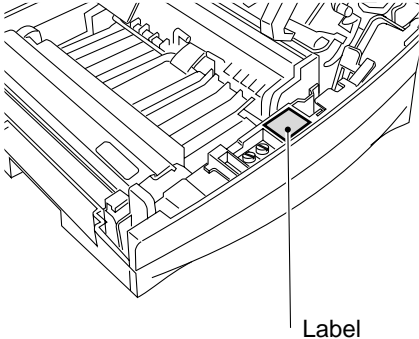
Step	Work	Checks and remarks
1	Open the machine's top unit; then, select the appropriate label from among those that come with the machine and stick it.	

### 9. Checking the Operation

Step	Work	Checks and remarks
1	Set the Test Sheet on the copyboard glass, and check copying operation.	<ul style="list-style-type: none"> <li>• Make sure there is no abnormal noise.</li> <li>• Make sure that as many copies as specified are made normally.</li> </ul>
2	Clean the machine's exterior and the area around it.	

## B. Placing Copy Paper

### 1. Universal Cassette

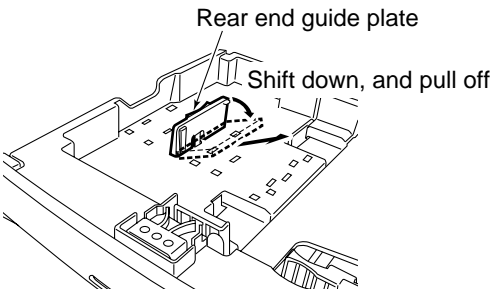
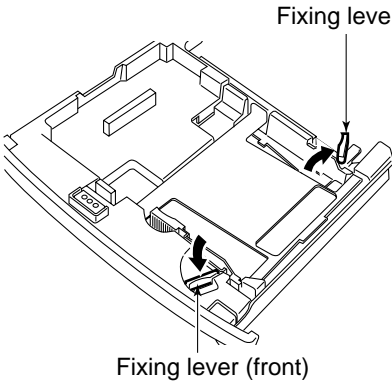
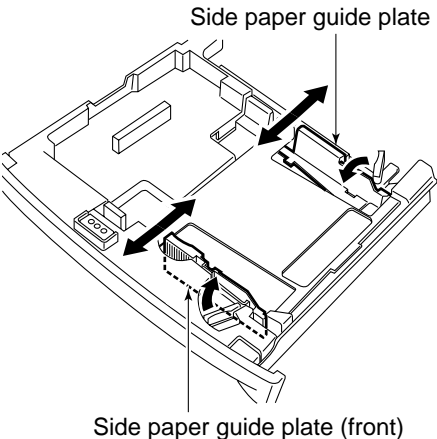
Step	Work	Checks and remarks
1	Take out the cassette from the machine, and remove the protective members and the label.	
2	Remove the rear guide plate as shown, and mount it back to suit the size of the copy paper to be used.	 <p>Rear end guide plate Shift down, and pull off</p>
3	Turn the fixing lever (front, rear) of the side paper guide plate as shown, and unlock the side paper guide plate.	 <p>Fixing lever (rear) Fixing lever (front)</p>
4	Slide the side paper guide plate to suit the width of the copy paper to be used; then, turn the fixing lever as shown to lock the side paper guide plate in place.	 <p>Side paper guide plate (rear) Side paper guide plate (front)</p>

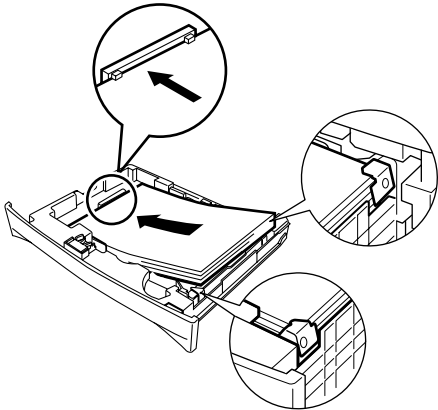
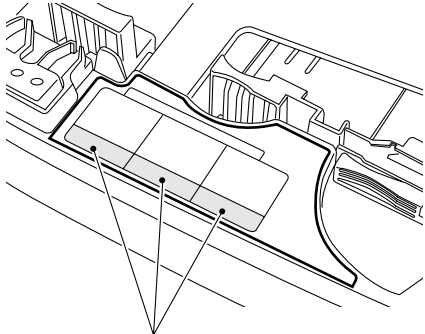
Step	Work	Checks and remarks
5	Place copy paper in the cassette, and set the cassette into the machine.	
6	All text on the label attached to the cassette is English. If you need to replace it with a non-English label, select the appropriate one from among those packaged with the machine, and attach it.	 <p data-bbox="1010 1182 1310 1211">Language label for cassette</p>

2. 250-Sheet/500-Sheet Cassette

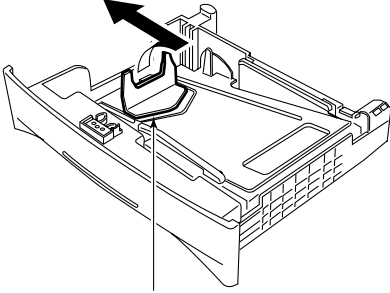
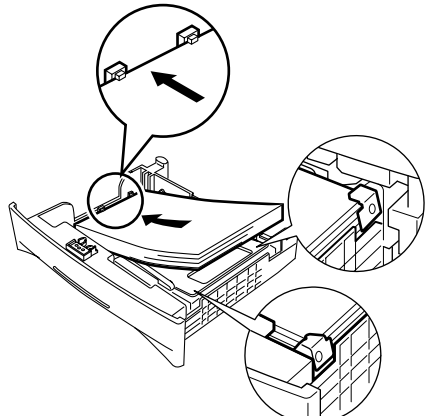
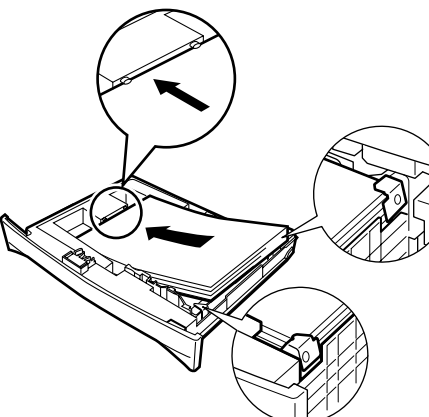

Step	Work	Checks and remarks
1	Take out the cassette from the machine, and remove the protective member.	
2	Slide the rear end paper guide plate as shown to match the size of the paper to be used.  <b>Caution:</b> This step applies to the 500-sheet cassette (LTR/LGL) only.	 <p>Rear end guide plate</p>
3	Place copy paper in the cassette; then, set the cassette in the machine.	 <p>500-sheet cassette</p>  <p>250-sheet cassette</p>

### III. MOVING THE MACHINE

If you need to move the machine by truck or any other means of transportation after installation, be sure to perform the following:

**Caution:**

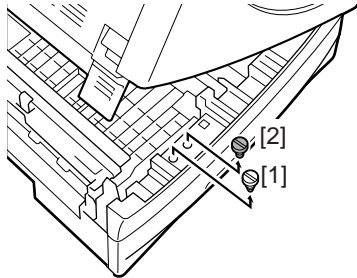
Before starting the following work, check to make sure that the machine is not too hot. If it is, as immediately after continuous copying, you may not be able to carry out step 8, in which the shipping attachment is replaced.

Step	Work	Checks and remarks
1	Turn on the power, and press the Default Ratio key to select 70%.	
2	Press the Paper Select key to select the manual feed tray; then, press the Copy Start key without placing any paper on the manual feed tray.	The count/ratio indicator will indicate '70'.
3	Turn off the power switch, and disconnect the power plug from the outlet.	
4	Pull the open/close lever found on the left of the machine, and open the machine's top unit.	
5	Take out the shipping attachments [1] and [2] stored in the machine's bottom unit. 	
6	Detach the copy tray.	
7	Press down on the  marking on the machine's top unit to fully close the machine.	

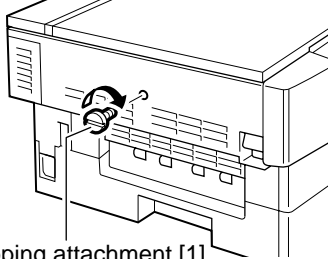
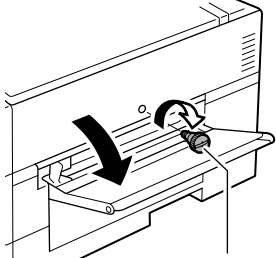
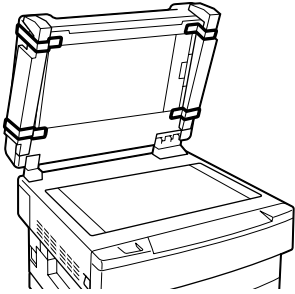
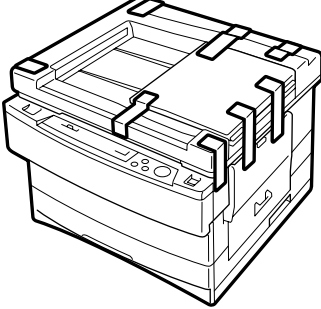
Step	Work	Checks and remarks
8	<p>Fit the shipping attachments [1] and [2] detached in step 5 back to the machine.</p>  <p>Shipping attachment [1]</p>  <p>Shipping attachment [2]</p>	
9	<p>Tape the machine's top unit in place to prevent it from opening.</p>	
10	<p>Place A4/LGL copy paper on the copyboard glass, and close the copyboard cover; then, tape it in place. (Copyboard type only)</p> <p>Raise the ADF. Then, place two parts used as packaging so that they fit closely around both sides and the front of the ADF, as shown in the diagram, and secure them with tape. (ADF type only)</p>	
11	<p>Gently lower the ADF and secure the main unit by taping in eight places, as shown in the diagram. (ADF type only)</p> <p>Pack the machine, using the original packing material and box.</p> <p>Or tape the machine's top in place so that it will not open while in transit.</p>	



---

# CHAPTER 10

---

## MAINTENANCE AND SERVICING

---

I. PERIODICALLY REPLACED PARTS .....	10-1	II. DURABLES AND CONSUMABLES .....	10-1
		III. SCHEDULED SERVICING .....	10-1



## **I. PERIODICALLY REPLACED PARTS**

The machine does not have parts which must be replaced on a periodical basis.

## **II. DURABLES AND CONSUMABLES**

The machine does not have items designated as durables or consumables.

## **III. SCHEDULED SERVICING**

The machine does not have any parts which require scheduled servicing.



---

# CHAPTER 11

---

## TROUBLESHOOTING

---

I.	MAINTENANCE AND INSPECTION .....	11-3	B.	Faulty Feeding .....	11-80
A.	Image Adjustment Basic Procedure .....	11-3	VI.	ARRANGEMENT AND FUNCTIONS OF ELECTRICAL PARTS .....	11-81
B.	Points to Note for Servicing .....	11-4	A.	Sensors and Solenoids ....	11-81
II.	STANDARDS AND ADJUSTMENTS .....	11-5	B.	Switches .....	11-82
A.	Mechanical .....	11-5	C.	Lamp, Heater, Motor, Etc.	11-83
B.	ADF .....	11-30	D.	PCBs .....	11-84
C.	Electrical .....	11-41	E.	ADF .....	11-85
III.	TROUBLESHOOTING IMAGE FAULTS .....	11-52	F.	Variable Resistors (VR) and Check Pins by PCB .....	11-86
A.	Making Initial Checks .....	11-52	VII.	SERVICE MODE .....	11-88
B.	Sample Image Faults .....	11-56	A.	Outline .....	11-88
C.	Troubleshooting Image Faults .....	11-57	B.	Using Service Mode .....	11-88
IV.	TROUBLESHOOTING MALFUNCTIONS .....	11-65	C.	Adjustment Mode (30) .....	11-91
A.	Troubleshooting Malfunctions .....	11-65	D.	Operation/Inspection Mode (40) .....	11-92
V.	TROUBLESHOOTING FEEDING PROBLEMS .....	11-77	E.	Machine Settings Mode (50) .....	11-93
A.	Copy Paper Jam .....	11-77	F.	Counter Mode (60) .....	11-93
			VIII.	SELF DIAGNOSIS .....	11-94



## Guide to the Troubleshooting Procedure

This chapter provides troubleshooting instructions in the form of tables prepared based on generally found flow charts. Study the following for an idea of how to use them:

AC power is absent.

Cause	Step	Checks	YES/NO	Action
Power plug	1	Is the power plug connected to the power outlet?	NO	Connect the plug.
Covers	2	Are the front door and delivery cover closed fully?	NO	Close the door or the cover.
Power source	3	Is the rated voltage found at the power outlet?	NO	Inform the user that
-----	4	Is the rated voltage present between J1-1 and -2? (J1 is found near the power cord mount.)	YES	Go to step 6.

(Rest omitted.)

- To find out the cause (possible fault) of a specific problem, see the "Cause" column. If the problem is "AC power is absent," you may suspect that the power plug is disconnected, covers are not closed fully, or power is absent at the main source.
- If you want to find out the checks to make or action to take, go through the steps: answer the questions under "Checks"; if yes, take the action shown. Otherwise, go to the next step and make the indicated checks.

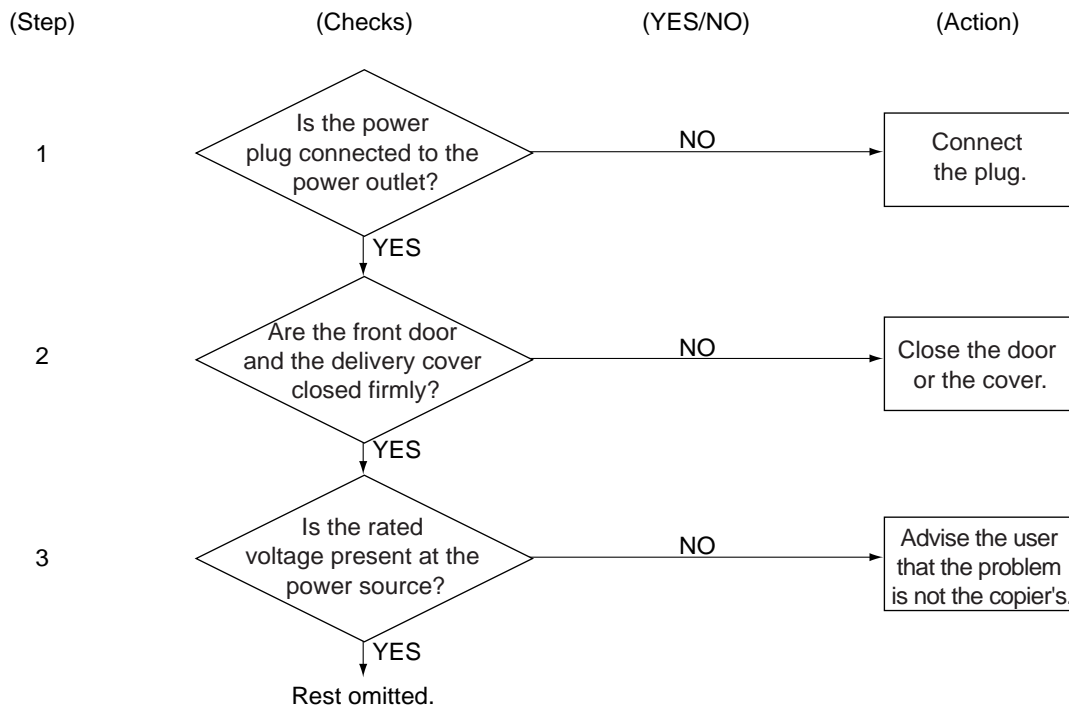

- Often, you will find the following instructions when checking the voltage using a meter: "measure the voltage between J109-1 (+) and -2 (-) on the DC controller PCB." The symbol "+" indicates the terminal to which you are expected to connect the positive probe of the meter and "-", the negative probe.

example:

J109-1 (+) ..... Connect the positive probe.

J109-2 (-) ..... Connect the negative probe.



# I. MAINTENANCE AND INSPECTION

## A. Image Adjustment Basic Procedure

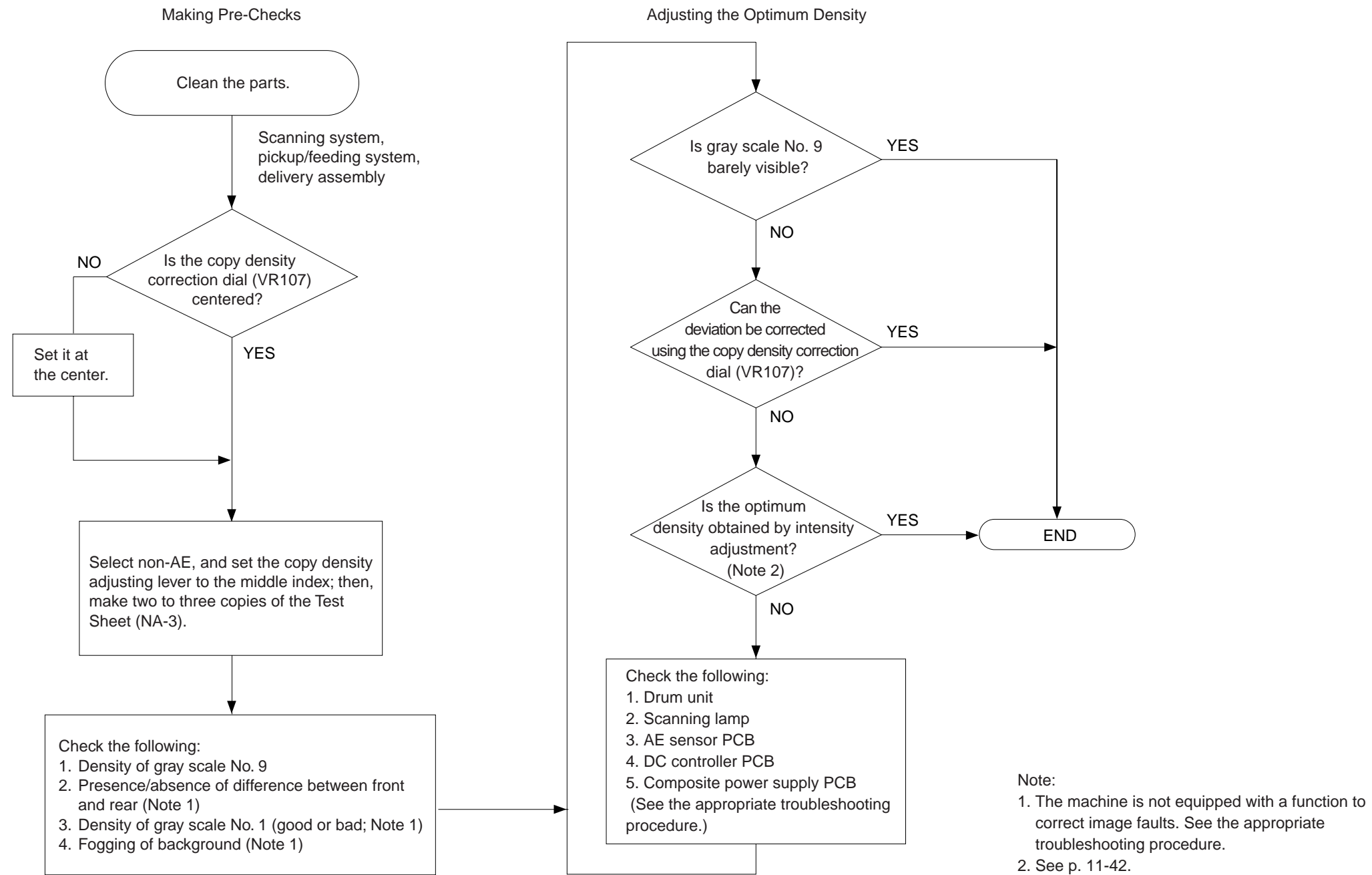

## B. Points to Note for Servicing

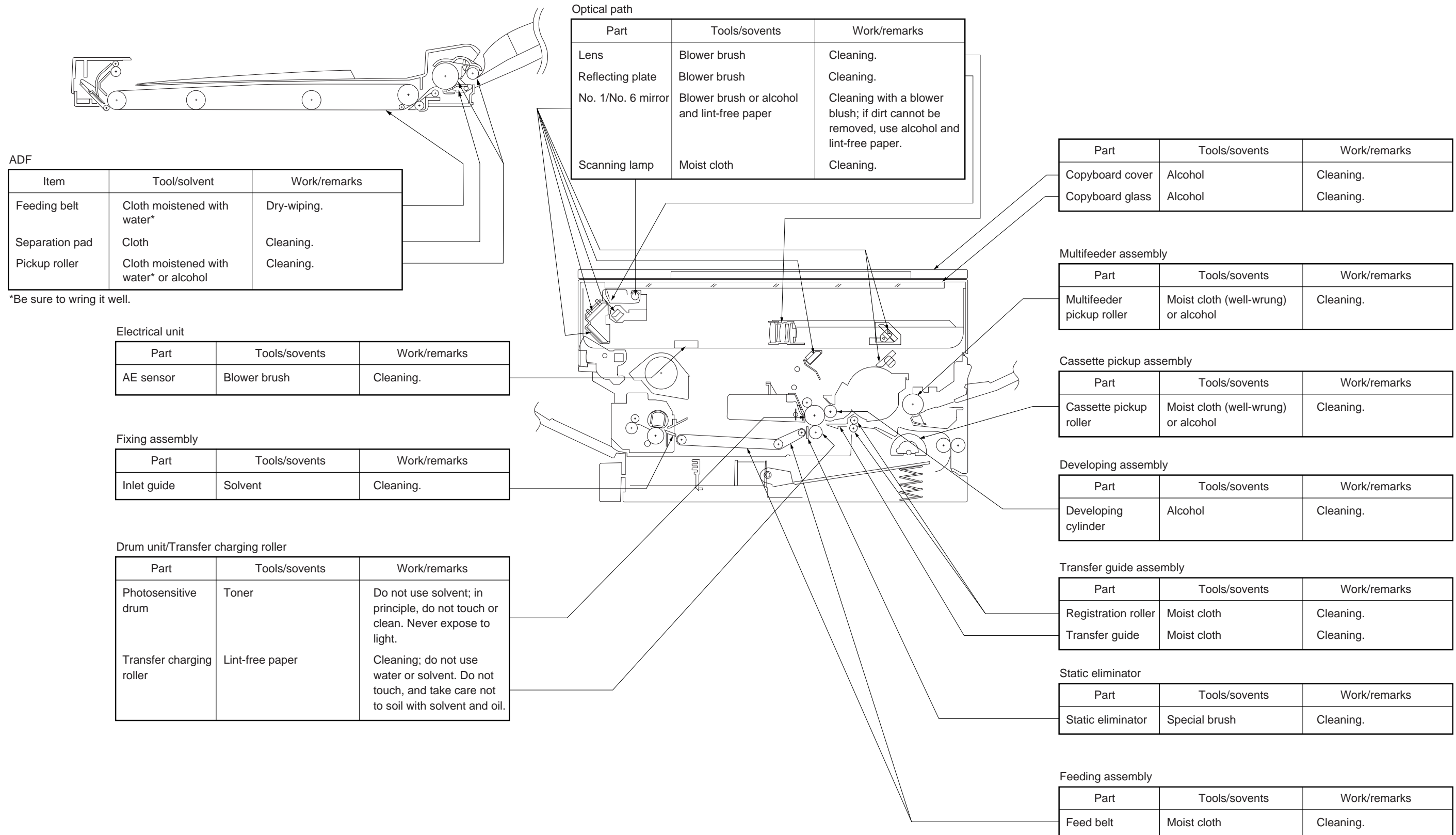

## II. STANDARDS AND ADJUSTMENTS

### A. Mechanical

#### 1. Copier

##### a. Leading Edge Non-Image Width

Make adjustments so that the leading edge non-image width is  $2.0 \pm 1.5$  mm when the Test Sheet is copied in Direct.

#### Caution:

If you have performed this adjustment, be sure to adjust the image leading edge margin.

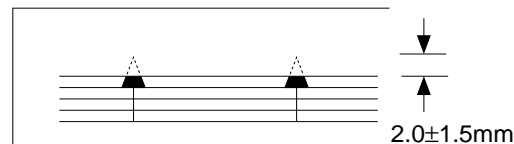

Figure 11-201

#### Making Adjustments

- 1) Select '31' in service mode.
  - The display will indicate '31'.
- 2) Press the Copy Start key.
  - The existing setting will flash.
- 3) Change the setting by the +/- key.
  - The setting may be between 0 and 99.
  - For each '1', the non-image width will change by 0.24 mm.
- 4) Press the AE key.
  - The setting will stop flashing and will remain on, indicating that it has been stored in memory.
- 5) As necessary, press the Clear/Stop key once to return to item selection; or, press it once again to end service mode.

Relationship between Setting and Leading Edge Non-Image Width

Setting	Leading edge non-image width
Higher	Increases
Lower	Decreases

Table 11-201

b. Image Leading Edge Margin (registration activation timing)

Make adjustments so that the leading edge margin is  $2.5 \pm 1.5$  mm when the Test Sheet is copied.

**Caution:**

Be sure to check that the leading edge non-image width is as indicated before performing this adjustment.

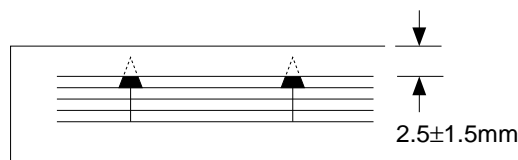

Figure 11-202

**Making Adjustments**

- 1) Select '30' in service mode.
  - The display will indicate '30'.
- 2) Press the Copy Start key.
  - The existing setting will flash.
- 3) Change the setting using the +/- key.
  - The setting may be between 0 and 99.
  - The setting will change by 0.24 mm in terms of margin for each '1'.
- 4) Press the AE key.
  - The setting will stop flashing and will remain on, indicating it has been stored in memory.
- 5) As necessary, press the Clear/Stop key once to return to item selection; or, press it once again to end service mode.

Relationship between Settings and Image Leading Edge Margin

Setting	Image leading edge margin
Higher	Decreases
Lower	Increases

Table 11-202

- c. Adjusting the Mirror Position (optical length between No. 1 mirror and No. 2 mirror)  
 If you have replaced the scanner drive cable, you must adjust the mirror position, by changing the position of the cable retainer of the No. 1 mirror mount.

## Reference:

1. As more and more copies are made, the cable tends to become slack, requiring adjustment.
2. If the optical length between the No. 1 mirror and the No. 2 mirror is not correct, the horizontal reproduction ratio will be wrong, causing poor sharpness or blurred images.

- 1) Fit the mirror positioning tool (FY9-3009) as shown.

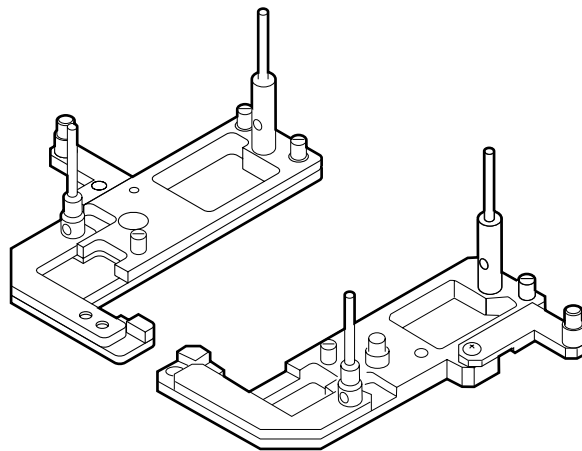

Figure 11-203

- 2) Remove the copyboard glass.  
 (See Chapter 7.III.C.1. "Removing the Copyboard Glass.")
- 3) Loosen the screws used to secure the cable retainer at the rear and the front of the No. 1 mirror mount [1].

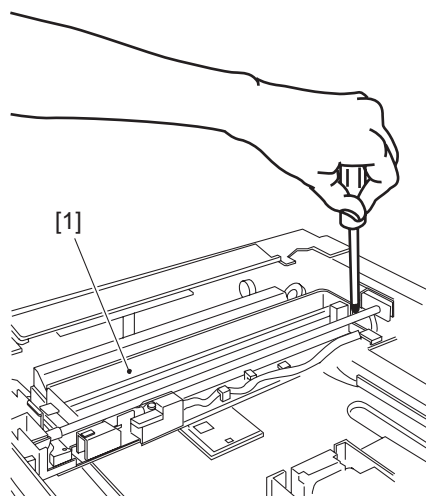

Figure 11-204

- 4) Turn the cable drive pulley [3] so that the three shafts [2] of the mirror positioning tool for the front and the rear may be arranged as shown.

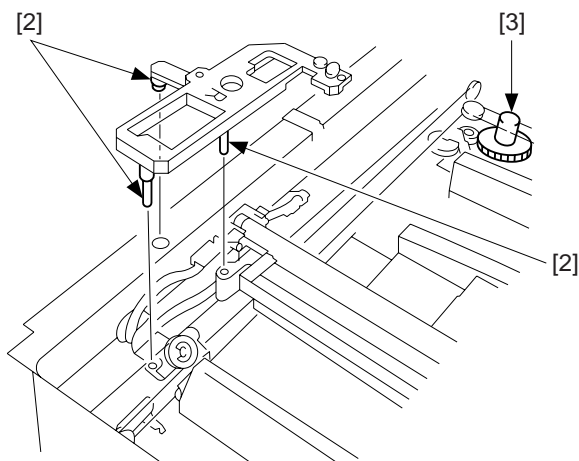

Figure 11-205 (rear)

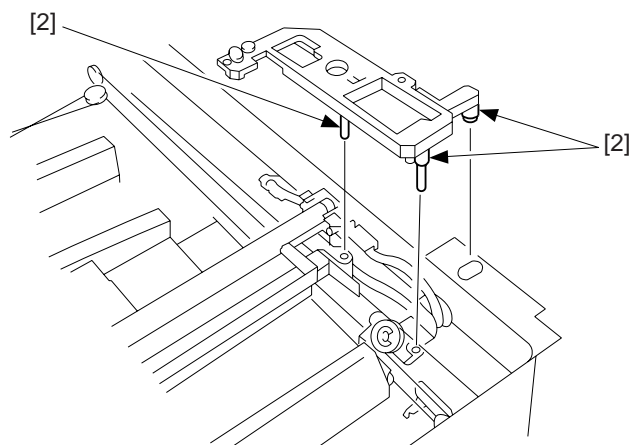
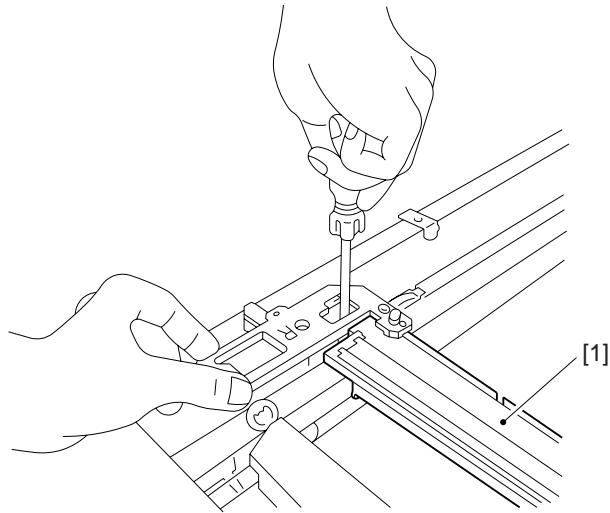
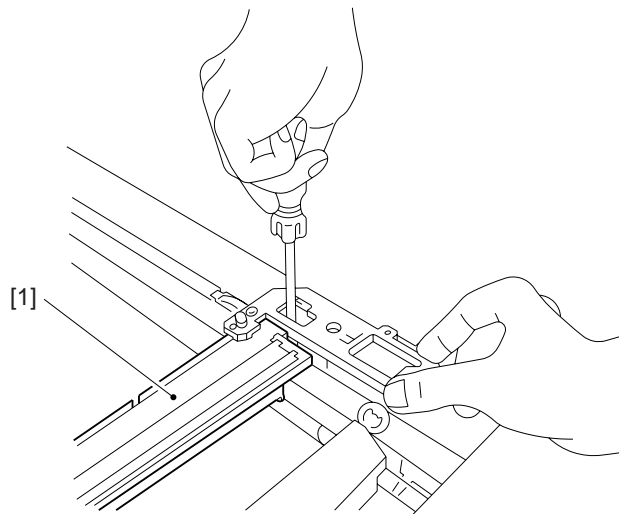

Figure 11-206 (front)

- 5) While keeping the condition of 4), tighten the positioning screw at the rear and the front of the No. 1 mirror mount [1].



**Figure 11-207 (rear)**



**Figure 11-208 (front)**

d. Checking the Force of the Cassette Spring

If the force of the spring used to hold up the holding plate of the cassette is not correct, pickup faults or the like can occur.

If a fault is suspected, check the force of the spring using a spring gauge (CK-0054), and replace the spring if it is not as indicated:

Standard:  $970 \pm 150$  g

Making Measurements

Push the spring gauge against the middle of the spring as shown, and check to make sure that the reading of the spring gauge is  $970 \pm 150$  g when the holding plate is 18 mm away from the bottom of the cassette.

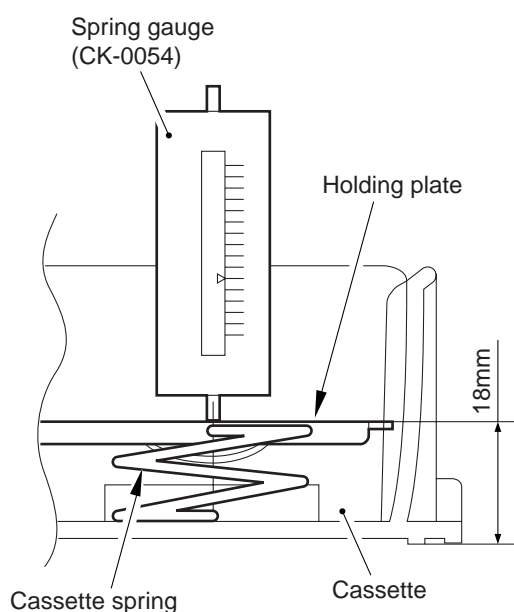

Figure 11-209



e-1. Routing the Scanner Drive Cable

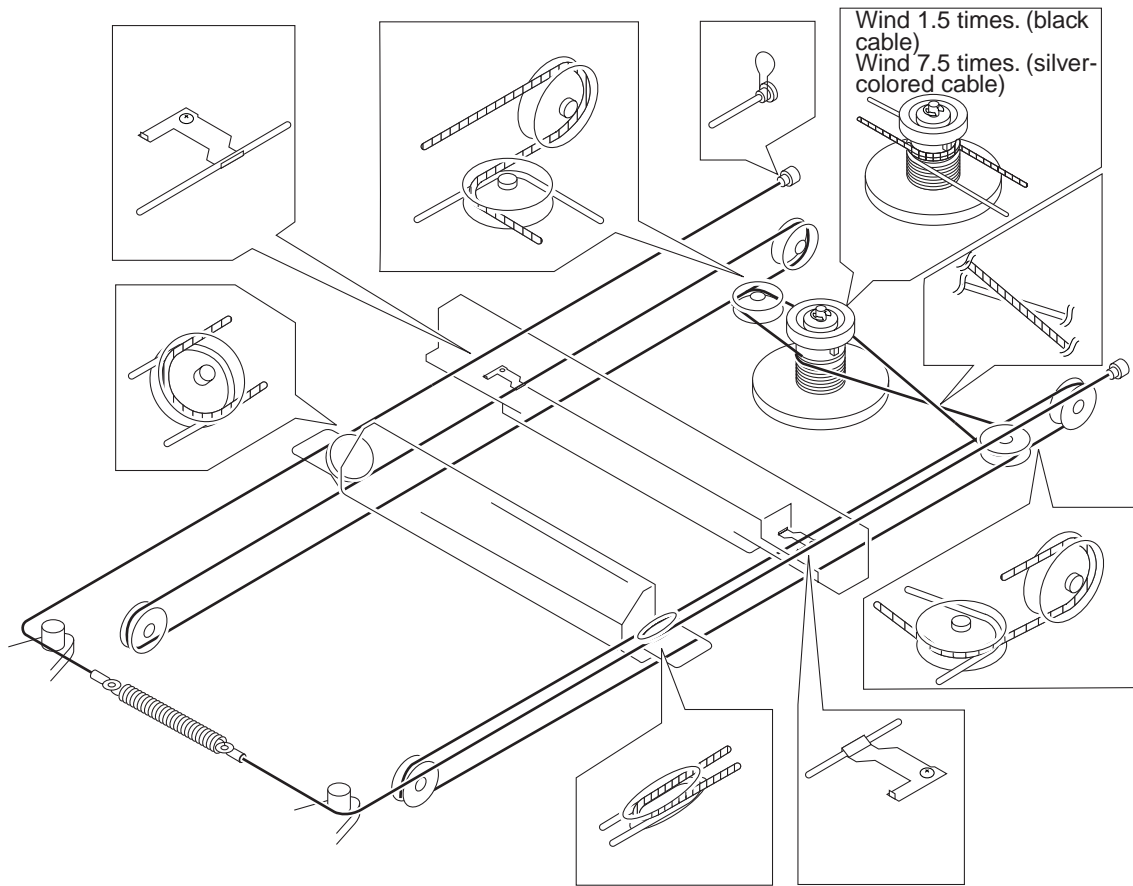

Figure 11-210

e-2. Routing the Scanner Drive Cable

1. Before Starting the Work

Prepare the following:

- Mirror positioning tool (FY9-3009)
- Cable clip (FY9-3017)
- Adhesive tape

1) Set the mirror positioning tool as shown.

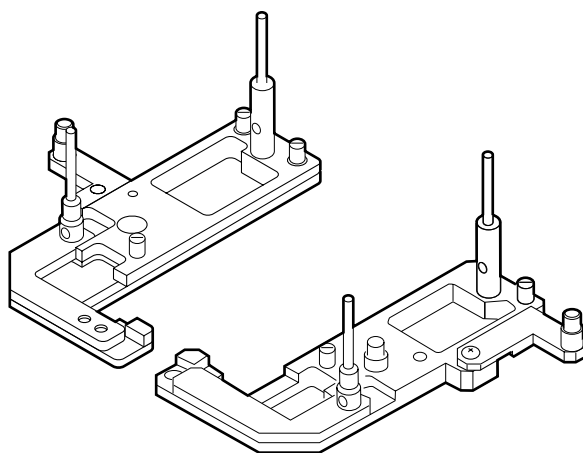

Figure 11-211

- 2) Prepare about five strips of adhesive tape (each one about 20 x 50 mm).
- 3) Remove the copyboard glass.  
(See Chapter 7.III.C.1. “Removing the Copyboard Glass.”)
- 4) Disconnect the connectors (J101, J131) [1] from the DC controller PCB.

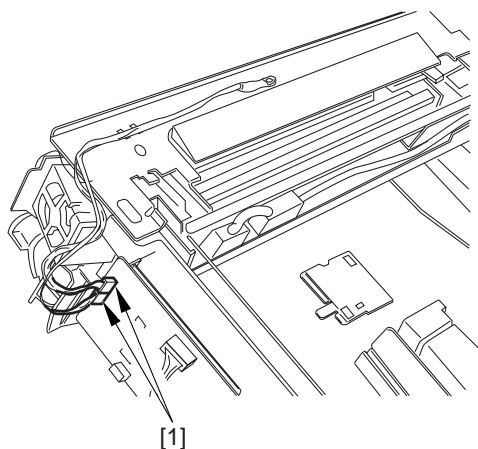
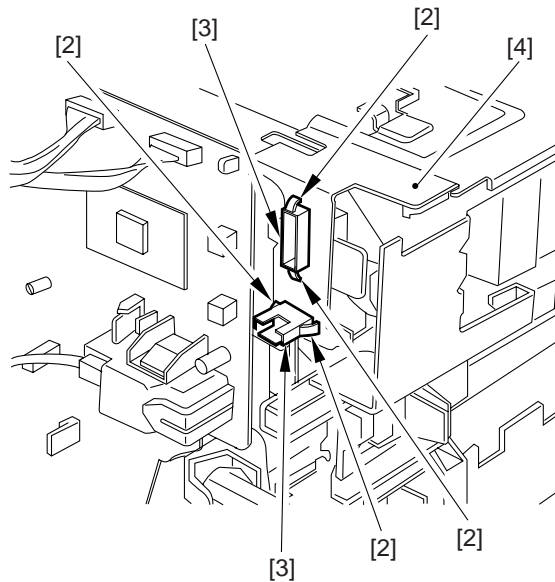

Figure 11-212

- 5) If the machine is equipped with an ADF, free the hook [2], and disconnect the two relay connectors [3] from the left upper stay [4].



**Figure 11-213**

- 6) Remove the three screws [5], and detach the left upper stay [4].

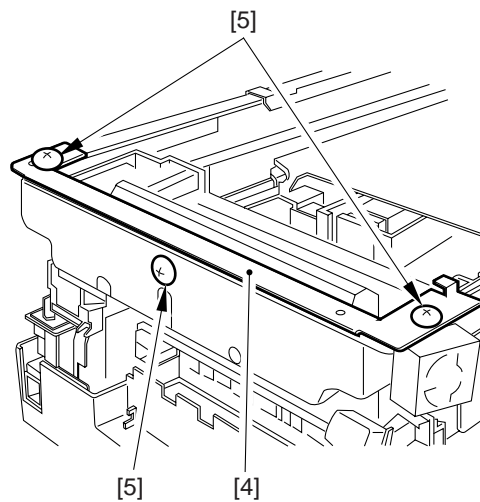

**Figure 11-214**

7) Remove the four screws [7], and detach the lens cover [8].

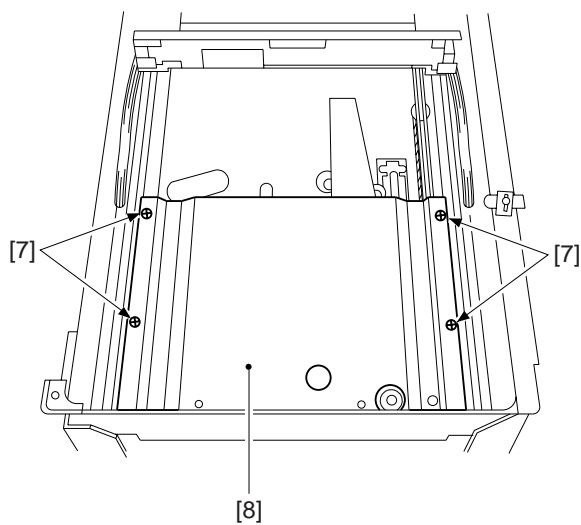

Figure 11-215

2. Routing the Reversing Cable

- 1) Wind the reversing cables (silver-colored) [2] on the cable drive pulley [1] 7.5 times with the longer of the two on top; then, secure it in position with a cable clip [3].

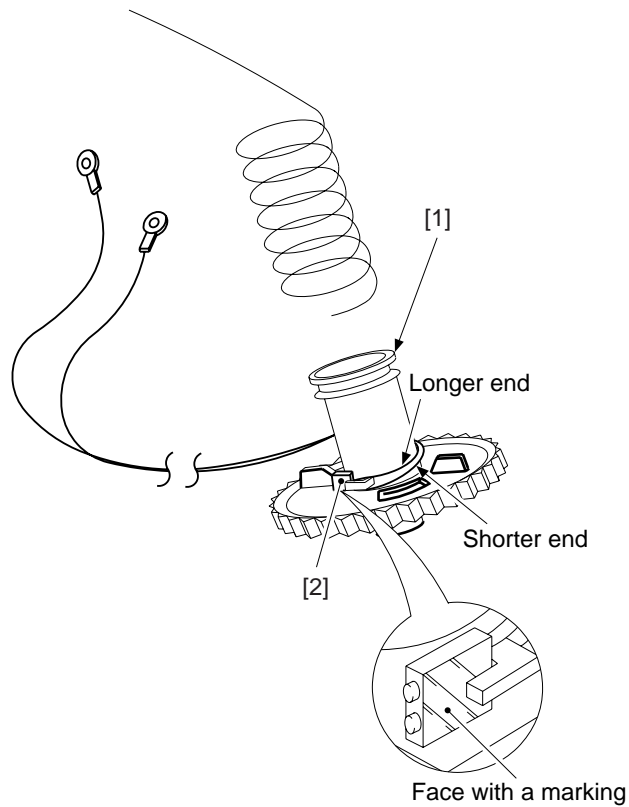

Figure 11-216

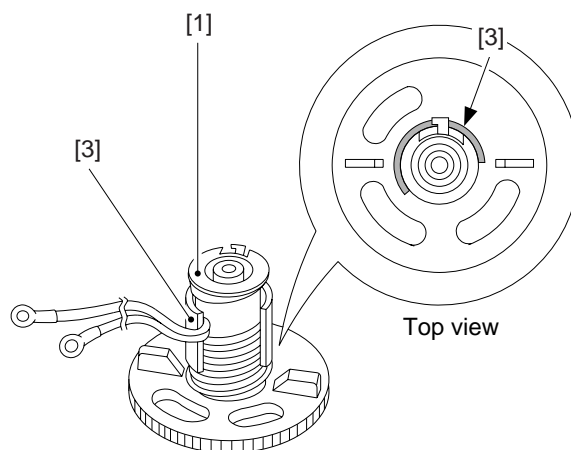

Figure 11-217

- 2) Put the cable drive pulley [1] into the shaft [4], and secure it in position with an E-ring [5].  
When putting the cable drive pulley into the shaft, be sure that the hook is at the front.

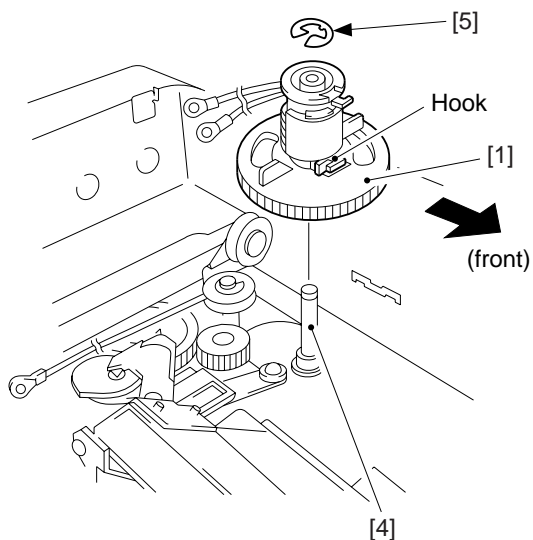

Figure 11-218

- 3) Hook the shorter end [6] on the pulley [7].

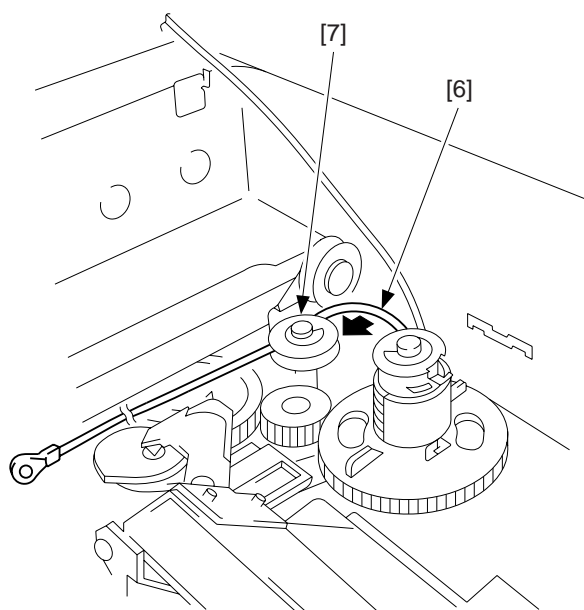
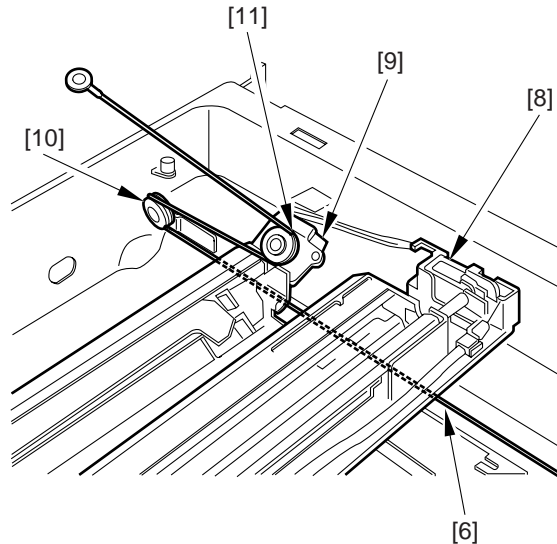

Figure 11-219

- 4) Lead the shorter end [6] under the No. 1 mirror mount [8] and the No. 2/3 mirror mount [9]; then, hook it on the left rear pulley [10] and the pulley [11] of the No. 2/3 mirror mount.



**Figure 11-220**

- 5) After fitting the shorter end [6] on the cable hook [12], secure its end with adhesive tape [13]. Be sure that the secured end of the cable is found where the hole in the left side plate and the tip of the cable matches.

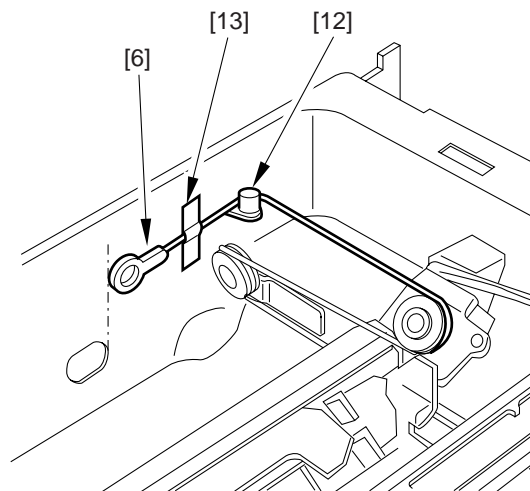

**Figure 11-221**

- 6) Lead the longer end [14] along the cable drive pulley, and hook it on the pulley [15] on the right front side.

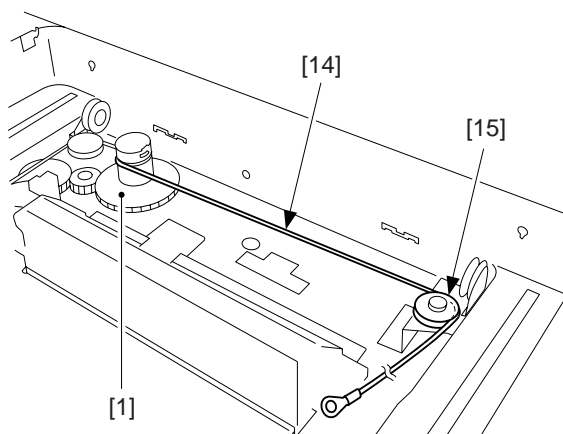

Figure 11-222

- 7) Lead the longer end [14] under the No. 1 mirror mount [8] and the No. 2/3 mirror mount [9]; then, hook it on the pulley [16] on the left front side and the pulley [17] of the No. 2/3 mirror mount.

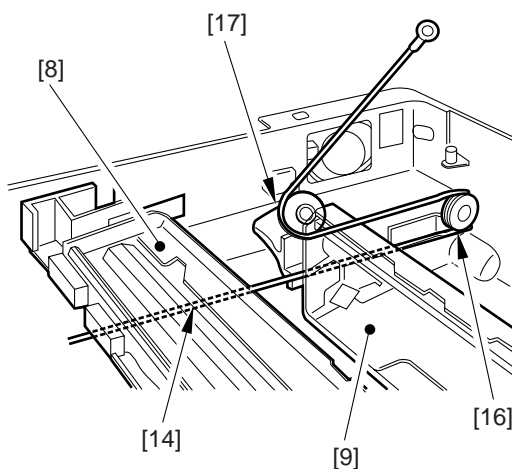

Figure 11-223



- 8) Hook the longer cable [14] on the cable hook [18]; then, secure its end to the left side with adhesive tape [19].  
Be sure that the secured end of the cable is found where the hole in the left side plate and the tip of the cable matches.

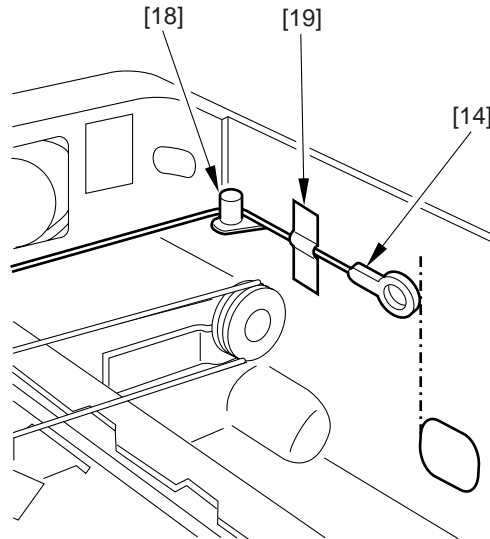

Figure 11-224

3. Routing the Forwarding Cable

- 1) Fit the longer end forwarding cable (black) [2] on the top hook of the cable drive pulley [1], and wind it 1.5 times. Then, secure the shorter end [3] as shown with adhesive tape [4].

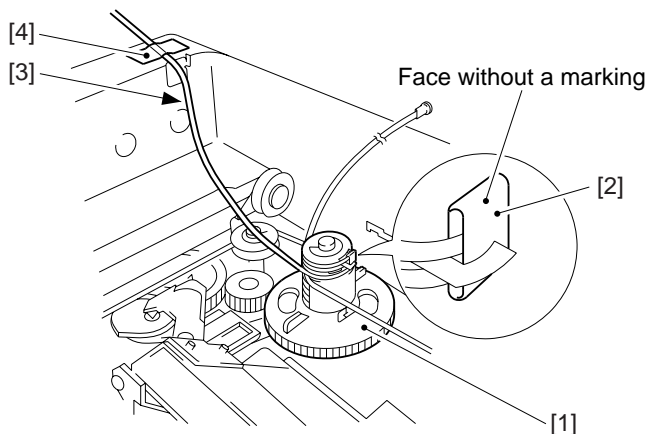

Figure 11-225

- 2) Lead the longer end [5] along the cable drive pulley [1] as shown, and hook it on the pulley [6] on the right front side.

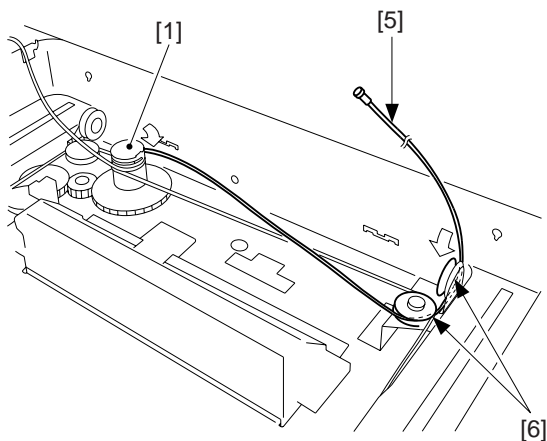
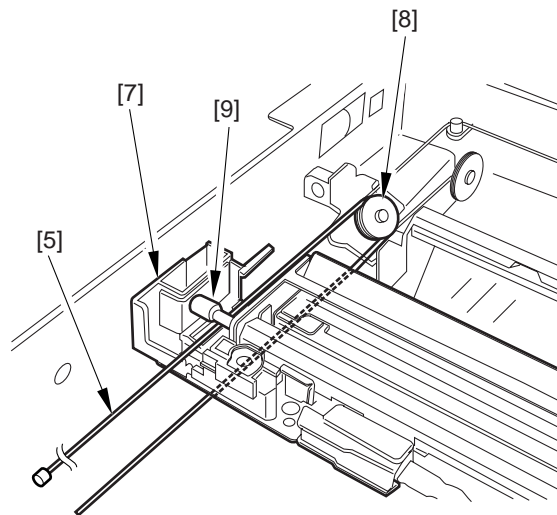

Figure 11-226

- 3) Lead the longer end [5] under the No. 1 mirror mount [7]; then, hook it on the pulley [8] of the No. 2/3 mirror mount, and lead it between the No. 1 mirror mount [7] and the scanning lamp [9].



**Figure 11-227**

- 4) Hook the end of the longer end [5] on the hole [10] on the right side.

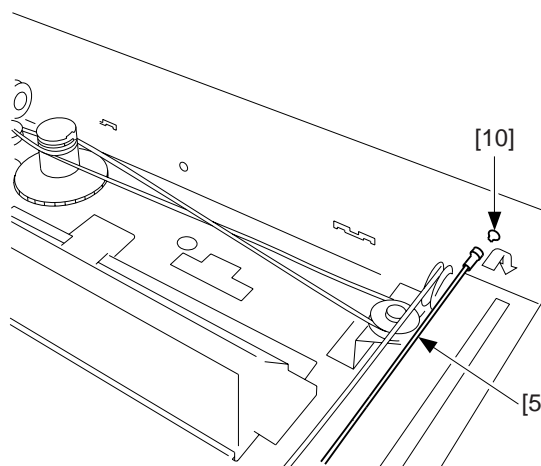

**Figure 11-228**

- 5) Free the shorter end [3], and hook it on the pulley [11] on the right rear side.

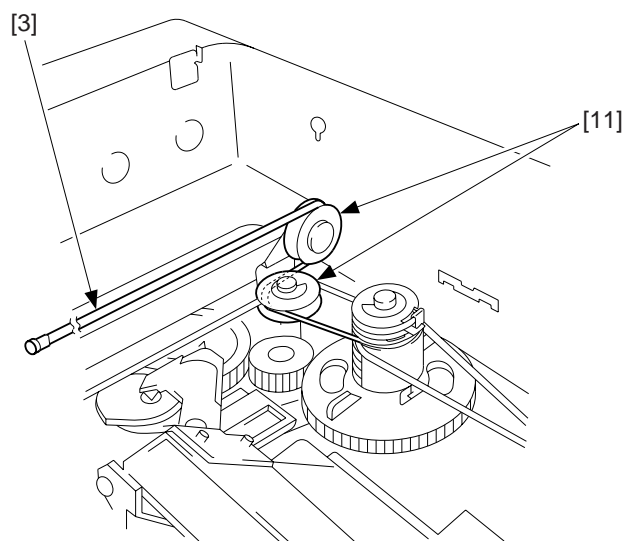

Figure 11-229

- 6) Lead the shorter end [3] under the No. 1 mirror mount [7], and hook it on the pulley [12] of the No. 2/3 mirror mount as shown; then, lead it between the No. 1 mirror mount [7] and the scanning lamp [9].

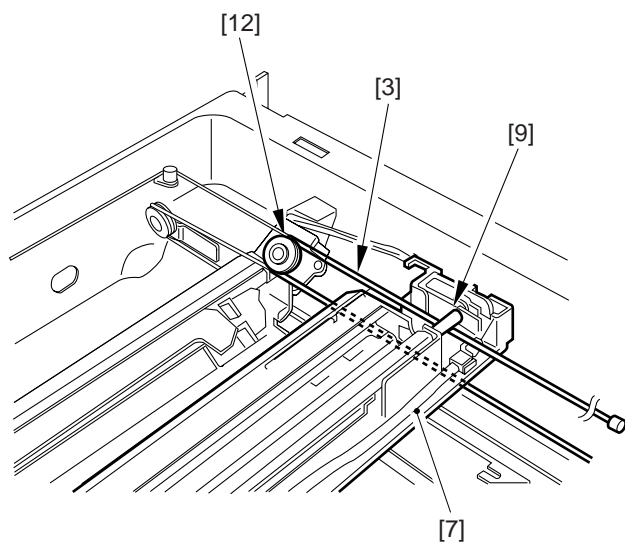

Figure 11-230

- 7) Hook the end of the shorter end [3] on the hole [13] on the right side.

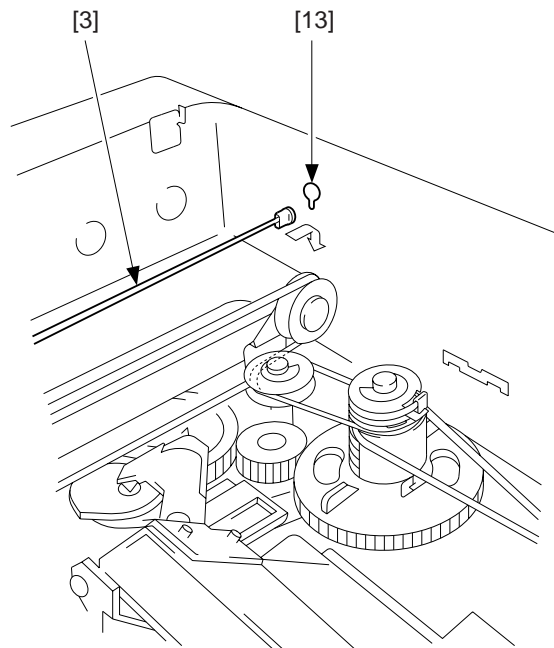

Figure 11-231

- 8) Free the shorter end [3] and the longer end [5] (reversing cable), and connect both with a spring [14]; then, fit the stopper [15].

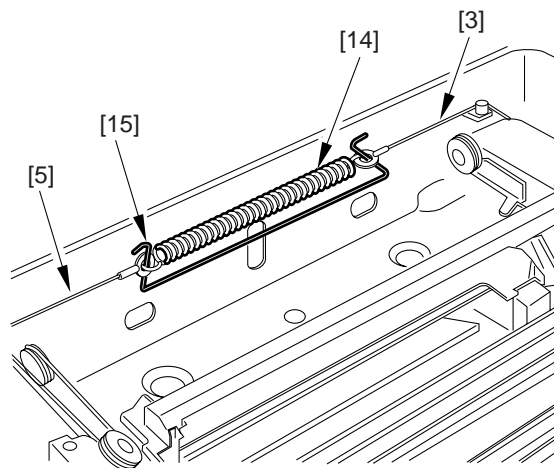

Figure 11-232

- 9) Detach the pulley clip [16] from the cable drive pulley [1].

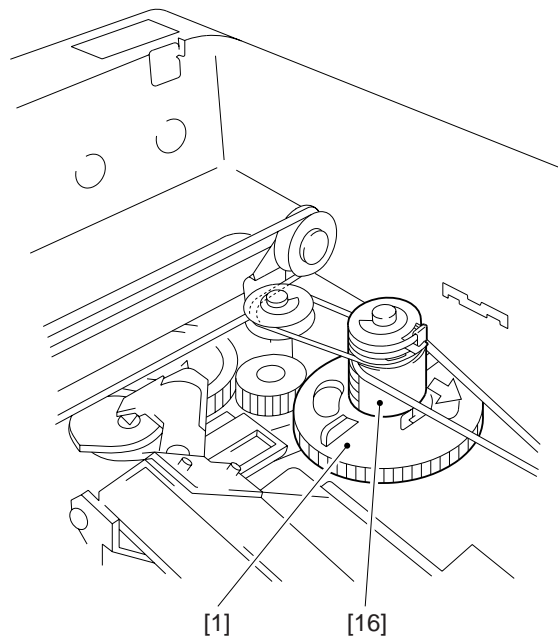

Figure 11-233

#### 4. Positioning the No. 1 Mirror Mount

- 1) Fix the rear and the front of the No. 1 mirror mount [1] temporarily to the metal fixing [2] of the forwarding cable.

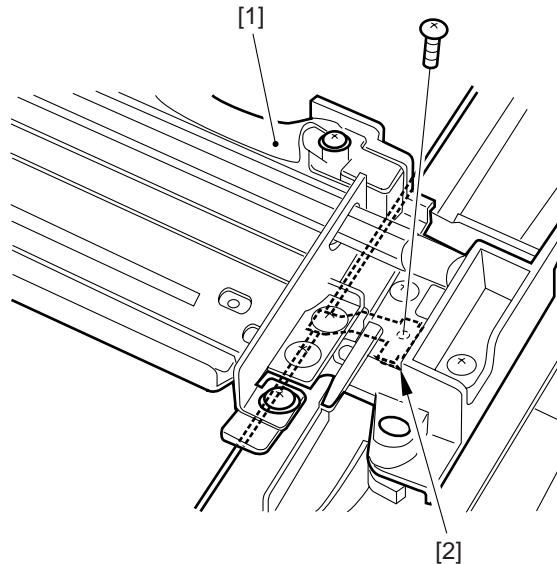

Figure 11-234 (rear)

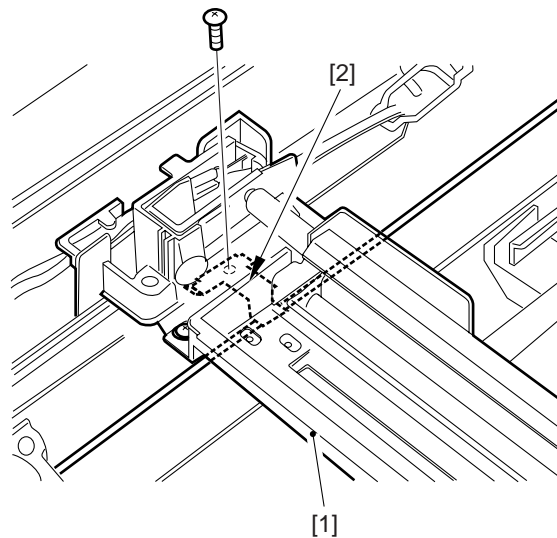

Figure 11-235 (front)

- 2) Turn the cable drive pulley [4] so that the three shafts [3] of the mirror positioning tool for rear and front is as shown.

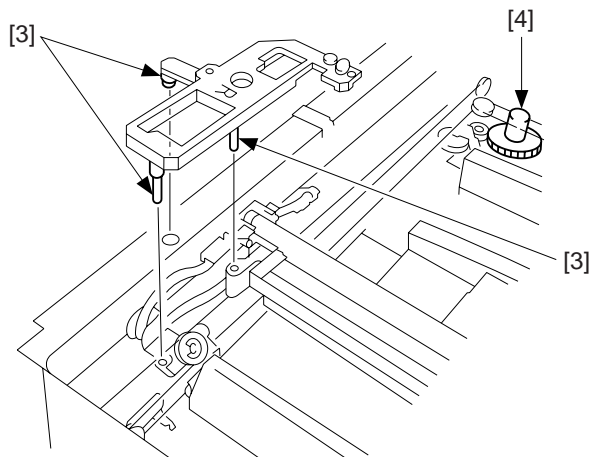

Figure 11-236 (rear)

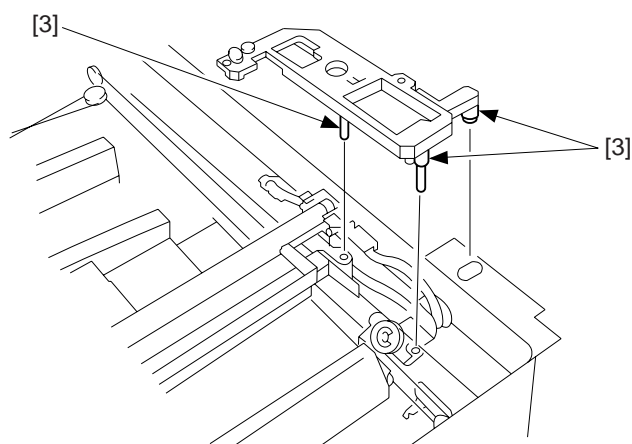
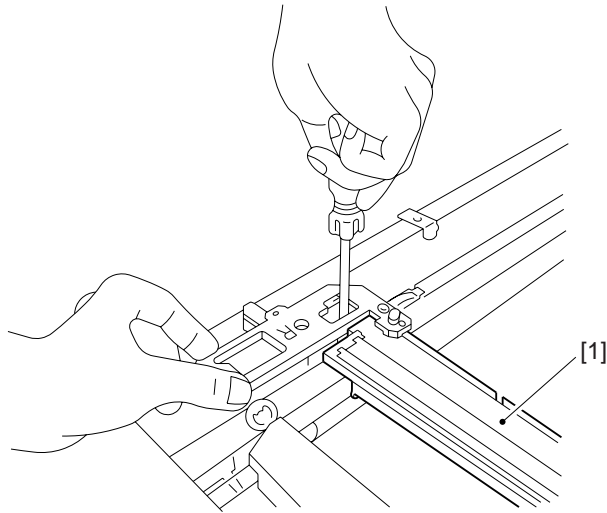

Figure 11-237(front)



- 3) While keeping the condition of step 2), tighten the positioning screw on the rear and front of the No. 1 mirror mount [1].



**Figure 11-238 (rear)**

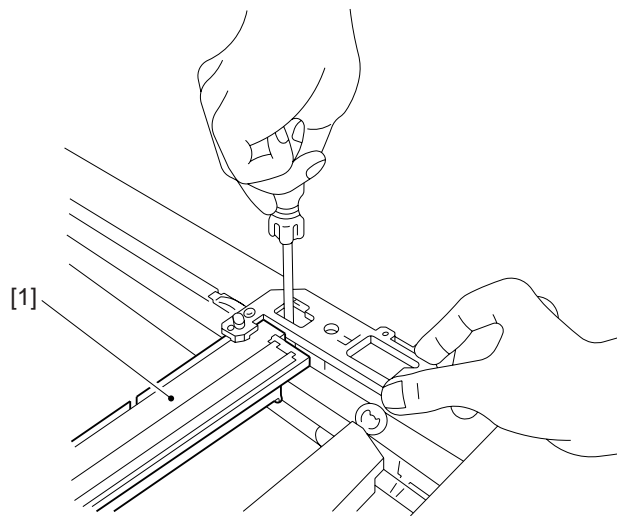

**Figure 11-239 (front)**

f. Point to Note When Mounting the Scanning Lamp

When mounting the scanning lamp, be sure that its logo mark (manufacturer's name) is toward the front. Further, be sure that the protrusion near its middle is as shown.

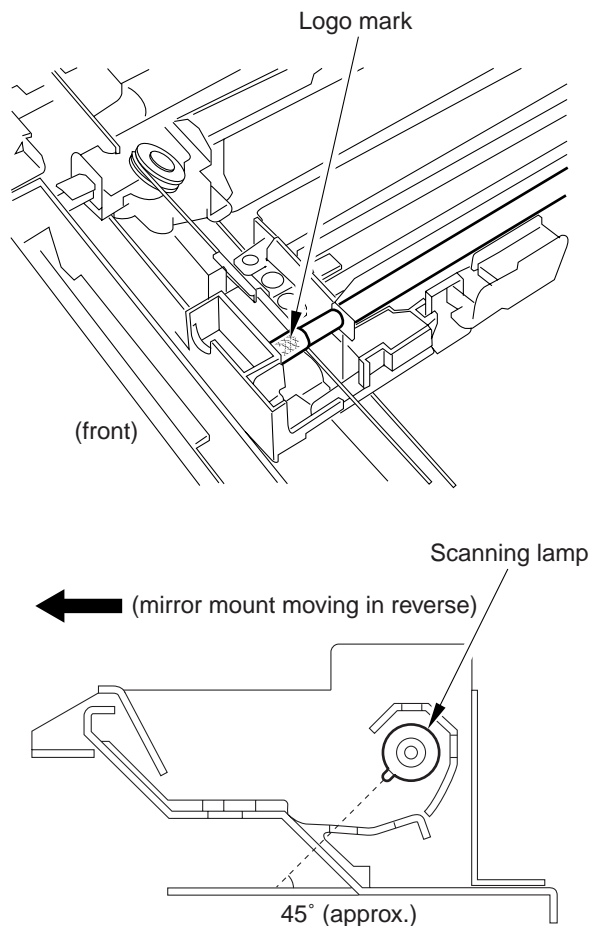

Figure 11-240

Caution:

- If you have replaced the scanning lamp, you must adjust the intensity of the lamp (p. 11-44) and perform AE adjustment.
- Do not touch the lamp when handling it.

g. Points to Note When Mounting the Fuse

When mounting the thermal fuse of the No. 1 mirror mount, be sure that the fuse is oriented as shown.

Make sure that the fuse is in contact with the reflecting plate.

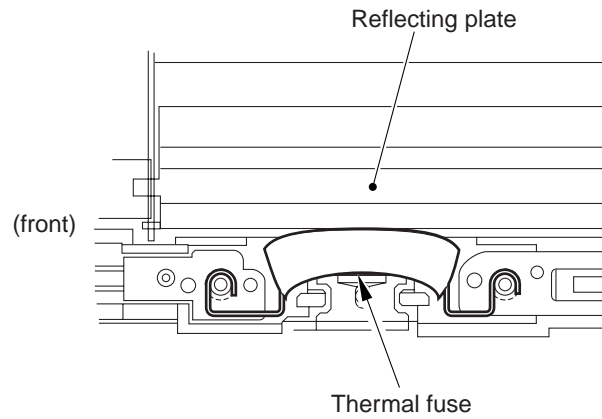

**Figure 11-241**

## B. ADF

### 1. Adjusting the Original Stop Position

Adjust the original stop position in the following order:

1. Correcting original skew
2. Adjusting the rear/front original stop position
3. Adjusting the original leading edge stop position

### 2. Correcting Original Skew

- 1) Obtain a sheet of A4 or LTR white copy paper, and draw two lines as indicated.
  - The sheet will be used as a test sheet.

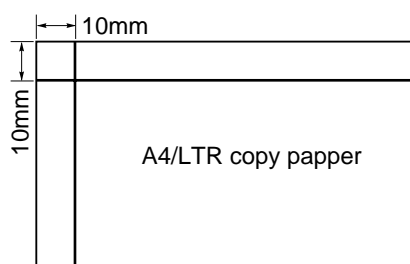

Figure 11-242

- 2) Turn on the machine, and place the test sheet prepared in step 1) on the original tray.

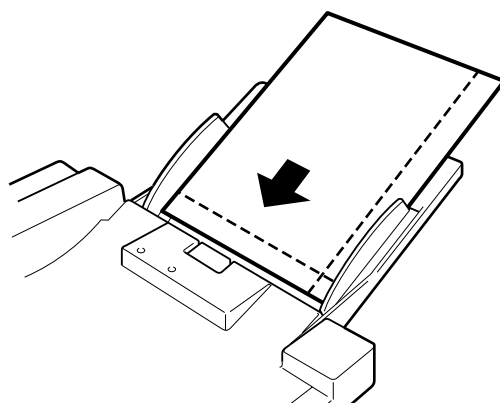
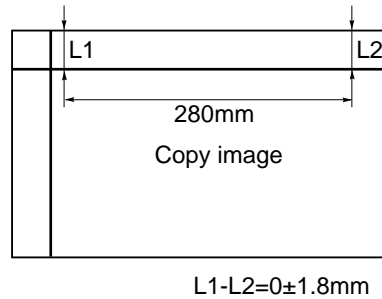

Figure 11-243

- 3) Press the Copy Start key to make a copy.
- 4) Check to make sure that the difference between L1 and L2 on the copy is 1.8 mm (standard) or less.



**Figure 11-244**

- 5) If the difference is not as specified, turn the adjusting screw found to the side of the left hinge unit to make adjustments.

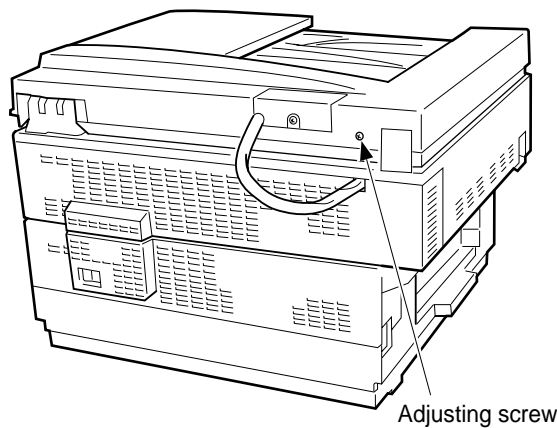

**Figure 11-245**

Relationship between Adjusting Screw and L1/L2

Direction of turn	Relationship between L1 and L2
Clockwise	$L1 > L2$
Counterclockwise	$L1 < L2$

**Table 11-203**

### 3. Adjusting the Rear/Front Original Stop Position

You must first correct original skew before adjusting the rear/front original stop position.

- 1) Obtain a sheet of A4 or LTR white copy paper, and draw two lines as indicated.
  - The sheet will be used as a test sheet.

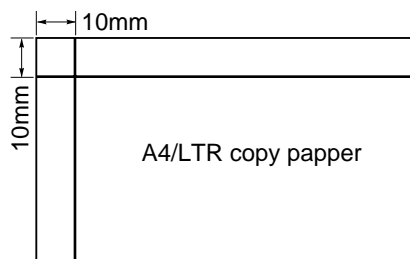

Figure 11-246

- 2) Remove the original tray cover from below the original tray.

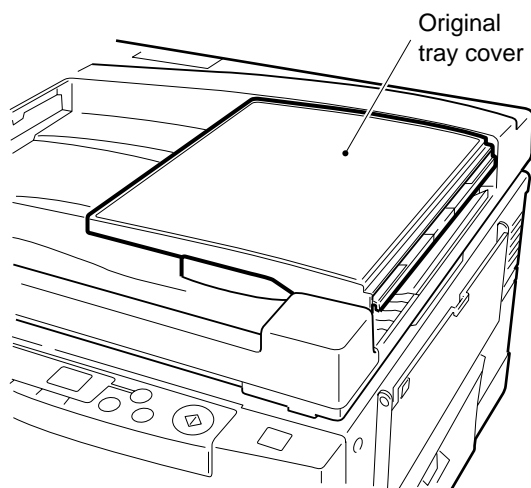
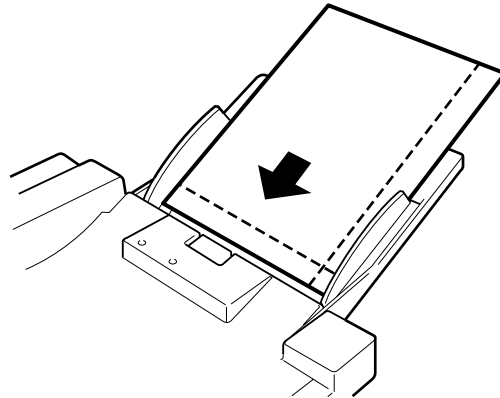

Figure 11-247

- 3) Turn on the machine, and place the test sheet prepared in step 1) on the original tray.



**Figure 11-248**

- 4) Press the Copy Start key to make a copy.  
5) Check to make sure that the distance L3 on the copy image indicated is  $10 \pm 2.5$  mm (standard) or less.

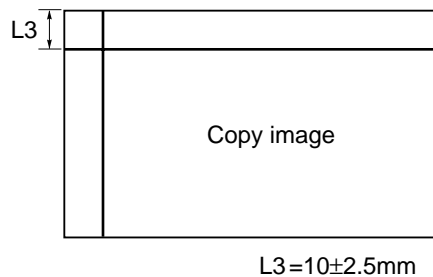

**Figure 11-249**

- 6) If the distance is not as specified, loosen the pinion gear positioning screw under the original tray, and adjust the position of the pinion gear.

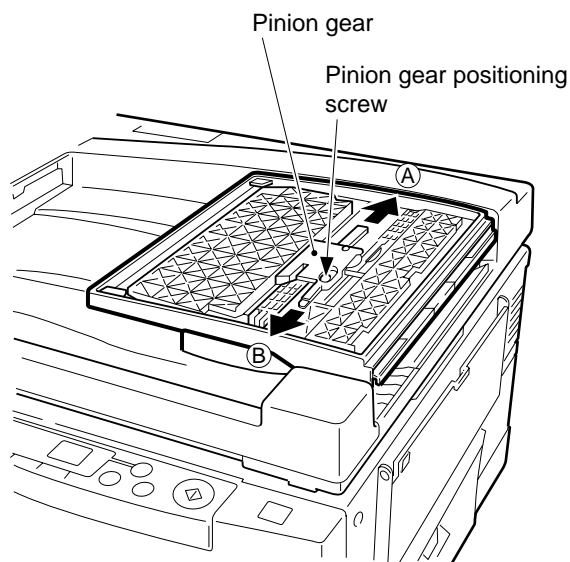

Figure 11-250

Relationship between Pinion Gear Position and L3

Direction of pinion gear	L3
A	Increases
B	Decreases

Table 11-204



#### 4. Adjusting the Original Leading Edge Stop Position

You must first correct original skew and adjust the rear/front original stop position before adjusting the original leading edge stop position.

- 1) Obtain a sheet of A4 or LTR white copy paper, and draw two lines as indicated.
  - The sheet will be used as a test sheet.

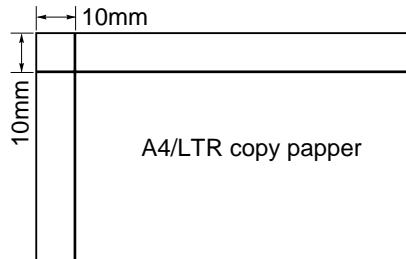

Figure 11-251

- 2) Remove the screw, and remove the ADF controller cover.

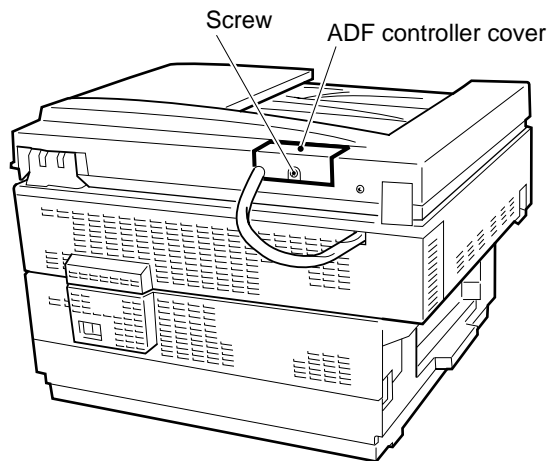

Figure 11-252

- 3) Turn on the machine, and place the test sheet prepared in step 1) on the original tray.

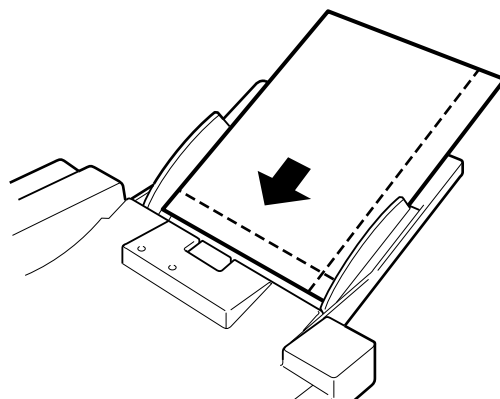

Figure 11-253

- 4) Press the Copy Start key to make a copy.  
 5) Check to make sure that the distance L4 on the copy image indicated is  $10 \pm 2.0, -2.5$  mm (standard) or less.

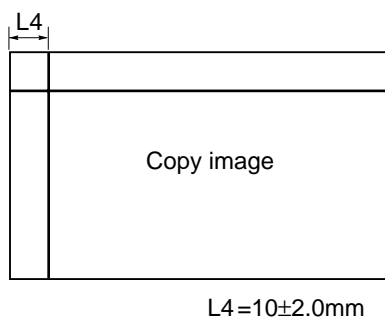

Figure 11-254

- 6) If the distance is not as specified, shift bit 1 of the DIP switch (SW1) on the ADF controller PCB to ON, and place an A4 or LTR white copy paper on the original tray.

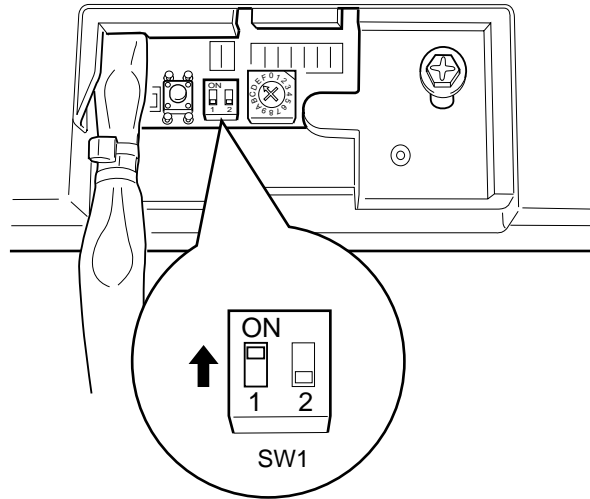

Figure 11-255

- 7) Press the push switch (PSW) on the ADF controller PCB.
- The copy paper will be picked up from the original tray and stopped on the copyboard glass.

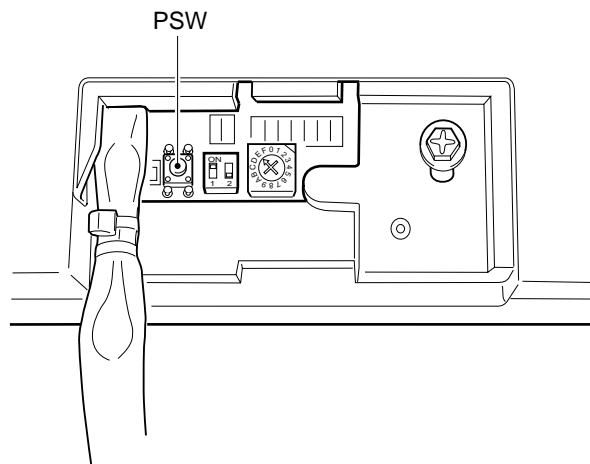

Figure 11-256

- 8) Use the rotary switch (SW2) on the ADF controller PCB to adjust the original leading edge stop position.  
 Moving the rotary switch by a single notch changes the original stop position by about 0.3 mm.  
 Press the push switch (PSW) after deciding on a position to discharge the copy paper and store the optimum value.

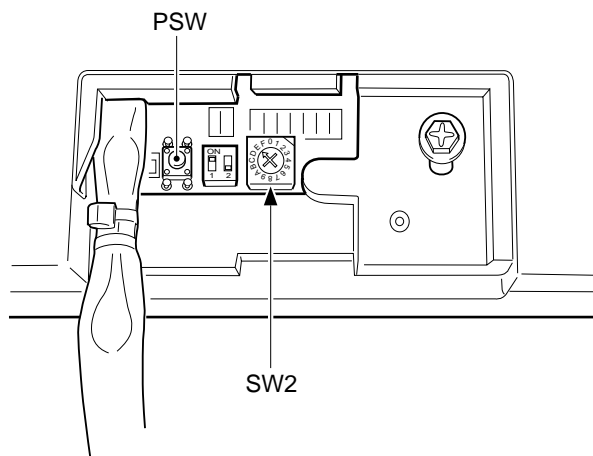

Figure 11-257

Relationship between Rotary Switch Direction and Original Position

Direction of rotary switch	Position (shift) of original
Clockwise	Toward leading edge
Counterclockwise	Toward trailing edge

Table 11-205

**Example:**

If L4 is 13 mm,

You must shift the original stop position toward the leading edge by 3 mm.

- 1) Place a sheet of A4 or LTR white copy paper on the original tray.
- 2) Shift bit 1 of the DIP switch (SW1) on the ADF controller PCB to ON; then, push the push switch (PSW) to pick up the copy paper.

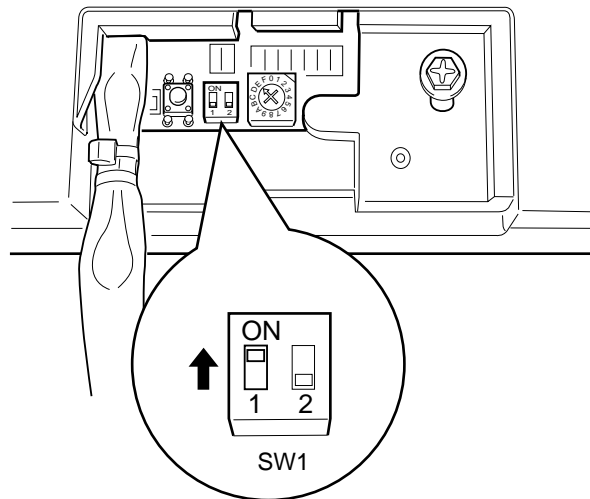

**Figure 11-258**

- 3) Turn the rotary switch (SW2) on the ADF controller PCB clockwise by 10 notches.

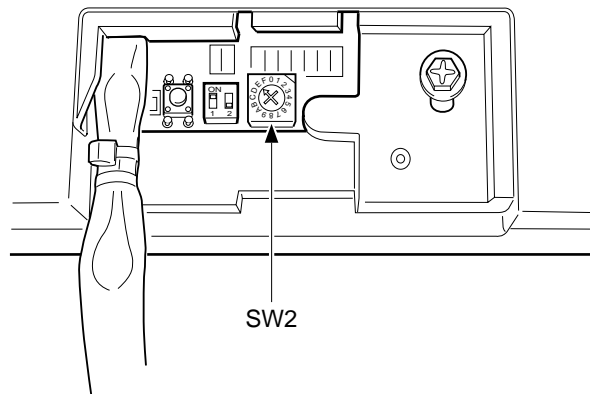

**Figure 11-259**

- 4) Press the push switch (PSW) on the ADF controller PCB.
  - The copy paper on the copyboard will be discharged, and the optimum value will be stored.

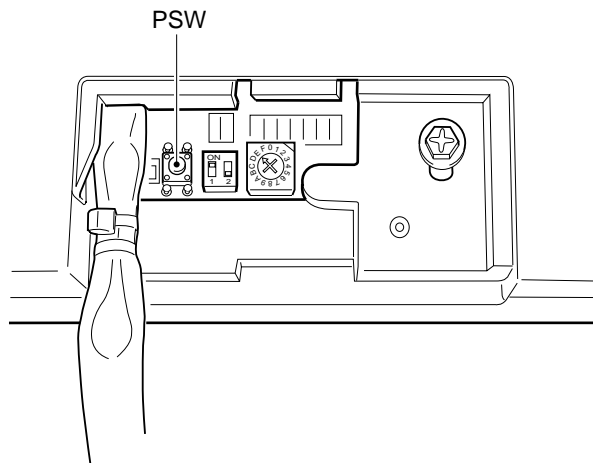

Figure 11-260

## C. Electrical

### 1. After Replacing the Major Parts

Parts	Work
Scanning lamp	<ol style="list-style-type: none"> <li>1. Scanning lamp intensity adjustment (LAMP_ADJ)</li> <li>2. AE adjustment</li> </ol>
AE sensor PCB	<ol style="list-style-type: none"> <li>1. AE adjustment</li> </ol>
Composite power supply PCB*1	<ol style="list-style-type: none"> <li>(1. Scanning lamp intensity adjustment (LAMP_ADJ))</li> <li>(2. AE adjustment)</li> <li>3. Voltage correction for APVC measurement (PW_OFST)</li> <li>4. Current correction for APVC measurement (IP_ADJ)</li> </ol>
Pre-exposure lamp	<ol style="list-style-type: none"> <li>1. Pre-exposure lamp output adjustment (PREX_LP)</li> </ol>
DC controller PCB	<ol style="list-style-type: none"> <li>1. Scanning lamp intensity adjustment (LAMP_ADJ)</li> <li>2. AE adjustment</li> <li>3. Leading edge non-image width adjustment (LE_BLANK)</li> <li>4. Image leading edge margin adjustment (REGIST)</li> <li>5. Primary charging output voltage correction (PRIMARY)</li> <li>6. APVC measurement current correction (IP_OFST)</li> <li>7. Voltage correction for measurement of APVC (PW_OFST)</li> <li>8. Current correction for measurement of APVC (IP_ADJ)</li> <li>9. Ratio fine adjustment (LENS_ADJ)</li> <li>10. Pre-exposure lamp output adjustment (PREX_LP)</li> </ol>
Drum unit	<ol style="list-style-type: none"> <li>1. Primary charging output voltage correction (PRIMARY)</li> <li>2. APVC measurement current correction (IP_OFST)</li> </ol>
ADF controller PCB	<ol style="list-style-type: none"> <li>1. Original leading edge stop position adjustment</li> </ol>

\*1: If you have replaced the composite power supply PCB, check copy images using the Test Sheet; if (and only if) an image fault is found, adjust the intensity of the scanning lamp and execute AE adjustment.

**Table 11-206**

## 2. Adjusting the Intensity of the Scanning Lamp

You must perform this adjustment whenever you have replaced any of the following:

- DC controller PCB
- Composite power supply PCB (See p. 11-41.)
- Scanning lamp

### Caution:

If you have performed this adjustment, be sure to perform AE adjustment.

### Making Adjustments

- If you have replaced the DC controller PCB or the composite power supply PCB,
  - 1) Select '38' in service mode.
    - The display will indicate '38'.
  - 2) Press the Copy Start key.
    - The existing setting will flash.
  - 3) Enter the value recorded on the service label using the +/- key.
  - 4) Press the AE key to store the new setting.
- If you have replaced the scanning lamp,
  - 1) Set the Density correction dial (VR107) to the middle.

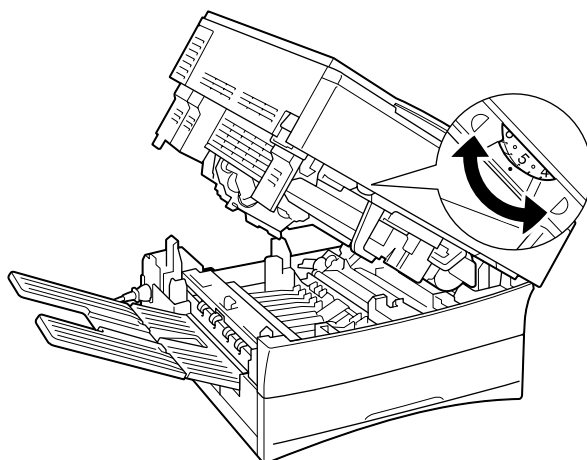

Figure 11-261

- 2) Turn off the AE mechanism, and set the Copy Density Adjustment lever on the control panel to the middle.
- 3) Place the Test Sheet on the copyboard.
- 4) Select '38' in service mode.
  - The display will indicate '38'.
- 5) Press the Copy Start key.
  - The existing setting will flash.



- 6) Change the setting using the +/- key until gray scale No. 9 is barely visible by way of adjusting the intensity of the scanning lamp.
- The setting may be between 0 and 99.
  - For each '1', the lamp supply voltage will change about 0.15 V (for 120V model) or about 0.30 V (for 220/240V model).
  - A higher setting will decrease the intensity of the lamp, thereby making copies darker.
  - A lower setting will increase the intensity of the lamp, thereby making copies lighter.

### 3. AE Adjustment

Perform this adjustment if you have replaced any of the following:

- DC controller PCB
- Composite power supply PCB (See p.11-41)
- AE sensor PCB
- Scanning lamp

#### Making Adjustments

##### Preparatory Work

- Obtain a newspaper which is more or less even in density. (Avoid ones with photos or large text characters.)
- Obtain five sheets of white sheets of paper
- Make sure that the intensity of the scanning lamp has been adjusted when you have replaced the scanning lamp.
- Set the density correction dial (VR107) to the middle setting.

- 1) Select '40' in service mode.
  - The display will indicate '40'.
- 2) Press the Copy Start key.
  - The scanner will move forward, and the scanning lamp will turn on.
- 3) Turn VR103 on the DC controller PCB fully clockwise.

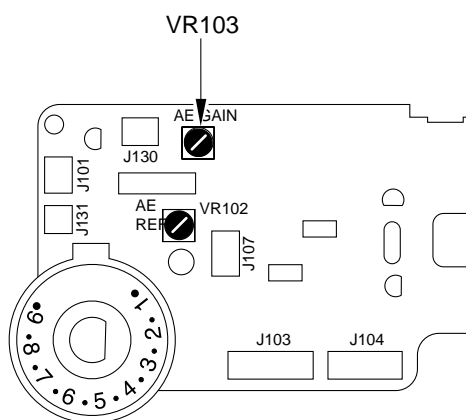

Figure 11-262

- 4) Place a newspaper on the copyboard, and close the copyboard cover.
- 5) Turn VR102 so that the reading in the display is 'A3' through 'Ad'.

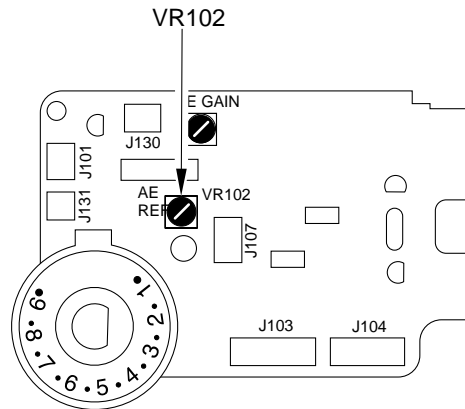

Figure 11-263

- 6) Remove the newspaper from the copyboard, and place five sheets of copy paper on the copyboard glass in its place; then, close the copyboard cover.
- 7) Turn VR103 on the DC controller PCB so that the reading on the control panel is '52' through '5c'.

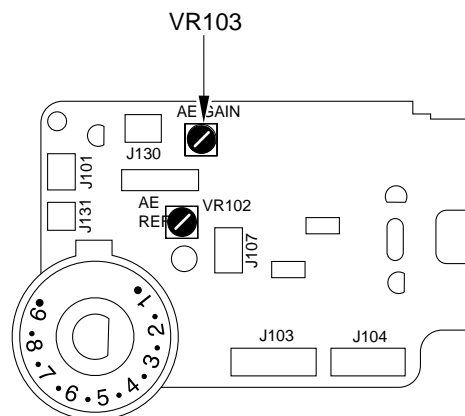

Figure 11-264

- 8) Repeat steps 4) through 7) so that the values of both VR102 and VR103 are target values.

**Caution:**

If you cannot set VR102 and VR103 to the target values at the same time, turn VR103 fully counterclockwise, and go back to step 4) and make adjustments once again.

- 9) Make a copy, and check to make sure that the density of characters is adequate.
- If the copy is foggy or its characters are too light, go back to step 1) and start over.
  - If there is no change after adjustment for a second time, use the density correction dial (VR107).

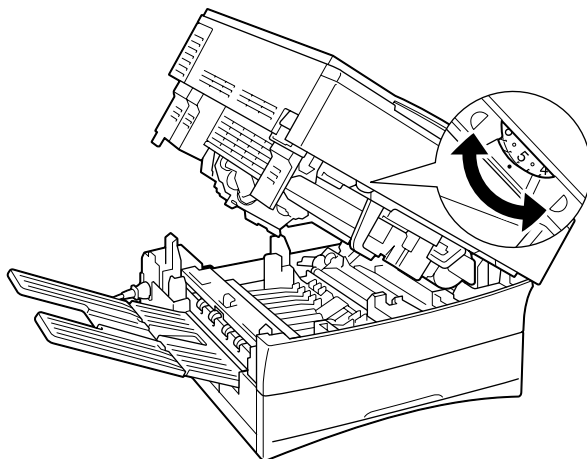

Figure 11-265

#### 4. Primary Charging Output Voltage Correction (PRIMARY)

Perform this adjustment whenever you have replaced any of the following:

- DC controller PCB
- Drum unit

Making Adjustments

- If you have replaced the DC controller PCB,

- 1) Select '32' in service mode.
    - The display will indicate '32'.
  - 2) Press the Copy Start key.
    - The existing setting will flash.
  - 3) Enter the value of 'PRIMARY' recorded on the service label using the +/- key.
  - 4) Press the AE key to store the new value.
- If you have replaced the drum unit, execute 'Installation/drum unit replacement mode' (U7) in the user mode.  
(See Chapter 9.II.A.6. "Adjusting the Machine.")

#### 5. APVC Measurement Current Correction (IP\_OFST)

Perform this adjustment whenever you have replaced any of the following:

- DC controller PCB
- Drum unit

Making Adjustments

- If you have replaced the DC controller PCB,

- 1) Select '33' in service mode.
    - The display indicate '33'.
  - 2) Press the Copy Start key.
    - The existing setting will flash.
  - 3) Enter the value of 'IP\_OFST' recorded on the service label using the +/- key.
  - 4) Press the AE key to store the new value.
- If you have replaced the drum unit, execute 'Installation/drum unit replacement mode' (U7) in the user mode.  
(See Chapter 9.II.A.6. "Adjusting the Machine.")

### 6. Voltage Correction for Measurement of APVC (PW\_OFST)

Perform this adjustment if you have replaced any of the following:

- DC controller PCB
- Composite power supply PCB

#### Making Adjustments

- 1) Select '34' in service mode.
    - The display will indicate '34'.
  - 2) Press the Copy Start key.
    - The existing setting will flash.
  - 3) Enter the value of 'PW\_OFST' recorded on the service label using the +/- key.
  - 4) Press the AE key to store the new value.
  - 5) Execute 'U7' in user mode (installation/drum replacement mode).
- If you have replaced the composite power supply PCB,
    - 1) Select '34' in service mode.
      - The display will indicate '34'.
    - 2) Press the Copy Start key.
      - The existing setting will flash.
    - 3) Enter the value of 'PW\_OFST' indicated on the new composite power supply PCB using the +/- key.

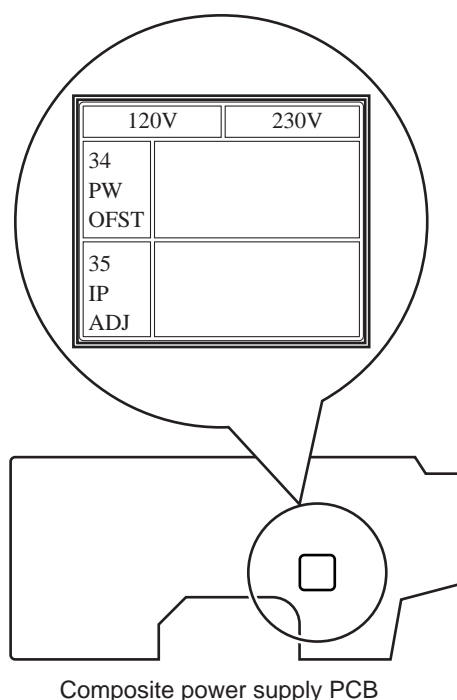

Figure 11-266

- 4) Press the AE key to store the value.
- 5) Record the new value on the service label.
- 6) Execute 'U7' in user mode (installation/drum replacement mode).

## 7. Current Correction for Measurement of APVC (IP\_ADJ)

Perform this adjustment whenever you have replaced any of the following parts:

- DC controller PCB
- Composite power supply PCB

### Making Adjustments

- If you have replaced the DC controller PCB,
  - 1) Select '35' in service mode.
    - The display will indicate '35'.
  - 2) Press the Start key.
    - The existing setting will flash.
  - 3) Enter the value of 'IP\_ADJ' recorded on the service label using the +/- key.
  - 4) Press the AE key to store the new setting.
- If you have replaced the composite power supply PCB,
  - 1) Select '35' in service mode.
    - The display will indicate '35'.
  - 2) Press the Copy Start key.
    - The existing setting will flash.
  - 3) Enter the value of 'IP\_ADJ' indicated on the new composite power supply PCB using the +/- key.

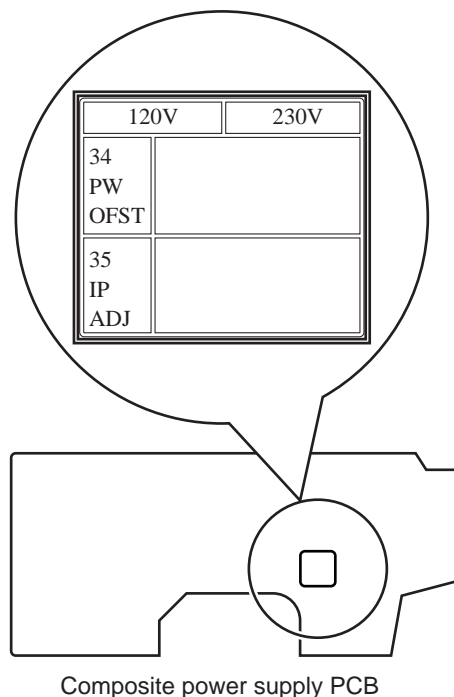

**Figure 11-267**

- 4) Enter the AE key to store the new setting.
- 5) Record the new value on the service label.

## 8. Ratio Fine Adjustment (LENS\_ADJ)

Perform this adjustment whenever you have replaced the following:

- DC controller PCB

Making Adjustments

- When you have adjusted the DC controller PCB,
  - 1) Select '36' in service mode.
    - The display will indicate '36'.
  - 2) Press the Copy Start key.
    - The existing setting will flash.
  - 3) Enter the value of 'LENS\_ADJ' indicated on the service label using the +/- key.
  - 4) Press the AE key to store the new value.

## 9. Pre-Exposure Lamp Output Adjustment (PREX\_LP)

Perform this adjustment whenever you have replaced any of the following:

- DC controller PCB
- Pre-exposure lamp

Making Adjustments

- If you have replaced the DC controller PCB,
  - 1) Select '37' in service mode.
    - The display will indicate '37'.
  - 2) Press the Copy Start key.
    - The existing setting will flash.
  - 3) Enter the value of 'PREX\_LP' recorded on the service label using the +/- key.
  - 4) Press the AE key to store the new value.
  - 5) Execute 'U7' in user mode (installation/drum replacement mode).
- If you have replaced the pre-exposure lamp,
  - 1) Select '37' in service mode.
    - The display will indicate '37'.
  - 2) Press the Copy Start key.
    - The existing setting will flash.
  - 3) Enter the value of 'PREX\_LP' recorded on the label attached to the new pre-exposure lamp using the +/- key.
  - 4) Press the AE key to store the new value.
  - 5) Execute 'U7' in user mode (installation/drum replacement mode).



**10. Checking the Photointerrupters**

- 1) Set the meter range to 12 VDC.
- 2) Connect the - probe [1] of the meter to the grounding terminal [2].

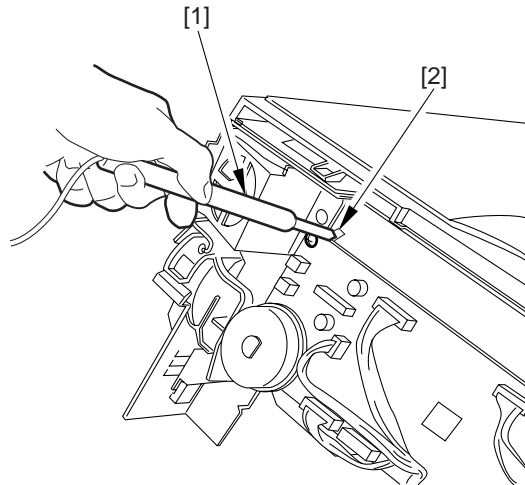

**Figure 11-268**

- 3) Make checks as instructed.

**Reference:**

The photointerrupters other than those shown in Table 11-209 are connected in a matrix, hence the omission from the table.

Sensor	Connector	Checks		Voltage (approx.)
PS1 Scanner home position sensor (SCHP)	J101-3	During standby, move the scanner by hand.	When the light-blocking plate is at PS1, When the light-blocking plate is not at PS1,	5V 0V
PS2 Lens home position sensor (LHP)	J109-10	During standby, move the lens mount by hand.	When the light-blocking plate is at PS2, When the light-blocking plate is not at PS2,	5V 0V
PS4 Vertical path roller paper sensor (PDP)	J132-5	During standby, move the detecting lever by hand.	When the light-blocking plate is at PS4, When the light-blocking plate is not at PS4,	5V 0V
Q751 Pre-registration roller paper sensor (RPD)	J108-1	During standby, move the detecting lever by hand.	When the light-blocking plate is at Q751, When the light-blocking plate is not at Q751,	0V 5V

**Table 11-209**

## III. TROUBLESHOOTING IMAGE FAULTS

### A. Making Initial Checks

#### 1. Site Environment

Check the site against the following considerations:

- a. The voltage of the power source is as rated.
- b. The site must not be subject to high temperature or humidity (as near a water faucet, water boiler, humidifier) or dust. The machine must not be near a source of fire.
- c. The site must not be subject to ammonium gas.
- d. The machine must not be exposed to direct rays of the sun. (As necessary, instruct the user to provide curtains.)
- e. The site must be well ventilated.
- f. The machine must be kept level.

#### 2. Checking the Originals

Check the originals to find out whether the problem in question is caused by the machine or the originals.

- a. The copy density adjusting lever is often best if set to the middle index.
- b. Originals with a red tint tend to produce copies with poor contrast; e.g., red sheets.
- c. Originals which are diazo copies or with transparency tend to produce copies which can be mistaken for "foggy" copies.

Originals prepared in pencil tend to produce copies with "light" images.

#### 3. Copyboard Cover and Copyboard Glass

If the copyboard cover or the copyboard glass is soiled, clean it with mild detergent solution or alcohol; if scratched, replace it.

#### 4. Lens

Check the lens for dirt. If any, clean it with a cotton swab.

#### 5. Checking the Transfer Charging Roller

- a. Check the transfer charging roller for dirt or fault (scratches).

#### 6. Feeding Assembly

Check the feeding assembly for dirt. If any dirt is found, clean it with a moist cloth.

#### 7. Copy Paper

- a. Is copy paper of a type recommended by Canon?
- b. Is copy paper moist?  
Try paper fresh out of package.

## 8. Others

When a machine is brought in from a cold place (e.g., warehouse) to a warm place, condensation can occur inside it, leading to various problems; e.g.,

- a. Condensation on the scanner (glass, lens, mirror, reflecting plate) will cause dark images.
- b. The drum is likely to be cold (high OPC electrical resistance), not enabling good contrast.
- c. Condensation in the pickup/feeding assembly tends to cause feeding faults.
- d. Condensation on the lower roller of the manual feed assembly will reduce friction, causing pickup faults.

If condensation is noted, dry wipe the parts in question.

The cartridge can develop condensation if it is opened immediately after it has been brought from a cold to warm place. Instruct the user so that the cartridge is not opened before it has become used to the room temperature (one to two hours).





## B. Sample Image Faults

**NOTE:** The samples are created intentionally. The NA-3 Test Sheet was copied in the direct mode in A3 and printed with a reduction of about 19%; actual images may be somewhat different.

1. The copy is too light (halftone only).



2. The copy is too light (both halftone and solid black).

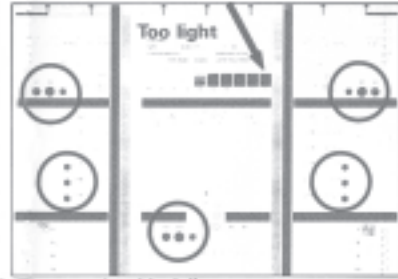

3. The copy is too light (entire copy, appreciably).

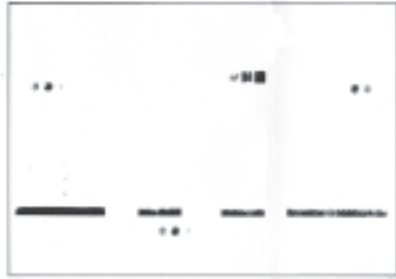

4. The copy has uneven density (darker along front).

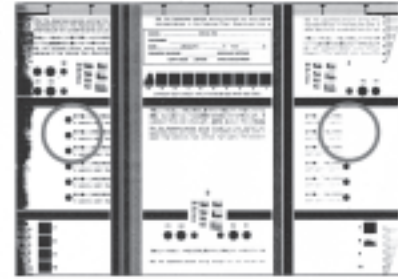

5. The copy has uneven density (lighter along front).

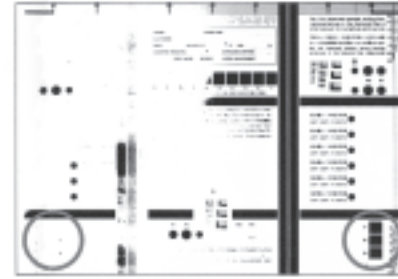

6. The copy is foggy (entire copy).

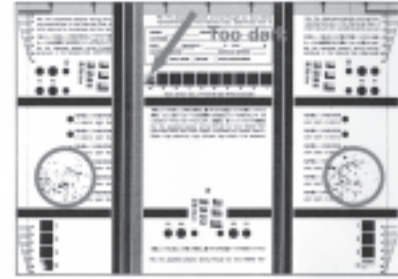

7. The copy is foggy (feeding direction).



8. The copy has black lines (feeding direction, fuzzy, thick).



9. The copy has black lines (feeding direction, fine).



10. The copy has white strips (feeding direction).†

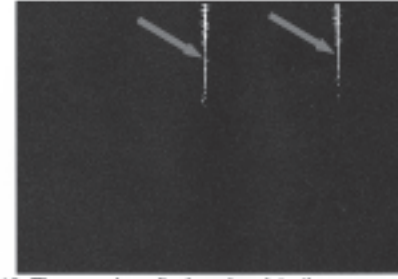

11. The copy has white lines (feeding direction).\*

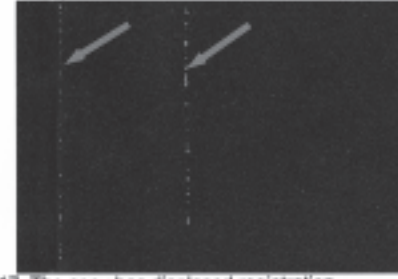

12. The copy has white strips (cross-feeding direction).



13. The back of the copy is soiled.

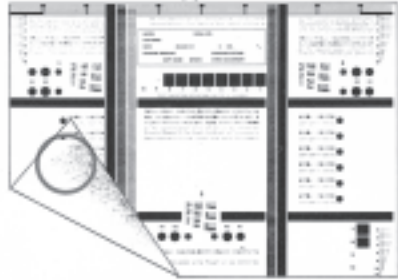

14. The copy has poor fixing.



15. The copy has displaced registration (leading edge, extremely excessive margin).



16. The copy has displaced registration (leading edge, excessive margin).



17. The copy has displaced registration (leading edge, no margin).



18. The copy has blurred images.



19. The copy is foggy (cross-feeding direction).



20. The copy has poor sharpness.



21. The copy is blank.



22. The copy is solid black.



\* Copies made with the copyboard lifted; faults may also appear on normally made copies.

† Strips may vary in width.

### C. Troubleshooting Image Faults

- |   |  |
|---|--|
| 1 | <b>The copy is too light. (halftone area only)</b>       |
| 2 | <b>The copy is too light. (including solid area)</b>     |
| 3 | <b>The copy is too light. (enter image, appreciably)</b> |

Cause	Step	Checks	YES/NO	Action
Lens, Reflecting plate, AE sensor, Static eliminator	1	Clean the lens, reflecting plate, AE sensor, and static eliminator. Is the problem corrected?	YES	End.
-----	2	Turn off the power in the middle of a copying run, and open the machine's top unit. Is the toner image before transfer more or less normal? (Be sure to make a check in a short time to protect the drum from light.)	NO	Go to step 6.
Transfer charging roller	3	Is the transfer charging roller normal?	NO	1. Mount the transfer charging roller correctly. 2. Replace the transfer charging roller.
Copy paper	4	Try fresh copy paper. Is the problem corrected?	YES	1. The copy paper may be moist. Instruct the user on the correct method of storage. 2. Inform the user that using non-recommended paper may not bring the best results.
Transfer lower guide, Varistor	5	Measure the electrical resistance on the transfer lower guide plate and the side plate (metal) of the fixing assembly. Is it 0Ω?	YES	1. Check to find out if the transfer lower guide happens to be in contact with a metal part (side plate). 2. Replace the varistor.
Composite power supply PCB, DC controller PCB			NO	1. Check the transfer high-voltage terminal contacts for electrical continuity. 2. Check the composite power supply and the DC controller PCB.
Drum unit	6	Replace the drum unit. Is the problem corrected?	YES	End.
Developing bias, Developing bias terminal			NO	Replace the electric unit (composite power supply PCB, DC controller PCB).



- 4 The copy has uneven density. (darker at front)
- 5 The copy has uneven density. (lighter at front)

Cause	Step	Checks	YES/NO	Action
Scanner	1	Clean the scanning lamp, reflecting plate, lens, and mirror. Is the problem corrected?	YES	End.
Toner cartridge Scanning lamp	2	Turn off the power in the middle of a copying run, and open the machine. Is the toner image on the photosensitive drum before transfer more or less uneven?	YES	1. Replace the toner cartridge. 2. Replace the scanning lamp.
Transfer charging roller			NO	1. Mount the transfer charging roller correctly. 2. Replace the transfer charging roller correctly.

6 The copy is foggy. (entire face)

Cause	Step	Checks	YES/NO	Action
-----	1	Is the density correction dial (VR107) or the density adjusting lever set to the middle setting?	NO	Set the dial or the lever to the middle setting, and make a copy. If the image is still foggy, to step 2).
Scanner	2	Clean the scanning lamp, reflecting plate, lens, and mirror. Is the problem corrected?	YES	End.
Grounding spring	3	Set the drum unit in the machine. Is there electrical continuity between the PCB of the base of the drum and the machine's top unit?	NO	Check to see if the grounding spring is mounted correctly (in reference to the drum drive gear).
Scanning lamp, Developing bias			YES	1. Check the activation of the scanning lamp. 2. Check the developing assembly.



- 7 The copy is foggy vertically.**
- 8 The copy has black lines. (vertical, fuzzy, thick)**
- 9 The copy has black lines. (vertical, fine)**

Cause	Step	Checks	YES/NO	Action
Scanner	1	Clean the scanning lamp, reflecting plate, lens, and mirror. Is the problem corrected?	YES	End.
Transfer guide assembly	2	Clean the transfer guide assembly. Is the problem corrected?	YES	End.
Drum unit	3	Take out and then set the drum unit once again. Is the problem corrected?	YES	End.
			NO	Replace the drum unit.

- 10 The copy has white spots. (vertical)**
- 11 The copy has white lines. (vertical)**

Cause	Step	Checks	YES/NO	Action
Fixing assembly	1	Turn off the power in the middle of a copying run, and open the machine's top unit. Does the copy image before moving through the fixing assembly have white spots or white lines?	YES	Check the fixing assembly.
Toner cartridge	2	Turn off then on the machine. Is the problem corrected?	YES	Advise the user that the toner cartridge is running out of the toner.
Static eliminator	3	Clean the static eliminator. Is the problem corrected?	YES	End.
Transfer charging roller	4	Is there foreign matter or scratches in the transfer charging roller assembly?	YES	Remove the foreign matter, or replace the transfer charging roller.
Drum unit			NO	Replace the drum unit.

**12 The copy has white spots. (horizontal)**

Cause	Step	Checks	YES/NO	Action
Copy paper	1	Is the paper of a recommended type?	YES	Try a recommend type. If the results are good, ask the user to use a recommended type.
	2	Try paper fresh out of package. Is the problem corrected?	YES	The paper may be moist. Instruct the user on the correct method of storing paper.
Scanner rail	3	Is the problem noted at the same position on all copies?	YES	1. Check the scanner rail for foreign matter. 2. Adjust the tension of the scanner cable.
Scanning lamp, Developing bias			NO	Check the scanning lamp for flickering and the presence/absence of a developing bias.

**13 The back of the copy is soiled.**

Cause	Step	Checks	YES/NO	Action
-----	1	Turn off the power while copy paper is moving through the feeding assembly. Is the back of the paper soiled?	NO	Go to step 3.
Transfer guide assembly	2	Is the transfer guide assembly soiled?	YES	1. Clean the transfer guide. 2. Clean the registration roller. 3. Check the varistor. 4. Check the developing assembly for leakage of toner.
Feeding assembly	3	Is the feeding assembly soiled?	YES	Clean the feeding assembly.
Pickup guide assembly, Delivery roller			NO	Clean the pickup guide assembly and the delivery roller.

**14 The copy has a fixing fault.**

Cause	Step	Checks	YES/NO	Action
Copy paper	1	Is the copy paper of a recommended type?	NO	Try a recommended type. If the results are good, ask the user to use a recommended type.
Fixing film	2	Is the problem vertical and, in addition, in the form of lines?	YES	Check the fixing film and the fixing lower roller for scratches. If there are scratches, replace them.
Fixing heater	3	Does the heater turn on when the Copy Start key is pressed?	NO	See "The fixing heater fails to turn on."
DC controller PCB, Composite power supply PCB			YES	The control temperature of the fixing heater is likely to be too low. Check the fixing assembly top unit, DC controller PCB, and composite power supply PCB.

- 15 The copy has a misplaced leading edge. (extremely excess margin)**
- 16 The copy has a misplaced leading edge. (excess margin)**
- 17 The copy has a misplaced leading edge (no margin)**

Cause	Step	Checks	YES/NO	Action
Pickup roller, Pickup clutch, Cassette	1	Make copies using the cassette and manually. Are the results the same?	NO	Check the pickup roller, pickup clutch, and cassette. Or, replace them.
Sensor (PS1), Light-blocking plate	2	Are the scanner home position sensor (PS1) and the light-blocking plate normal? (See the instructions on how to check the photointerrupter.)	NO	Replace the sensor, or check the light-blocking plate.
Image leading edge margin	3	Execute image leading edge margin adjustment. Is the problem corrected?	YES	End.
Solenoid (SL2), DC controller PCB	4	Does the registration clutch solenoid (SL2) operate normally?	NO	1. Check the solenoid (SL2). 2. Check the DC control PCB.
Copy paper	5	Is the paper of a recommended type?	NO	Try a recommended type. If the results are good, ask the user to use a recommended type.
Registration clutch			YES	Check the registration clutch.

**18 The copy has a blurred image.**

Cause	Step	Checks	YES/NO	Action
Scanner drive cable	1	Does the cable wind on itself when the scanner is moving? Or, is the cable too slack or too taut?	YES	1. Route the cable correctly. 2. If the cable is twisted or frayed, replace it.
Scanner rail	2	Move the No. 1 mirror mount slowly by hand. Does it move slowly?	YES	Clean the surface of the scanner rail with alcohol. Then, apply lubricant. (CK-0551)
-----	3	Is abnormal noise heard from the scanner motor?	YES	See "The scanner fails to move forward/in reverse."
Feeding system	4	Does the copy paper spring up or stop around the transfer assembly?	YES	Check the feeding assembly for burrs.
Drum unit			NO	Replace the drum unit.

**19 The copy has horizontal fogging.**

Cause	Step	Checks	YES/NO	Action
Scanning lamp	1	Does the scanning lamp flicker?	YES	Replace the scanning lamp.
Drum unit, High-voltage transformer assembly	2	Replace the drum unit. Is the problem corrected?	YES	End.
			NO	Check the high-voltage transformer (composite power supply PCB).
Scanning system	3	Make a reduced copy, and compare it against one made in Direct. Is the problem found at different positions?	YES	Check the scanning system.
Feeding system			NO	Check the feeding system.

**20 The copy has poor sharpness. (out-of-focus)**

Cause	Step	Checks	YES/NO	Action
-----	1	Is the image also too light?	YES	Correct the light image problem first.
Original	2	Is the original off the copyboard glass?	YES	1. Check the copyboard cover too see if it happens to be warping. 2. Instruct the user on the correct method of placing originals.
Lens	3	Turn off and then on the power switch. Does the lens move smoothly?	NO	Check the lens rail for foreign matter, and clean it.
Mirror position	4	Is the horizontal ratio in Direct within specification?	NO	Adjust the distance between No. 1 mirror and the No. 2 mirror.
Scanner	5	Clean the scanning lamp, reflecting plate, mirror, and lens. Is the problem corrected?	YES	End.
Drum unit			NO	Replace the drum unit.

**21 The copy is blank.**

Cause	Step	Checks	YES/NO	Action
Toner cartridge	1	Is toner inside the toner cartridge?	YES	Replace the toner cartridge.
	2	Has the open seal been removed?	NO	Remove the opening seal.
Drum drive assembly	3	Does the drum drive gear rotate normally?	NO	Check the drum drive assembly.  <b>Caution:</b> Be sure to install the drum unit before making checks.
High-voltage transformer	4	Is the primary charging terminal on the front left of the drum unit in firm contact with the high-voltage terminal at the machine's bottom?	YES	Check the high-voltage transformer (composite power supply PCB).
Primary high-voltage charging terminal, Drum unit			NO	1. Check the contacts for electrical continuity. 2. Replace the drum unit.

**22 The copy is solid black.**

Cause	Step	Checks	YES/NO	Action
-----	1	Does the scanning lamp remain on during copying?	NO	See "The scanning lamp fails to turn on."
			YES	Is the drum unit set correctly?

## IV. TROUBLESHOOTING MALFUNCTIONS

### A. Troubleshooting Malfunctions

#### 1 E000

Cause	Step	Checks	YES/NO	Action
Thermistor (TH1)	1	Are the connection of J102 on the DC controller PCB and the wiring to the thermistor (TH1) normal?	NO	Correct the connection of J102 on the DC controller PCB and the wiring to the thermistor (TH1).
Heater, Fuse (FU2)	2	Is there electrical continuity between J207-1 and -2 on the fixing heater side?	NO	Check the wiring from the composite power supply PCB to the fixing heater; if normal, replace the fixing assembly upper unit.
Thermistor (TH1)	3	Replace the fixing upper unit. Is the problem corrected?	YES	End.
Composite power supply PCB	4	Replace the composite power supply PCB. Is the problem corrected?	YES	End.
DC controller PCB			NO	Replace the DC controller PCB.

#### 2 E001

Cause	Step	Checks	YES/NO	Action
Thermistor (TH1)	1	Are the connection of J102 on the DC controller PCB and the wiring to the thermistor (TH1) normal?	NO	Correct the connection of J102 on the DC controller PCB and the wiring to the thermistor (TH1).
Thermistor	2	Replace the fixing assembly upper unit. Is the problem corrected?	YES	End.
Composite power supply PCB	3	Replace the composite power supply PCB. Is the problem corrected?	YES	End.
DC controller PCB			NO	Replace the DC controller PCB.

**3 E002, E003**

Cause	Step	Checks	YES/NO	Action
Thermistor (TH1)	1	Is the connection of J102 on the DC controller PCB and the wiring to the thermistor (TH1) normal?	NO	Correct the connection of J102 on the DC controller PCB and the wiring to the thermistor (TH1).
Heater, Fuse (FU2)	2	Is there electrical continuity between J207-1 and -2 on the fixing heater side?	NO	Check the wiring from the composite power supply PCB to the fixing heater; if normal, replace the fixing upper unit.
Thermistor (TH1)	3	Replace the fixing assembly upper unit. Is the problem corrected?	YES	End.
Composite power supply PCB	4	Replace the composite power supply PCB. Is the problem corrected?	YES	End.
DC controller PCB			NO	Replace the DC controller PCB.

**4 E010**

Cause	Step	Checks	YES/NO	Action
Wiring 1	1	Are the connection of J205 on the composite power supply PCB and the wiring to the main motor (M1) normal?	NO	Correct the connection of J205 on the composite power supply PCB and the wiring to the main motor (M1).
Wiring 2	2	Is the wiring from J203 and J202 on the composite power supply PCB to J103 and J105, respectively, on the DC controller PCB normal?	NO	Correct the connection and wiring of the connectors.
DC power supply	3	Turn on the power switch. Is the voltage between J901-1 (+) and -2 (-) on the main motor drive PCB about 24 V?	NO	Check the wiring from the main motor driver PCB to the composite power supply PCB; if normal, see "DC power fails to turn on."
Main motor (M1)	4	Replace the main motor (M1). Is the problem corrected?	YES	End.
DC controller PCB			NO	Replace the DC controller PCB.



**5 E030**

Cause	Step	Checks	YES/NO	Action
Wiring	1	Is the wiring from the total counter to the connector J119 on the DC controller PCB normal?	NO	Correct the wiring.
Total copy counter	2	Replace the total copy counter. Is the problem corrected?	YES	End.
DC controller PCB			NO	Replace the DC controller PCB.

**6 E064**

Cause	Step	Checks	YES/NO	Action
Wiring	1	Turn off and then on the power switch; then, set the copy count to '1'. Is 'E064' indicated at the end of a copying run?	YES	Check the wiring between the DC controller PCB and the composite power supply PCB. Check the wiring between the composite power supply PCB and the high-voltage contact PCB.
High-voltage contact	2	Is the connection between the high-voltage contacts of the machine's top and bottom units normal?	NO	Correct the high-voltage contacts of the machine's top and bottom units.
Transfer charging roller	3	Is the transfer charging roller or the contact faulty?	YES	Replace the transfer charging roller.
Primary charging roller	4	Replace the drum unit. Is the problem corrected?	YES	End.
High-voltage cable	5	Does the high-voltage cable have scratches or tears?	YES	Replace the high-voltage cable.
Composite power supply PCB	6	Replace the composite power supply PCB. Is the problem corrected?	YES	End.
DC controller PCB			NO	Replace the DC controller PCB.

**7 The keys on the control panel are locked. ('E202')**

Cause	Step	Checks	YES/NO	Action
-----	1	Is the scanner in the home position when 'E202' turns on?	NO	See "The scanner fails to move forward."
Scanner home position sensor (PS1)	2	Is the scanner home position sensor (PS1) normal? (For instructions on how to check photointerrupters, see p. 11-51.)	NO	Check the wiring from J101 on the DC controller PCB to PS1; if normal, replace PS1.
DC controller PCB			YES	Replace the DC controller PCB.

**8 E210**

Cause	Step	Checks	YES/NO	Action
-----	1	Does the lens move when the power is turned on?	NO	See "The lens fails to move."
Lens home position sensor (PS2)	2	Is the lens home position sensor (PS2) normal? (For instructions on how to check the photointerrupters, see p. 11-51.)	NO	Check the wiring from J109 on the DC controller PCB to PS2; if normal, replace PS2.
DC controller PCB			YES	Replace the DC controller PCB.

**9 E220**

Cause	Step	Checks	YES/NO	Action
-----	1	Does the scanning lamp turn on when the Copy Start key is pressed?	NO	See "The scanning lamp fails to turn on."
Composite power supply PCB	2	Replace the composite power supply PCB. Is the problem corrected?	YES	End.
DC controller PCB			NO	Replace the DC controller PCB.

**10 E240**

Cause	Step	Checks	YES/NO	Action
Wiring	1	Is the wiring from J203 and J204 on the composite power supply PCB and J103 and J104, respectively, on the DC controller PCB normal?	NO	Correct the connection and the wiring of the connectors.
Composite power supply PCB	2	Replace the composite power supply PCB. Is the problem corrected?	YES	End.
DC controller PCB			NO	Replace the DC controller PCB.

**11 E261**

Cause	Step	Checks	YES/NO	Action
Power supply frequency	1	Turn off and then on the power switch. Is the problem corrected?	YES	End. However, if 'E261' occurs frequently, advise the user to use a frequency stabilizer.
Composite power supply PCB			NO	Replace the composite power supply PCB.

**12 E400**

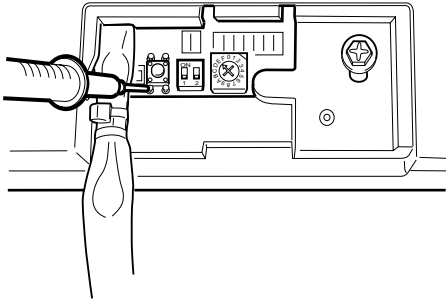
Cause	Step	Checks	YES/NO	Action
-----	1	Turn off and then on the power. Is the problem corrected?	YES	End. (Check the wiring between the copier's DC controller PCB and the ADF controller PCB.)
5V power supply	2	Set the meter to the 20VDC range, and connect the + probe to the foot of the push switch on the ADF controller PCB and the - probe to the copier ground. Is the voltage about 5V?  	NO	Replace the ADF controller PCB.
ADF controller PCB	3	Replace the ADF controller PCB. Is the problem corrected?	YES	End.
			NO	Replace the copier's DC controller PCB.

**Figure 11-401**

**13 E803**

Cause	Step	Checks	YES/NO	Action
Malfunction	1	Turn off and then on the power switch. Is the problem corrected?	YES	End.
DC controller PCB.	2	Replace the DC controller PCB. Is the problem corrected?	YES	End.
Composite power supply PCB			NO	Replace the composite power supply PCB.

**14 AC power fails to turn on.**

Cause	Step	Checks	YES/NO	Action
Power plug	1	Is the power plug connected to the power outlet?	NO	Connect the power plug.
Machine top unit	2	Is the machine's top unit closed firmly?	NO	Close the machine's top unit.
Power supply	3	Is the rated voltage present at the power outlet?	NO	Inform the user that the problem is not the machine's.
Fuse (FU501)	4	Is the fuse (FU501) on the noise filter PCB blown? (120V model: 250 V, 15 A) (220/240V model: 250 V, 6.3 A)	YES	Remove the cause, and replace the fuse.
Fuse (FU102)	5	Is the fuse (FU102) on the composite power supply PCB blown? (120V model: 125 V, 5 A) (220/240V model: 250 V, 2.5 A)	YES	Remove the cause of the problem, and replace the fuse.
Door switch (DS1)	6	Remove the door switch (DS1), and connect the meter probes to F1 and F3 or F2 and F4 of the faston of the door switch. Is the resistance about 0 Ω when the actuator is pressed add about ∞ Ω when it is released?	NO	Replace the door switch (DS1).
Noise filter PCB	7	Is the rated voltage present between J501-1 and -2?	NO	Replace the noise filter PCB.
Harness	8	Is the rated voltage present between J201-1 and J201-2?	NO	Check the connectors and the wiring if they are normal.
Connector connection 1	9	Is there electrical continuity between J111-15 on the DC controller PCB and J301-15 on the control panel PCB?	NO	Correct the electrical continuity of J111 on the DC controller PCB and J301 on the control panel PCB.
Connector connection 2	10	Is there electrical continuity between J204-1 on the composite power supply PCB and J104-7 on the DC controller PCB?	NO	Check the connection of J104 on the DC controller PCB and J204 on the composite power supply PCB; if normal, replace the DC controller PCB.
Control panel PCB	11	Replace the control panel PCB. Is the problem corrected?	YES	End.
Composite power supply PCB			NO	Replace the composite power supply PCB.

**15 DC power fails to turn on.**

Cause	Step	Checks	YES/NO	Action																												
AC power supply	1	Is AC power present between J201- and -2 on the composite power supply PCB?	NO	See "AC power fails to turn on."																												
Wiring, DC load	2	<p>Turn off the power switch, and disconnect J202 and J205 from the composite power supply PCB.</p> <p>Set the meter range to 30 VDC, and turn on the power switch. Is the voltage between the following terminals normal?</p> <table border="1" data-bbox="539 741 995 1099"> <thead> <tr> <th>Connector</th> <th>Pin</th> <th>Output</th> <th>Remarks</th> </tr> </thead> <tbody> <tr> <td rowspan="6">J202</td> <td>1</td> <td>GND</td> <td rowspan="6">To DC controller PCB</td> </tr> <tr> <td>2</td> <td>24V</td> </tr> <tr> <td>3</td> <td>5V</td> </tr> <tr> <td>4</td> <td>5V</td> </tr> <tr> <td>5</td> <td>GND</td> </tr> <tr> <td>6</td> <td>24V</td> </tr> <tr> <td rowspan="4">J205</td> <td>1</td> <td>-</td> <td rowspan="4">To main motor driver PCB</td> </tr> <tr> <td>2</td> <td>-</td> </tr> <tr> <td>3</td> <td>GND</td> </tr> <tr> <td>4</td> <td>24V</td> </tr> </tbody> </table> <p style="text-align: center;"><b>Table 11-401</b></p>	Connector	Pin	Output	Remarks	J202	1	GND	To DC controller PCB	2	24V	3	5V	4	5V	5	GND	6	24V	J205	1	-	To main motor driver PCB	2	-	3	GND	4	24V	YES	See "E000", "E001", "E002", or "E003".
Connector	Pin	Output	Remarks																													
J202	1	GND	To DC controller PCB																													
	2	24V																														
	3	5V																														
	4	5V																														
	5	GND																														
	6	24V																														
J205	1	-	To main motor driver PCB																													
	2	-																														
	3	GND																														
	4	24V																														
Fuse	3	<p>Is the fuse (FU102) on the composite power supply PCB blown?</p> <p>⎧ 120V model: 125 V, 5 V ⎫                  ⎨ 220/240V model: 250 V, 2.5 A ⎩</p>	YES	Remove the cause of the problem, and replace the fuse.																												
Composite power supply PCB			NO	Replace the composite power supply PCB.																												

**16 Pickup fails. (cassette)**

Cause	Step	Checks	YES/NO	Action									
Main motor (M1)	1	Does the main motor (M1) rotate when the Copy Start key is pressed?	NO	See "The main motor fails to rotate."									
Cassette	2	Is the cassette set correctly?	NO	Set the cassette correctly.									
Paper in cassette	3	Is the paper in the cassette placed correctly?	NO	Instruct the user on the correct method of placing paper.									
Pickup clutch solenoid (SL1), Cassette pickup solenoid (SL5)	4	Set the meter range to 30 VDC, and connect the meter probes to the following terminals. Does the voltage change to about 24 V in keeping with pickup operation?  <table border="1" style="margin-left: auto; margin-right: auto;"> <thead> <tr> <th></th> <th>+</th> <th>-</th> </tr> </thead> <tbody> <tr> <td>Pickup clutch solenoid (SL1)</td> <td>J109-4</td> <td>J109-3</td> </tr> <tr> <td>Cassette pickup solenoid (SL5)</td> <td>J132-2</td> <td>J132-1</td> </tr> </tbody> </table> <p style="text-align: center;"><b>Table 11-402</b></p>		+	-	Pickup clutch solenoid (SL1)	J109-4	J109-3	Cassette pickup solenoid (SL5)	J132-2	J132-1	NO	Check the wiring from the solenoid to the DC controller PCB; if normal, replace the solenoid.
	+	-											
Pickup clutch solenoid (SL1)	J109-4	J109-3											
Cassette pickup solenoid (SL5)	J132-2	J132-1											
Cassette spring	5	Is the force of the cassette spring within specification? (See p. 11-10.)	NO	Replace the cassette spring.									
DC controller PCB			YES	Replace the DC controller PCB.									

**17 Pickup fails. (multifeeder)**

Cause	Step	Checks	YES/NO	Action									
Wrong operation	1	Is the multifeeder selected on the control panel?	NO	Instruct the user on the correct way of operating the machine.									
Main motor (M1)	2	Does the main motor (M1) rotate when the Copy Start key is pressed?	NO	See "The main motor fails to rotate."									
Paper placement	3	Is the paper placed in the multifeeder correctly?	NO	Instruct the user on the correct way of placing paper.									
Multifeeder pickup solenoid (SL4), Pickup clutch solenoid (SL1)	4	Set the meter range to 30 VDC, and connect the meter probes as indicated. Does the voltage change to about 24 V in keeping with pickup operation?  <table border="1" style="margin-left: auto; margin-right: auto;"> <thead> <tr> <th></th> <th>+</th> <th>-</th> </tr> </thead> <tbody> <tr> <td>Multifeeder pickup solenoid (SL4)</td> <td>J109-8</td> <td>J109-7</td> </tr> <tr> <td>Pickup clutch solenoid (SL1)</td> <td>J109-4</td> <td>J109-3</td> </tr> </tbody> </table> <p style="text-align: center;"><b>Table 11-403</b></p>		+	-	Multifeeder pickup solenoid (SL4)	J109-8	J109-7	Pickup clutch solenoid (SL1)	J109-4	J109-3	NO	Check the wiring from the solenoid to the DC controller PCB; if normal, replace the solenoid in question.
			+	-									
Multifeeder pickup solenoid (SL4)	J109-8	J109-7											
Pickup clutch solenoid (SL1)	J109-4	J109-3											
DC controller PCB			YES	Replace the DC controller PCB.									

**18 The scanner fails to move forward.**

Cause	Step	Checks	YES/NO	Action
Cable	1	Is the scanner drive cable routed correctly?	NO	Route the cable correctly.
Scanner path	2	Is the scanner rail soiled? Move the scanner by hand. Does it move smoothly?	NO	Check the surface of the scanner rail for dirt, foreign matter, or object which may interfere.
Composite power supply PCB	3	Set the meter range to 30 VDC, and connect the meter probes to J202-2 (+) and -1 (-) on the composite power supply PCB. Is the meter reading about 24 V?	NO	See "DC power fails to turn on."
Pre-registration roller paper sensor (Q751)	4	Is the pre-registration roller paper sensor (Q751) normal? (For instructions on how to check the photointerrupters, see p. 11-51.)	NO	Check the wiring from J108 on the DC controller PCB to Q751; if normal, replace Q751.
Scanner/lens drive motor (M2)	5	Replace the scanner/lens drive motor (M2). Is the problem corrected?	YES	End.
DC controller PCB			NO	Replace the DC controller PCB.

**19 The registration roller fails to rotate.**

Cause	Step	Checks	YES/NO	Action
Main motor (M1)	1	Does the main motor (M1) start to rotate when the Copy Start key is pressed?	NO	See "The main motor fails to rotate."
Pre-registration roller paper sensor (Q751)	2	Is the pre-registration roller paper sensor (Q751) normal? (For instructions on how to check the photointerrupters, see p. 11-51.)	NO	Check the wiring from J108 on the DC controller PCB to Q751; if normal, replace Q751.
Registration roller spring clutch	3	Does the registration clutch solenoid (SL2) turn on for a moment after the Copy Start key is pressed?	NO	Check the position of the solenoid; if normal, check or replace the control ring.
Registration clutch solenoid (SL2)	4	Set the meter range to 30 VDC. Does the voltage between J109-6 (+) and -5 (-) on the DC controller PCB change to about 24 V for a moment after the Copy Start key is pressed?	YES	Check the wiring from J109 on the DC controller PCB to SL2; if normal, replace SL2.
DC controller PCB			NO	Replace the DC controller PCB.

**20 The blanking lamp fails to turn on.**

Cause	Step	Checks	YES/NO	Action
Side blanking PCB	1	Remove J106 from the DC control PCB, and set the meter range to 1 kΩ; then, connect the meter probes to J106-1 and -2 on the harness side. Is the meter reading about 20 Ω?	NO	Check the harness; if normal, replace the side blanking PCB.
DC controller PCB			YES	Replace the DC controller PCB.

**21 The pre-exposure lamp fails to turn on.**

Cause	Step	Checks	YES/NO	Action
Pre-exposure lamp PCB	1	Remove J121 from the DC control PCB, and set the meter range to 1 kΩ; then, connect the meter probes to J121-1 and -2 on the harness side. Is the meter reading about 4 Ω?	NO	Check the harness; if normal, replace the pre-exposure lamp PCB.
DC controller PCB			YES	Replace the DC controller PCB.

**22 The scanning lamp fails to turn on.**

Cause	Step	Checks	YES/NO	Action
Scanning lamp	1	Turn off the power switch, and disconnect the power plug from the power outlet. Is the scanning lamp (LA1) mounted correctly?	NO	Mount the scanning lamp correctly.
Fuse (FU1)	2	Set the meter range to 1 kΩ, and connect the meter probes to both terminals of the fuse (FU1). Does the index of the meter swing?	NO	Replace the fuse (FU1).
Lamp	3	Disconnect the connector J910 from the composite power supply PCB, and set the tester range to 1kΩ. Does the tester index swing when the probes are connected to J910-1 and J910-3 on the lamp side?	NO	Check the cable from the composite power supply PCB to the lamp; if normal, replace the lamp.
DC controller PCB	4	Replace the DC controller PCB. Is the problem corrected?	YES	End.
Composite power supply PCB			NO	Check the wiring between the DC controller PCB and the composite power supply PCB; if normal, replace the composite power supply PCB.



**23 The lens fails to turn on.**

Cause	Step	Checks	YES/NO	Action
Lens solenoid (SL3)	1	Does the lens solenoid (SL3) turn on when the power switch is turned on?	NO	Check the wiring from J109 on the DC controller PCB to SL3; if normal, replace SL3.
Lens cable, Pulley, Rail	2	Are the lens cable, pulley, and rail normal?	NO	Check the lens cable, pulley, and rail; as necessary, clean the cable and adjust its tension.
DC power supply	3	Set the meter range to the 30 VDC, and connect J202-2 (+) and -1 (-) on the composite power supply PCB. Is the meter reading about 24 V?	NO	See "DC power fails to turn on."
Scanner/lens drive motor (M2)	4	Replace the scanner/lens drive motor (M2). Is the problem corrected?	YES	End.
DC control PCB			NO	Replace the DC controller PCB.

**24 The fixing heater fails to turn on.**

Cause	Step	Checks	YES/NO	Action
-----	1	Is 'E000', 'E001', 'E002', or 'E003' indicated?	YES	See "E000", "E001", "E002", or "E003".
DC controller PCB	2	Replace the DC controller PCB. Is the problem corrected?	YES	End.
Composite power supply PCB			NO	Replace the composite power supply PCB.

**25 The "Add Paper" message fails to turn off.**

Cause	Step	Checks	YES/NO	Action
Cassette	1	Is the cassette set correctly?	NO	Set the cassette correctly.
DC power supply	2	Set the meter range to 30 VDC, and connect the meter probes to J202-2 (+) and -1 (-) on the composite power PCB. Is the meter reading about 24 V?	NO	See "The DC power fails to turn on."
Vertical path roller paper sensor (PS4)	3	Is the vertical path roller paper sensor (PS4) normal? (For instructions on how to check the photointerrupters, see p. 11-51.)	NO	Check the wiring from J132 on the DC controller PCB to PS4; if normal, replace the PS4.
Control panel PCB	4	Replace the control panel PCB. Is the problem corrected?	YES	End.
DC controller PCB			NO	Replace the DC controller PCB.

**26 The "Jam" message fails to turn off.**

Cause	Step	Checks	YES/NO	Action
Jam paper	1	Is the jam paper near any of the following sensors? <ul style="list-style-type: none"> <li>• Vertical path roller paper sensor (PS4)</li> <li>• Pre-registration roller paper sensor (Q751)</li> <li>• Delivery sensor (PS3)</li> </ul>	YES	Remove the jam paper.
Sensor	2	Is the sensor checked in step 1 normal? (For instructions on how to check the photointerrupters, see p. 11-51.)	NO	Check the wiring from the DC controller PCB to each sensor; if normal, replace the sensor in question.
DC controller PCB			YES	Replace the DC controller PCB.

## V. TROUBLESHOOTING FEEDING PROBLEMS

### A. Copy Paper Jam

Inside the machine, jams tend to occur in the following blocks:

- [1] Pickup block
- [2] Separation/feeding block
- [3] Fixing/delivery block

The troubleshooting procedures that follow are organized according to the location of a jam.

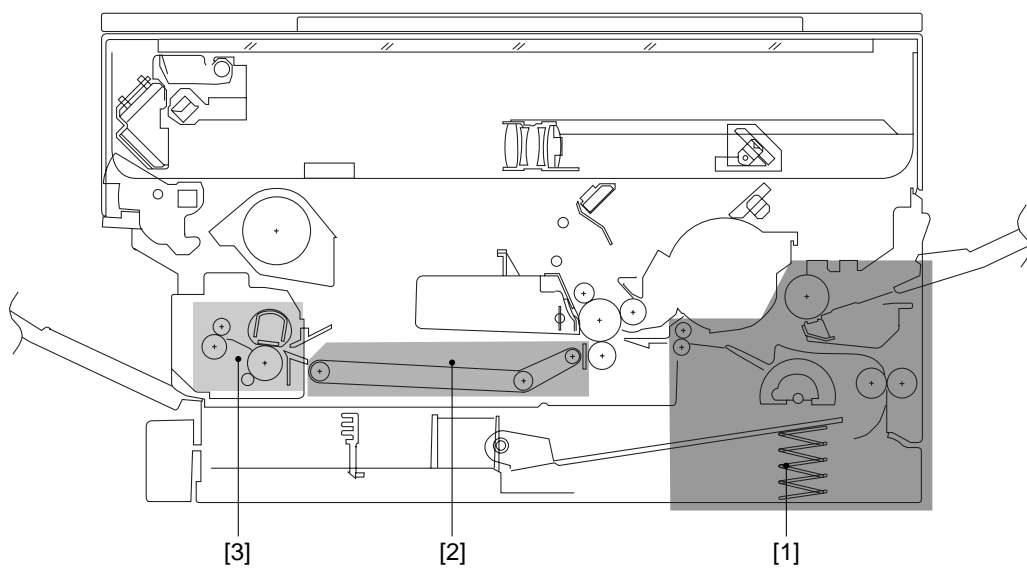

Figure 11-501

**1 Pickup Assembly**

Cause	Step	Checks	YES/NO	Action
-----	1	Does the problem occur when the cassette is selected as the source of paper?	NO	Go to step 5.
Cassette	2	Is the cassette set correctly?	NO	Set the cassette correctly.
Copy paper	3	Is the copy paper curled or wavy?	YES	Replace the copy paper. Instruct the user on the correct method of storing paper.
Copy paper	4	Try paper recommended by Canon. Is the problem corrected?	YES	Ask the user to use recommended paper.
DC controller PCB, Pickup clutch	5	Does the pickup roller of the pickup assembly of the selected source (cassette, manual feeder) rotate during a copying run?	NO	See "Pickup fails" for the source of paper in question.
Registration roller drive assembly	6	Does the registration roller operate normally?	NO	See "The registration roller fails to rotate."
Vertical path roller paper sensor (PS4)	7	Does the vertical path roller paper sensor operate normally?	NO	Replace the sensor or the lever.
Pickup roller, Vertical path roller, Roll			YES	Check the roller for wear and deformation, and the roll for attachment.

**2 Separation/Feeding Assembly**

Cause	Step	Checks	YES/NO	Action
Copy paper	1	Try paper recommended by Canon. Is the problem corrected?	YES	Ask the user to use recommended paper.
	2	Is the copy paper curled, wavy, or otherwise deformed?	YES	Replace the paper.
Feeding assembly	3	Is there foreign matter in the feeding assembly?	YES	Instruct the user on the correct method of storing paper.
Feed belt, Roller	4	Is the feed belt rotating properly?	NO	Remove the foreign matter.
Static eliminator	5	Is the static eliminator soiled with toner or the like?	YES	Check the belt and the roller.
Pre-registration roller paper sensor (Q751)	6	Does the pre-registration roller paper sensor operate normally?	NO	Replace the sensor or the lever.
Registration roller	7	Is the registration roller worn, deformed, or soiled?	YES	Clean the static eliminator. If dirt is found, clean with alcohol; if wear or deformation is found, replace it.
Registration-related spring, Spring clutch of registration assembly			NO	1. Check the spring used to control registration. 2. Check the spring clutch of the registration assembly.

**3 Fixing/Delivery Assembly**

Cause	Step	Checks	YES/NO	Action
Inlet guide	1	Is the fixing inlet guide soiled with toner?	YES	Clean the guide with solvent.
Fixing lower roller, Fixing film	2	Is the fixing lower roller or the fixing film deformed or scratched?	YES	Replace the roller or the fixing assembly upper unit.
Delivery paper detecting lever	3	Does the delivery detecting lever move smoothly?	NO	Make adjustments so that it moves smoothly.
Delivery sensor (PS3)	4	Does the delivery sensor operate normally?	NO	Replace the sensor.
Delivery roller drive assembly	5	Does the delivery roller operate smoothly?	NO	Check the delivery roller drive assembly
Leading edge margin			YES	Check the leading edge of copy paper for margin.

## B. Faulty Feeding

### 1 Double-Feeding

Cause	Step	Checks	YES/NO	Action
Cassette	1	Is the copy paper placed under the claw properly?	NO	Place the copy paper properly.
	2	Push down the copy paper inside the cassette. Does it move up when let go with its end coming under the claw?	NO	1. Check the copy paper width. 2. Check the position of the side guide plate of the cassette. (universal cassette only) 3. Measure the force of the spring of the cassette; if faulty, replace the cassette spring.
	3	Is the sheets of paper placed in the cassette uneven?	YES	Even out the sheets in the cassette.
Copy paper	4	Is the paper of a type recommended by Canon?	NO	Ask the user to use recommended paper.
Claw (cassette)			YES	Check the claw for deformation.

### 2 Wrinkles

Cause	Step	Checks	YES/NO	Action
Pickup assembly, Vertical path roller, Registration roller	1	Turn off the power while copy paper is moving through the feeding assembly. Is the copy paper wrinkled or found askew?	YES	<ul style="list-style-type: none"> <li>• Check the pickup assembly.</li> <li>• Check the vertical path roller.</li> <li>• Check the registration roller.</li> </ul>
Copy paper	2	Try fresh paper. Is the problem corrected?	YES	The paper is moist. Instruct the user on the correct method of storing paper.
	3	Try paper of a type recommended by Canon. Is the problem corrected?	YES	Ask the user to use recommended paper.
Fixing assembly	4	Is the inlet guide soiled with toner?	NO	Check the fixing assembly.
Inlet guide			YES	Clean the inlet guide with solvent.

## VI. ARRANGEMENT AND FUNCTIONS OF ELECTRICAL PARTS

### A. Sensors and Solenoids

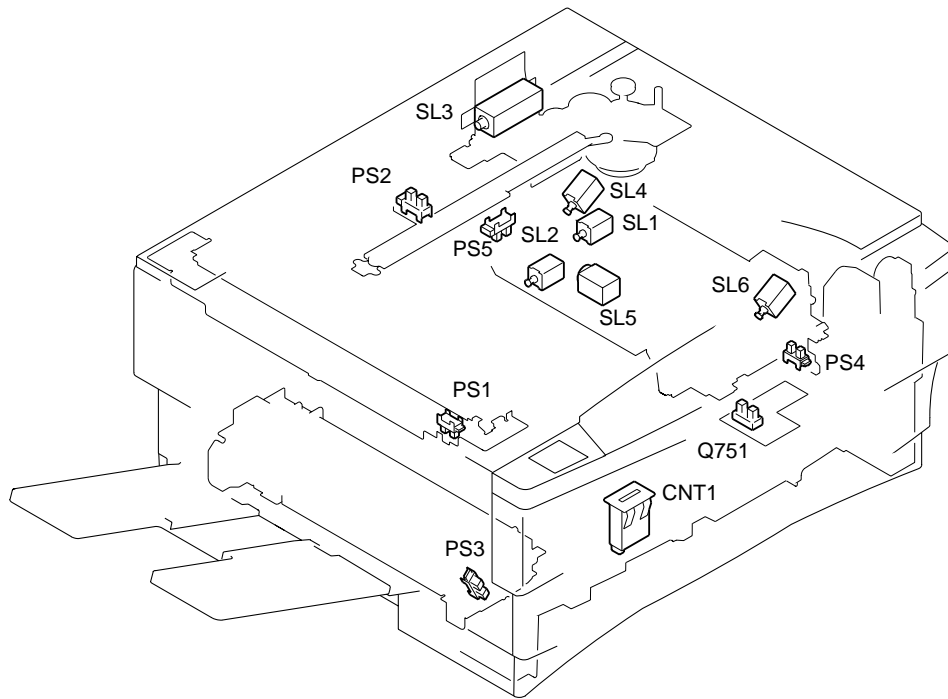
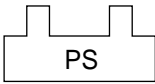

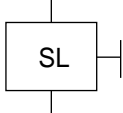

Figure 11-601

Symbol	Name	Notation	Description	Remarks
 PS	Photointerrupters	PS1	Scanner home position detection	
		PS2	Lens home position detection	
		PS3	Delivery assembly paper detection	
		PS4	Vertical path assembly paper detection	
		PS5	Waste toner detection	
		Q751	Pre-registration roller paper detection	
 CNT	Counter	CNT1	Total copy counter	
 SL	Solenoid	SL1	Pickup clutch solenoid	
		SL2	Registration clutch solenoid	
		SL3	Lens solenoid	
		SL4	Multifeeder pickup solenoid	
		SL5	Cassette pickup solenoid	
		SL6	Primary charging roller cleaning solenoid	

## B. Switches

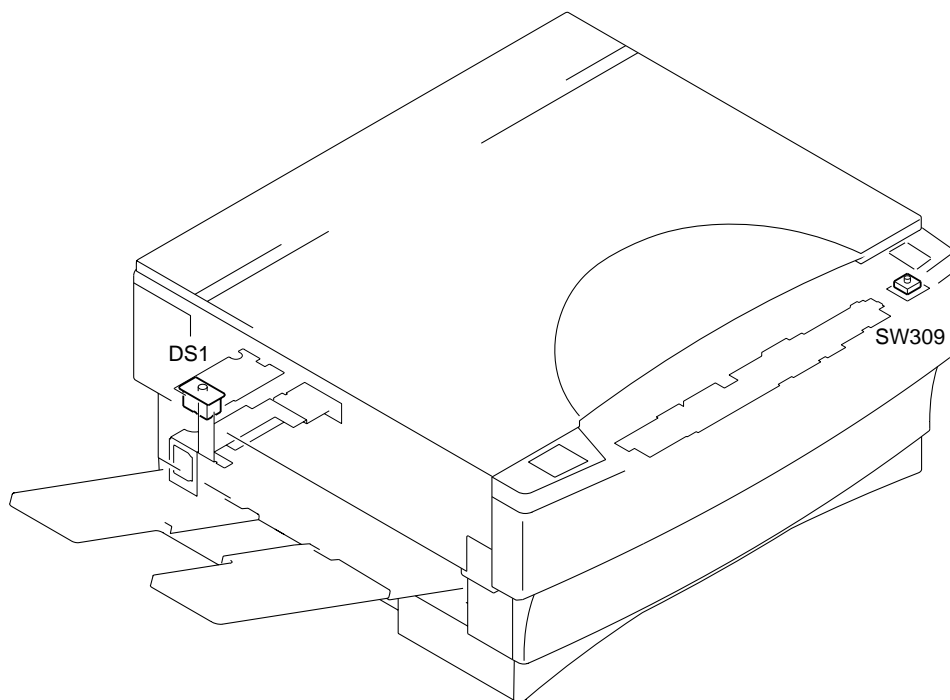
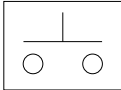

Figure 11-602

Symbol	Name	Notation	Description	Remarks
	Switch	DS1 SW309	Door switch Power switch	



C. Lamp, Heater, Motor, Etc.

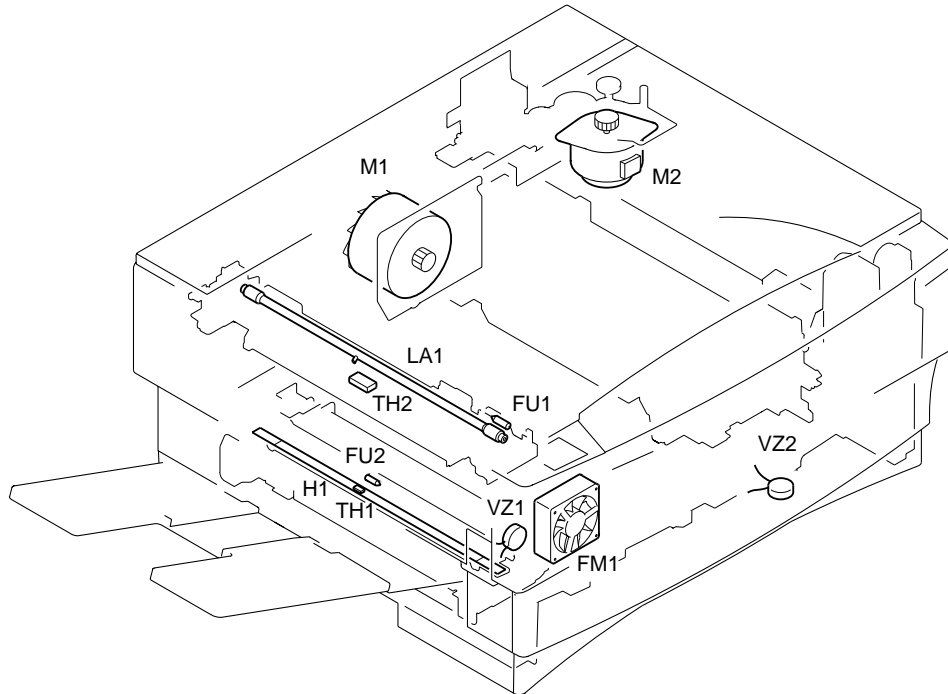

Figure 11-603

Symbol	Name	Notation	Description	Remarks
	Lamp	LA1	Scanning lamp	
	Heater	H1	Fixing heater	
	Motor	M1 M2	Main motor Scanner/lens drive motor	
	Fan motor	FM1	Scanner cooling fan	
	Thermistor	TH1 TH2	Fixing heater temperature detection Scanner temperature detection	
	Thermal fuse	FU1 FU2	Lamp overheating detection Fixing heater overheating detection	
	Varistor	VZ1 VZ2	Fixing film varistor Transfer guide varistor	

D. PCBs

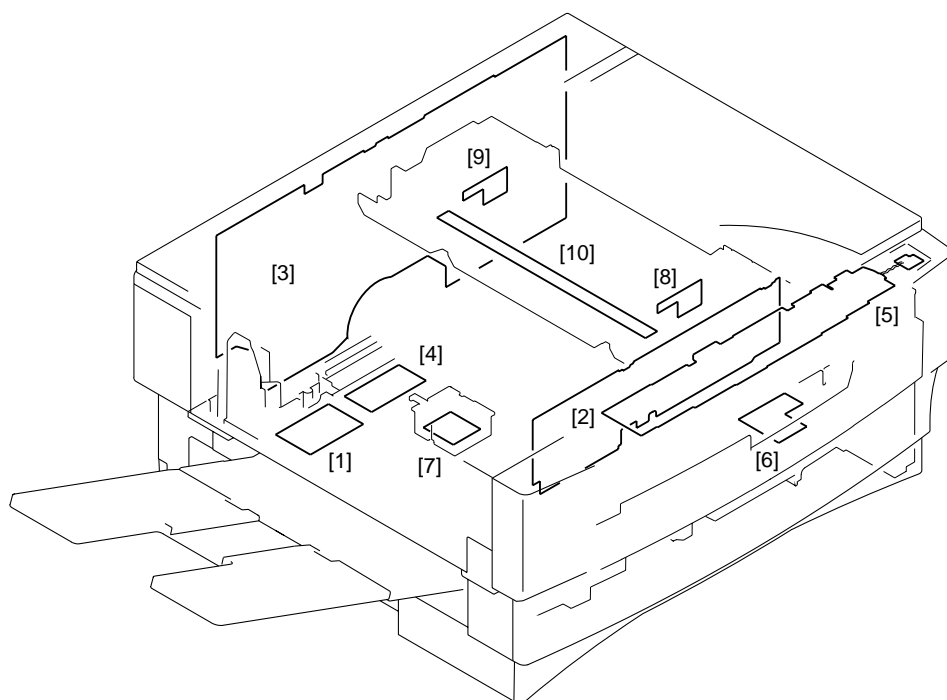

Figure 11-604

Ref.	Name	Description
[1]	Noise filter PCB	Removes noise from the power supply.
[2]	DC controller PCB	Controls sequence of operations.
[3]	Composite power supply PCB	Supplies DC power, generates high voltage, and controls the scanning lamp.
[4]	High-voltage contact PCB	Makes an electrical connection between the machine top and bottom.
[5]	Control panel PCB	Provides copying insurrections/indications.
[6]	Sensor PCB	Detects paper in front of the registration roller.
[7]	AE sensor PCB	Detects the density of originals.
[8]	Blanking PCB (front)	Used for blanking exposure.
[9]	Blanking PCB (rear)	Used for blanking exposure.
[10]	Pre-exposure PCB	Used for pre-exposure.

E. ADF

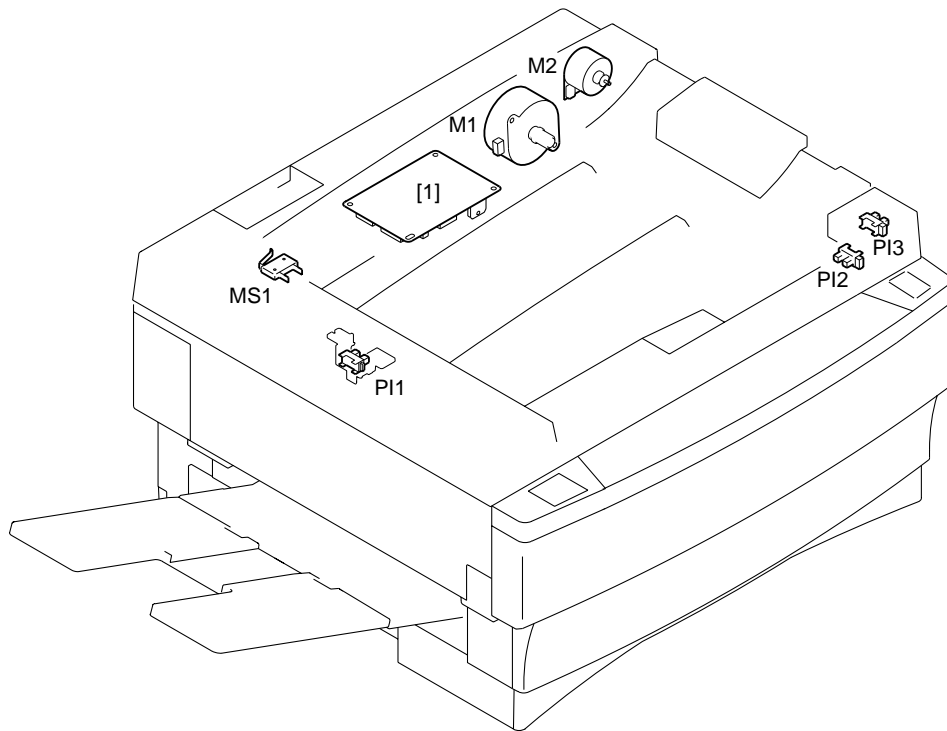
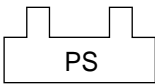
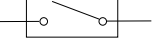
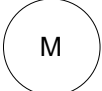



Figure 11-605

Symbol	Name	Notation	Description	Remarks
 PS	Photointerrupter	PI1 PI2 PI3	Delivery paper detection Registration roller paper detection Original placement detection	
	Microswitch	MS1	ADF open/close switch	
 M	Motor	M1 M2	Belt motor Pickup motor	
[1]	ADF controller PCB		Controls sequence of operations	

## F. Variable Resistors (VR) and Check Pins by PCB

Of the variable resistors (VR) and check pins, those needed in the field are discussed herein. Those not found in the discussions are for the factory only, requiring special tools and adjustment to an extremely accuracy. Do not touch them in the field.

**Caution:**

- VRs that may be used in the field ..... 
- VRs that must not be used in the field ..... 

### 1. DC Controller PCB

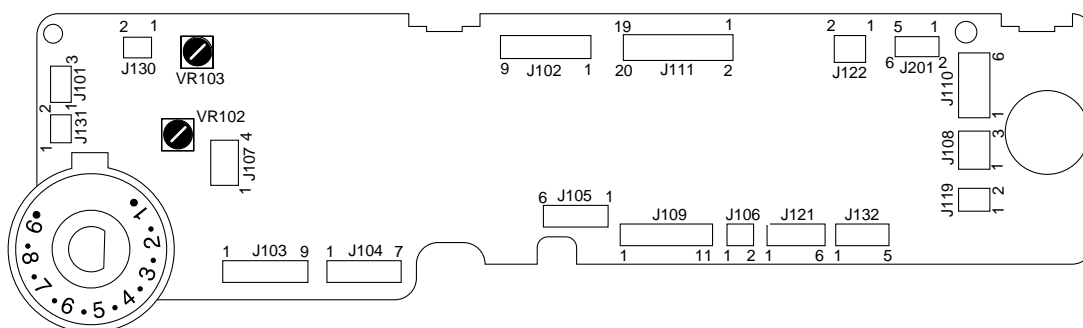

Figure 11-606

### 2. Composite Power Supply PCB

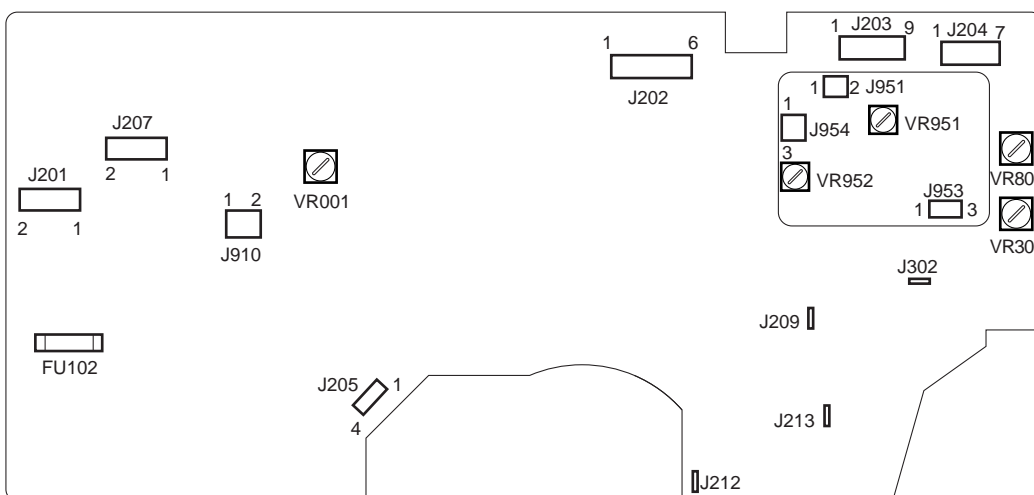

Figure 11-607

3. ADF Controller PCB

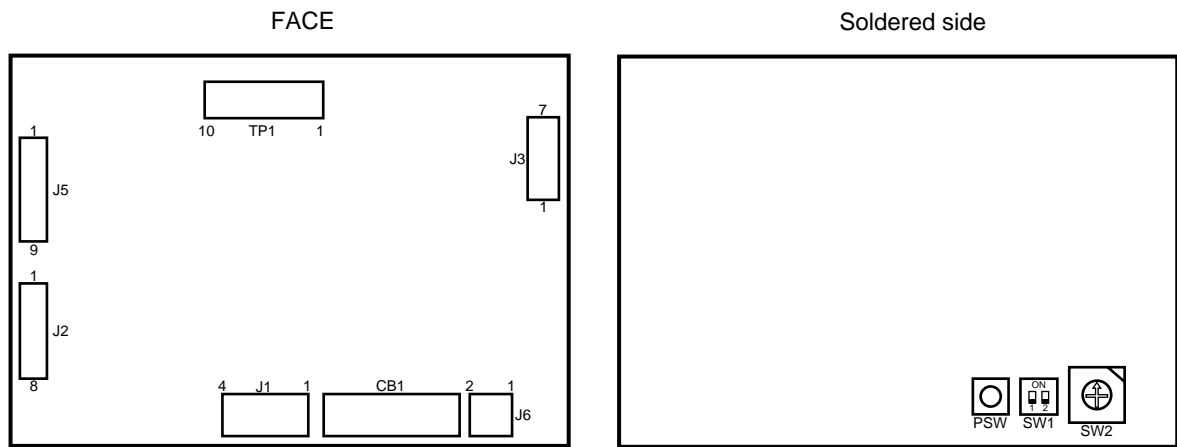

Figure 11-608

## VII. SERVICE MODE

### A. Outline

The machine's service mode is divided into the following four types:

Notation	Item
30	Adjustment mode
40	Operation/inspection mode
50	Machine settings mode
60	Counter mode

Table 11-701

### B. Using Service Mode

#### 1. Starting Service Mode

- 1) Open the machine's top unit, and remove the two screws [1]; then, detach the front upper cover [2].

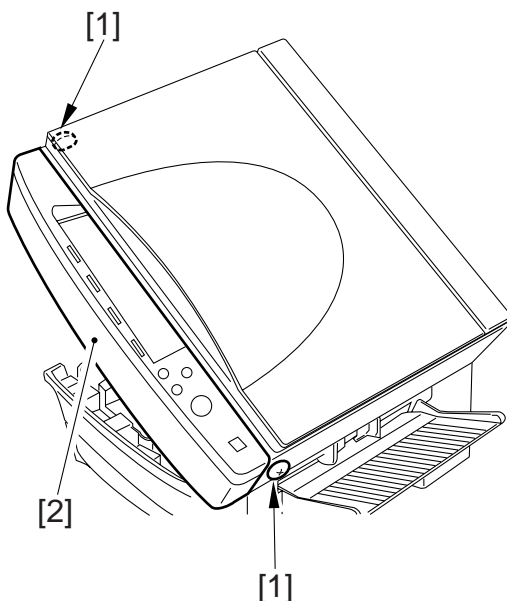
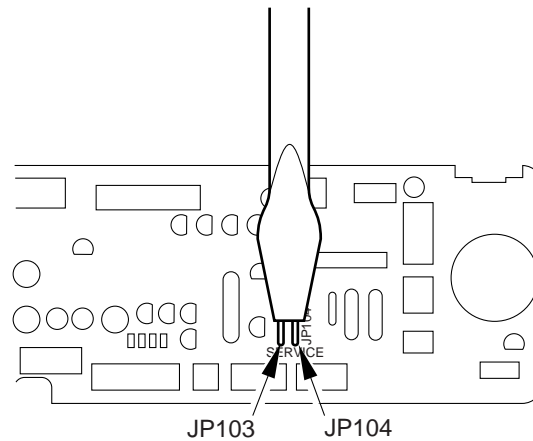

Figure 11-701

**Caution:**

A flexible cable for the control panel is connected to the front upper cover. Disconnect the cable from the DC controller.

- 2) Close the machine's top unit, and connect the flexible cable from the control to the DC controller PCB; then, turn on the power switch.
- 3) Short JP103 and JP104 on the DC controller PCB with a screwdriver.
  - The display will indicate 'F'.



**Figure 11-702**

- 4) While the display indicates 'F', stop shorting JP103 and JP104.

## **2. Ending Service Mode**

- 1) Press the Clear/Stop key.

## **3. Selecting an Item**

- 1) While the display is indicating 'F', press the +/- key to select the item to check or adjust.
  - The 10s digit will flash.
- 2) Press the Copy Start key to start the item.

#### 4. Clearing the Error Code from Memory

If 'E000', 'E001', 'E002', or 'E003' is indicated, remove the cause of the error, and clear the memory.

- 1) Turn on the power while shorting JP103 and JP104 on the DC controller PCB with a screwdriver.
  - The display will indicate 'F'.

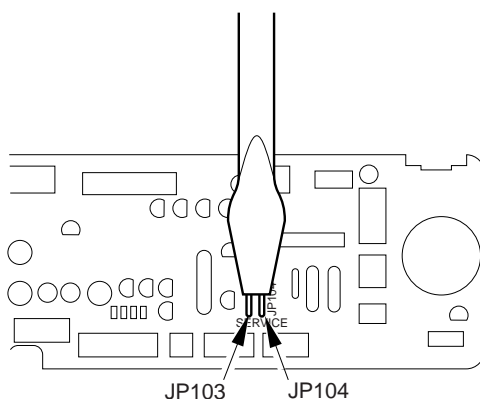

Figure 11-703

- 2) Turn off and then on the power switch to check the copying operation.

**Caution:**

When a fault associated with 'E000', 'E001', 'E002', or 'E003' is detected, the power will automatically turn off. It will still turn off even when turned on without removing the fault.

To find out which code turned off the power, disconnect J207 from the composite power supply PCB, and turn on the power.

Figure 11-704 shows the label attached behind the front upper cover. At the factory, each individual machine is adjusted, and its adjustment values are recorded on the label.

If you have entered any new value in the field, be sure to record it on the label. If you have replaced the DC controller PCB, be sure to enter the values recorded on the label in service mode.

If you have replaced the drum unit, composite power supply PCB, or pre-exposure PCB, on the other hand, be sure to enter the values recorded on the label of the appropriate part. Then, record these values on the service label.

30	REGIST				
31	LE_BLANK				
32	PRIMARY				
33	IP_OFST				
34	PW_OFST				
35	IP_ADJ				
36	LENS_ADJ				
37	PREX_LP				
38	LAMP_ADJ				

FB5-2777

Figure 11-704



## C. Adjustment Mode (30)

- 1) Press the +/- key to select an item, and press the Copy Start key.
  - The existing setting of the item will flash.
- 2) Press the +/- key to change the settings.
- 3) Press the AE key to store the new setting.
  - The setting will stop flashing and remain on.
  - A press on the Copy Start key will start copying operation.
- 4) As necessary, press the Clear/Stop key to return to item selection.

### Caution:

If you have changed the setting of '34' or '37', be sure to execute 'U7' in user mode (installation/drum replacement mode).

Notation	Item	Settings	Description
30	Leading edge margin adjustment (REGIST)	0-99	A higher setting will delay the copy paper in relation to the image, reducing the margin. Unit: 0.24 mm
31	Leading edge non-image width adjustment (LE_BLANK)	0-99	A higher setting will increase the leading edge non-image width. Unit: 0.24 mm
32	Primary charging output voltage correction (PRIMARY)	0-30	Use it to correct the output voltage determined by APVC. (If you have replaced the drum unit, be sure to enter the value recorded on the label.)
33	APVC measurement current correction (IP_OFST)	0-99	Correct the current value for APVC measurement. (If you have replaced the drum unit, be sure to enter the value recorded on the label.)
34	APVC measurement voltage correction (PW_OFST)	0-30	Use it to correct the level of voltage applied during APVC measurement. (If you have replaced the composite power supply PCB, enter the value recorded on the PCB.)
35	APVC measurement current correction (IP_ADJ)	0-30	Use it to correct the level of current measured during APVC measurement. (If you have replaced the composite power supply PCB, enter the value recorded on the PCB.)
36	Ratio fine adjustment (LENS_ADJ)	0-30	Use it to correct the lens position. (Do not use it in the field.)
37	Pre-exposure lamp output adjustment (PREX_LP)	0-99	Use it to adjust the intensity of the pre-exposure lamp. (If you have replaced the pre-exposure lamp, enter the value recorded on the label attached to the lamp PCB.)
38	Lamp intensity adjustment (LAMP_ADJ)	0-99	Use it to adjust the intensity of the scanning lamp. Unit: 0.15 V (approx.; 120 V) 0.30 V (approx.; 220/240 V)

Table 11-702

## D. Operation/Inspection Mode (40)

- 1) Select an appropriate item using the +/- key; then, press the Copy Start key to execute it.
  - The item is flashed.
  - If the mode is designed to stop automatically, item selection will automatically return at the end.
  - As necessary, press the Clear/Stop key to return item selection.

Notation	Item	Description
40	AE adjustment mode	The main motor rotates, and the scanner moves forward. The halogen lamp will turn on, and the reading of the AE sensor will appear in the display.
41	Toner supply mode	The developing assembly is supplied with toner. (If you have replaced the developing assembly, execute this mode so that toner will be supplied from the toner cartridge to the developing assembly.) <ul style="list-style-type: none"> <li>• In about 10 to 60 sec, the operation will stop automatically.</li> </ul>
42	Back-up RAM clear	<ol style="list-style-type: none"> <li>(1) Press the +/- key to select '42'.                             <ul style="list-style-type: none"> <li>• '4' will flash in the 10s digit.</li> </ul> </li> <li>(2) Press the Copy Start key.                             <ul style="list-style-type: none"> <li>• '42' will flash.</li> </ul> </li> <li>(3) Press the AE key.                             <ul style="list-style-type: none"> <li>• The display will indicate 'EE'.</li> </ul> </li> <li>(4) Press the Copy Start key.                             <ul style="list-style-type: none"> <li>• '4' in the 10s digit will flash.</li> </ul> </li> <li>(5) Turn off and then on the power switch.                             <ul style="list-style-type: none"> <li>• The back-up RAM will be cleared, and the settings will be returned to defaults.</li> </ul> </li> </ol> <p>Reference: _____</p> <p>If you have to stop the RAM clear mechanism, press the Clear/Stop key before starting step (4).</p> <p>The RAM will be cleared when step (4) is executed.</p> <p>_____</p>

Table 11-703

## E. Machine Settings Mode (50)

- 1) Press the +/- key to select an item, and press the Copy Start key.
  - The setting will flash.
- 2) Press the +/- key to change the setting.
- 3) Press the AE key to store the new setting.
  - The setting will stop flashing, and remain on.
- 4) As necessary, press the Clear/Stop key to return to item selection.

Notation	Item	Description
50	Copy count upper limit setting	The upper limit may be between 1 and 100. Setting: 0 to 99 (If set to '0', however, the upper limit will be 100.)
51	Density adjustment mode at power-on	Select AE mode or manual mode for density adjustment at power-on: • 0: AE • If other than '0', manual mode.

**Table 11-704**

## F. Counter Mode (60)

- 1) Press the +/- key to select an item, and press the Copy Start key.
  - The counter reading will be indicated.
- 2) As necessary, press the Clear/Stop key to return to item selection.

Notation	Item	Description
60	Counter for the drum unit currently in use	Unit: 1000 (sheets)
61	Counter for the most recent drum unit	Unit: 1000 (sheets)
62	Counter for the second most recent drum unit	Unit: 1000 (sheets)

**Table 11-705**

### Reference:

When '74' (installation toner stirring mode under 'U7" of user mode) is executed, the counter reading entered under '73' (preceding mode) will be entered to item 60. The counter readings so far retained will shift to represent their respective previous drum units.

(In other words, the count reading entered when executing 'U7' will be for item 60; count reading for item 60 will be for item 61; count reading for item 61 will be for item 62; count reading for item 62 will be deleted.)

## VIII. SELF DIAGNOSIS

The microprocessor on the machine's DC controller PCB is equipped with a self diagnostic mechanism that checks the condition of the machine (particularly, sensors) and indicates an error code in the count/ratio indicator on the control panel upon detection of a fault.

In the case of 'E001', 'E0' and '01' are flashed alternately.

Code	Cause	Description
<b>E000</b>	<ul style="list-style-type: none"> <li>The thermistor (TH1) is faulty.</li> <li>The fixing heater (H1) is faulty.</li> <li>The thermal fuse (FU2) has blown.</li> <li>The DC controller PCB is faulty.</li> <li>The composite power supply PCB is faulty.</li> </ul>	<ul style="list-style-type: none"> <li>The temperature detected by the thermistor (TH1) does not reach 65°C 1.5 sec after the Copy Start key has been pressed.</li> <li>The temperature detected by the thermistor (TH1) does not reach 150°C 4 sec after the Copy Start key has been pressed.</li> </ul>
<b>E001</b>	<ul style="list-style-type: none"> <li>The thermistor (TH1) is faulty.</li> <li>The DC controller PCB is faulty.</li> <li>The composite power supply PCB is faulty.</li> </ul>	<ul style="list-style-type: none"> <li>The temperature detected by the thermistor (TH1) exceeds 230°C.</li> <li>The temperature detected by the thermistor (TH1) exceeds by 30°C or more.</li> <li>The temperature detected by the thermistor (TH1) registers an increase of 100°C or more within 1 sec.</li> <li>The temperature detected by the thermistor (TH1) registers an increase of 40°C or more after it has reached 100°C during standby.</li> </ul>
<b>E002</b>	<ul style="list-style-type: none"> <li>The thermistor (TH1) is faulty.</li> <li>The fixing heater (H1) is faulty.</li> <li>The thermal fuse (FU2) has blown.</li> <li>The DC controller PCB is faulty.</li> <li>The composite power supply PCB is faulty.</li> </ul>	<ul style="list-style-type: none"> <li>The temperature detected by the thermistor (TH1) has exceeded 150°C during copy operation and maximum power is applied for 10 to 14 sec thereafter.</li> </ul>
<b>E003</b>	<ul style="list-style-type: none"> <li>The thermistor (TH1) is faulty.</li> <li>The fixing heater (H1) is faulty.</li> <li>The thermal fuse (FU2) has blown.</li> <li>The DC controller PCB is faulty.</li> <li>The composite power supply PCB is faulty.</li> </ul>	<ul style="list-style-type: none"> <li>The temperature detected by the thermistor (TH1) drops to and remains 150°C or lower after it has reached 160°C.</li> </ul>
<b>E010</b>	<ul style="list-style-type: none"> <li>The main motor (M1) is fault.</li> <li>The DC controller PCB is faulty.</li> </ul>	<ul style="list-style-type: none"> <li>The rotation of the main motor deviates (indicated by MLOCK=0) for 1 sec or more while the main motor drive signal (MMD=1) is being generated.</li> </ul>
<b>E030</b>	<ul style="list-style-type: none"> <li>The counter has an open circuit.</li> </ul>	<ul style="list-style-type: none"> <li>The counter drive signal is not generated when the counter is driven.</li> <li>The counter drive signal is not '0' when the counter is not driven.</li> </ul>

Code	Cause	Description
<b>E064</b>	<ul style="list-style-type: none"> <li>The composite power supply PCB is faulty.</li> <li>The DC controller PCB is faulty.</li> </ul>	<ul style="list-style-type: none"> <li>The actual output value of the composite power supply high voltage is different from the setting value twice in succession.</li> </ul>
<b>(E202)</b> The keys on the control panel are locked with error code indication.	<ul style="list-style-type: none"> <li>The scanner home position sensor (PS1) is faulty.</li> <li>The scanner/lens drive motor (M2) is faulty.</li> <li>The DC controller PCB is faulty.</li> </ul>	<ul style="list-style-type: none"> <li>The scanner home position is not detected within 10 sec after the scanner has turned on.</li> <li>The scanner does not leave the home position after it has turned on.</li> </ul>
<b>E210</b>	<ul style="list-style-type: none"> <li>The lens home position sensor (PS2) is faulty.</li> <li>The scanner/lens drive motor (M2) is faulty.</li> <li>The lens cable is faulty.</li> <li>The DC controller PCB is faulty.</li> </ul>	<ul style="list-style-type: none"> <li>The lens hoe position is not detected after the lens has moved the maximum travel distance.</li> <li>The lens does not leave the home position after it has turned on.</li> </ul>
<b>E220</b>	<ul style="list-style-type: none"> <li>The scanning lamp (LA1) is faulty.</li> <li>The DC controller PCB is faulty.</li> <li>The composite power supply PCB is faulty.</li> </ul>	<ul style="list-style-type: none"> <li>The lamp ON detection signal is not detected for 1 sec or more in the presence of the scanning lamp On signal.</li> <li>The lamp ON detection signal is detected for 1 sec or more in the absence of the scanning lamp ON signal.</li> </ul>
<b>E240</b>	<ul style="list-style-type: none"> <li>The DC controller PCB is faulty.</li> <li>The composite power supply PCB is faulty.</li> </ul>	<ul style="list-style-type: none"> <li>A fault in the communication between DC controller PCB and composite power supply PCB is detected.</li> </ul>
<b>E261</b>	<ul style="list-style-type: none"> <li>The frequency of the power supply is faulty.</li> <li>The composite power supply PCB is faulty.</li> </ul>	<ul style="list-style-type: none"> <li>The interval between zero-cross signals is in excess of the allowed interval.</li> </ul>
<b>E400</b>	<ul style="list-style-type: none"> <li>Data communication between the copier and the ADF (faulty)</li> </ul>	<ul style="list-style-type: none"> <li>The communication with the copier is interrupted for 5 sec or more; the communication is monitored at all times.</li> </ul>
<b>E803</b>	<ul style="list-style-type: none"> <li>The DC controller PCB is faulty.</li> <li>The composite power supply PCB is faulty.</li> </ul>	<ul style="list-style-type: none"> <li>During a copying run, the +24 V power deviates from the control value by <math>\pm 20\%</math>.</li> </ul>

**Caution:**

1. If the self-diagnosis has turned on, turn off the power switch to reset the machine.  
In the case of 'E000', 'E001', 'E002', or 'E003', however, the machine must be reset as follows: this consideration is to prevent feeding power to the fixing heater otherwise occurring if the thermistor has an open circuit:
2. In the case of 'E000', 'E001', 'E002', 'E003', or 'E220', the machine will turn off in 1.5 sec for 'E000' through 'E003' and in 2 sec for 'E220'.
3. In the case of 'E000', 'E001', 'E002', or 'E003', perform the following steps:
  - 1) Turn off the power switch, and short circuit JP103 and JP104 on the DC controller PCB with a screwdriver or the like.
    - The count/ratio indicator on the control panel turns on 'F'.

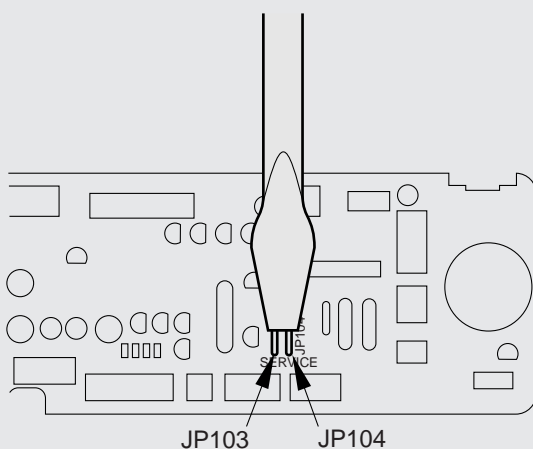

**Figure 11-801**

- 2) When 'F' has turned on, stop shorting circuit JP103 and JP104.
- 3) Turn off and then on the machine.

---

---

# APPENDIX

---

---

A.	GENERAL TIMING CHART .....	A-1	I.	SENSOR CIRCUIT DIAGRAM .....	A-32
B.	SIGNALS AND ABBREVIATIONS .....	A-3	J.	NOISE FILTER CIRCUIT DIAGRAM .....	A-33
C.	GENERAL CIRCUIT DIAGRAM .	A-5	K.	HIGH VOLTAGE CONTACT CIRCUIT DIAGRAM .....	A-34
D.	DC CONTROLLER CIRCUIT DIAGRAM .....	A-7	L.	BLANK EXPOSURE (front) CIRCUIT DIAGRAM .....	A-35
E.	ADF CONTROLLER CIRCUIT DIAGRAM .....	A-15	M.	BLANK EXPOSURE (rear) CIRCUIT DIAGRAM .....	A-36
F.	COMPOSITE POWER SUPPLY CIRCUIT DIAGRAM.....	A-19	N.	PRE-EXPOSURE CIRCUIT DIAGRAM .....	A-37
G.	CONTROL PANEL CIRCUIT DIAGRAM .....	A-29	O.	SPECIAL TOOLS .....	A-38
H.	AE SENSOR CIRCUIT DIAGRAM .....	A-31	P.	SOLVENTS/OILS .....	A-39





# A. GENERAL TIMING CHART

## 1. COPYBOARD TYPE

(A4, 2 copies, DIRECT, from cassette)



▨ : Scanner/lens drive motor (reverse)

## 2. ADF TYPE

(A4, 2 copies, DIRECT, from cassette)

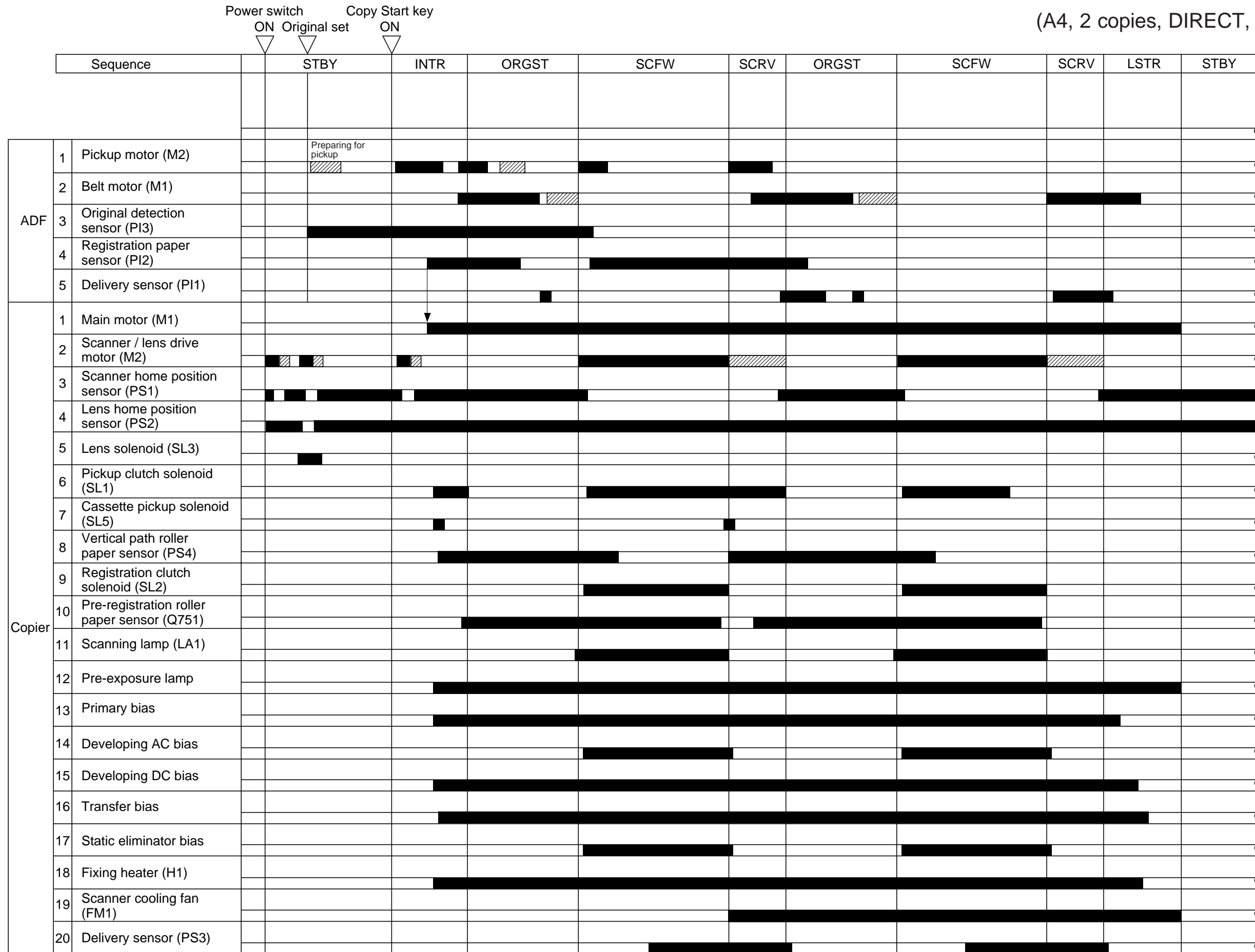

▨ : Scanner/lens drive motor (reverse)/Pickup motor (reverse)/Belt motor (reverse)

## B. SIGNALS AND ABBREVIATIONS

What follows below is a list of signals and abbreviations used in the chapters of the manual and circuit diagrams. The abbreviations within parentheses represent analog signals, which cannot be expressed in terms of '1' or '0'.

### 1. Signals

ACBIAS	AC BIAS OSCILLATION signal
[AE]	AE SENSOR OUTPUT signal
AEREF	AE SENSOR REFERENCE signal
BIAS_PWM	DC BIAS CONTROL signal
BIAS_S	DC BIAS MONITOR signal
CLK32K	TRANSFORMER CONTROL signal
CPUSD	CASSETTE PICKUP SOLENOID DRIVE signal
DPD	DELIVERY PAPER DETECTION signal
DV_AC_ON	DEVELOPING AC BIAS ON signal
DV_DC_ON	DEVELOPING DC BIAS ON signal
FM1D	SCANNER COOLING FAN DRIVE signal
HEAT_ERR	FIXING HEATER ERROR signal
HEAT_OFF	FIXING HEATER OFF signal
HEAT_PWM	FIXING HEATER DUTY signal
HEAT_TRG	FIXING HEATER DRIVE signal
LAMP_DETECT	LAMP ACTIVATION DETECTION signal
LAMP_ON	SCANNING LAMP ACTIVATION signal
LHP	LENS HOME POSITION signal
LNSLD	LENS SOLENOID DRIVE signal
MFSLD	MULTIFEEDER PICKUP SOLENOID DRIVE signal
MLOCK	MAIN MOTOR CONSTANT SPEED signal
MMCLK	MAIN MOTOR CLOCK PULSE signal
MMD	MAIN MOTOR DRIVE signal
P_C_S	DC BIAS CURRENT DETECTION signal
PCSLD	DC VOLTAGE MONITOR signal
PDC_PWM	DC BIAS CONTROL signal
PDC_S	DC VOLTAGE MONITOR signal
PDP	VERTICAL PATH ROLLER PAPER DETECTION signal
PEXP	PRE-EXPOSURE LAMP CONTROL signal
PR_DC_ON	PRIMARY CHARGING DC BIAS ON signal
PUSLD	PICKUP CLUTCH SOLENOID DRIVE signal
PWM_1KHz	SCANNING LAMP INTENSITY ADJUSTMENT signal
PWOFF	POWER SWITCH OFF signal
RGSLD	REGISTRATION CLUTCH SOLENOID DRIVE signal
RLOFF	RELAY DRIVE signal
RPD	PRE-REGISTRATION ROLLER PAPER DETECTION signal
SB_LP	SIDE BLANK EXPOSURE LAMP ON signal
SC_A	SCANNER MOTOR PULSE signal A
SC_B	SCANNER MOTOR PULSE signal B
SC_COM	SCANNER MOTOR DRIVE signal
SCHP	SCANNER HOME POSITION signal
TCNTD	TOTAL COPY COUNTER DRIVE signal
T_FEEDBACK	TRANSFER BIAS VOLTAGE DETECTION signal
T_FW_DRV	TRANSFER DC BIAS CONTROL signal

T_FW_ON	TRANSFER DC BIAS ON signal
T_FW_S	TRANSFER CURRENT DETECTION signal
TNFULL	WASTE TONER DETECTION signal
TNMONI	TONER LEVEL signal
T_REV_ON	TRANSFER POSITIVE DC BIAS ON signal
[TH1]	FIXING THERMISTOR signal
[TH2]	SCANNER THERMISTOR signal

### 2. Abbreviations

AER	AE (MEASUREMENT) ROTATION
INTR	INITIAL ROTATION
LSTR	LAST ROTATION
SCFW	SCANNER FORWARD
SCRV	SCANNER REVERSE
STBY	STANDBY



# C. GENERAL CIRCUIT DIAGRAM

## 1. Copier

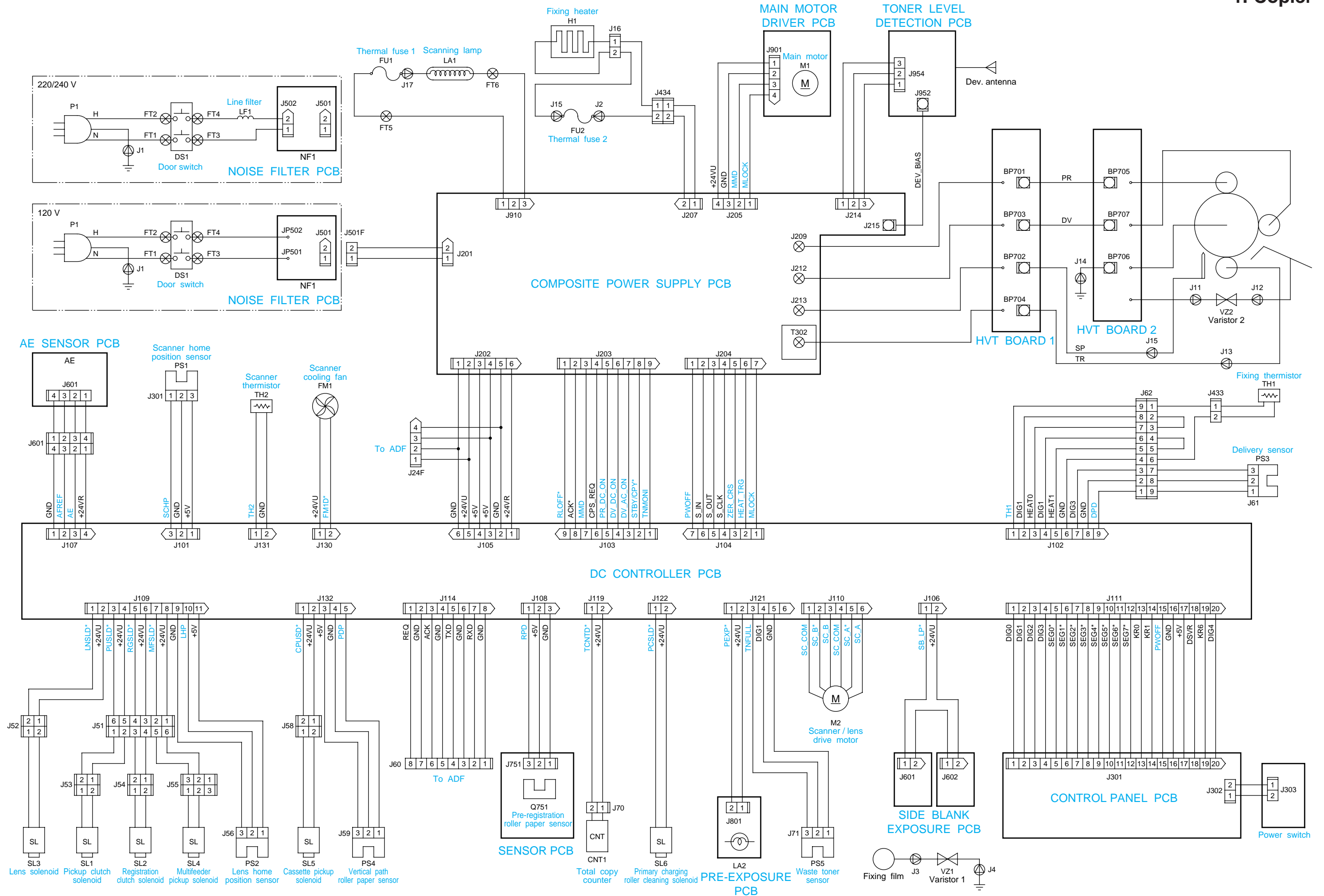

Download Service Manual And Resetter Printer at <http://printer1.blogspot.com>

## 2. ADF

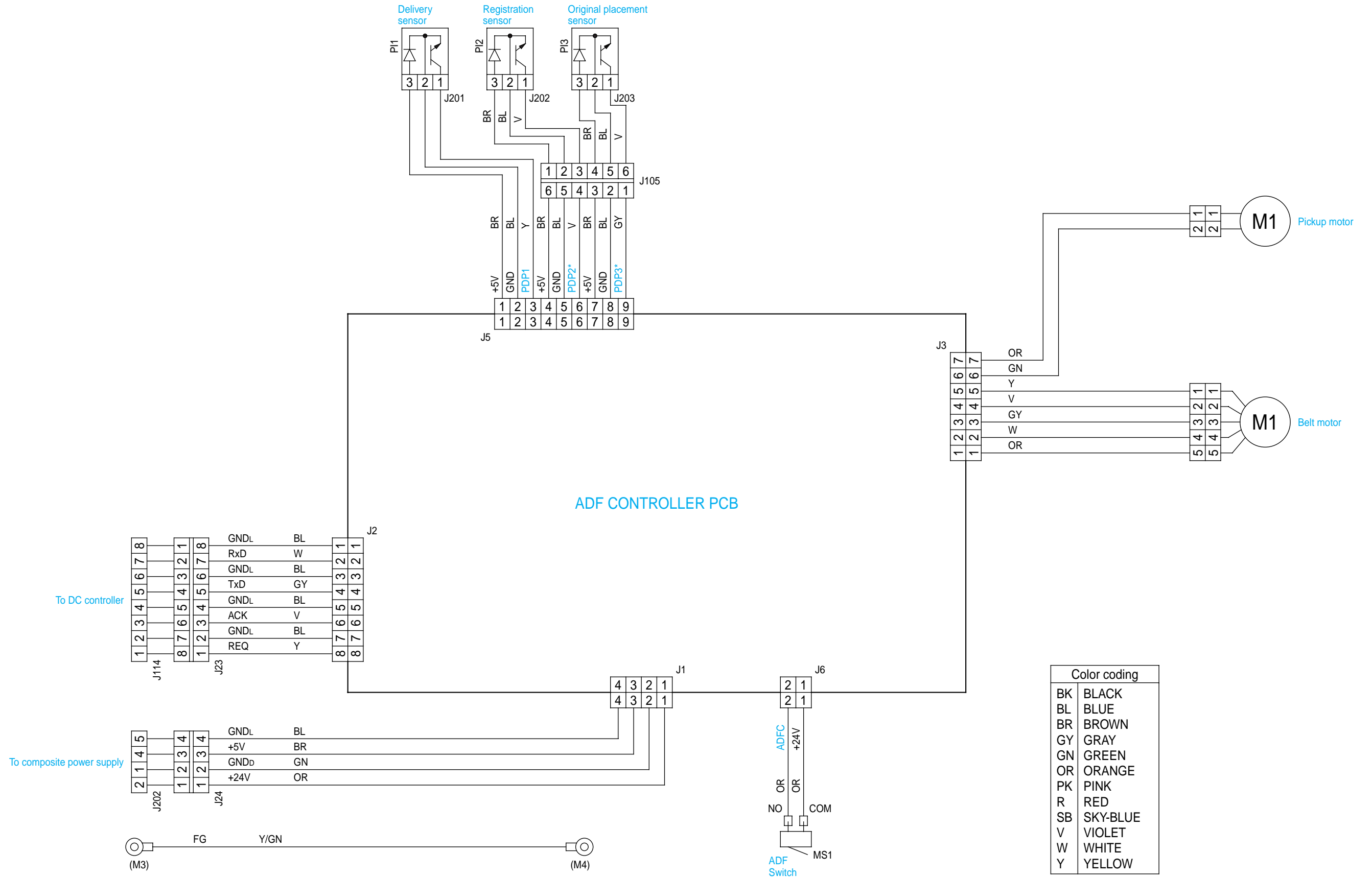

# D. DC CONTROLLER CIRCUIT DIAGRAM

## DC Controller Circuit Diagram (1/8)

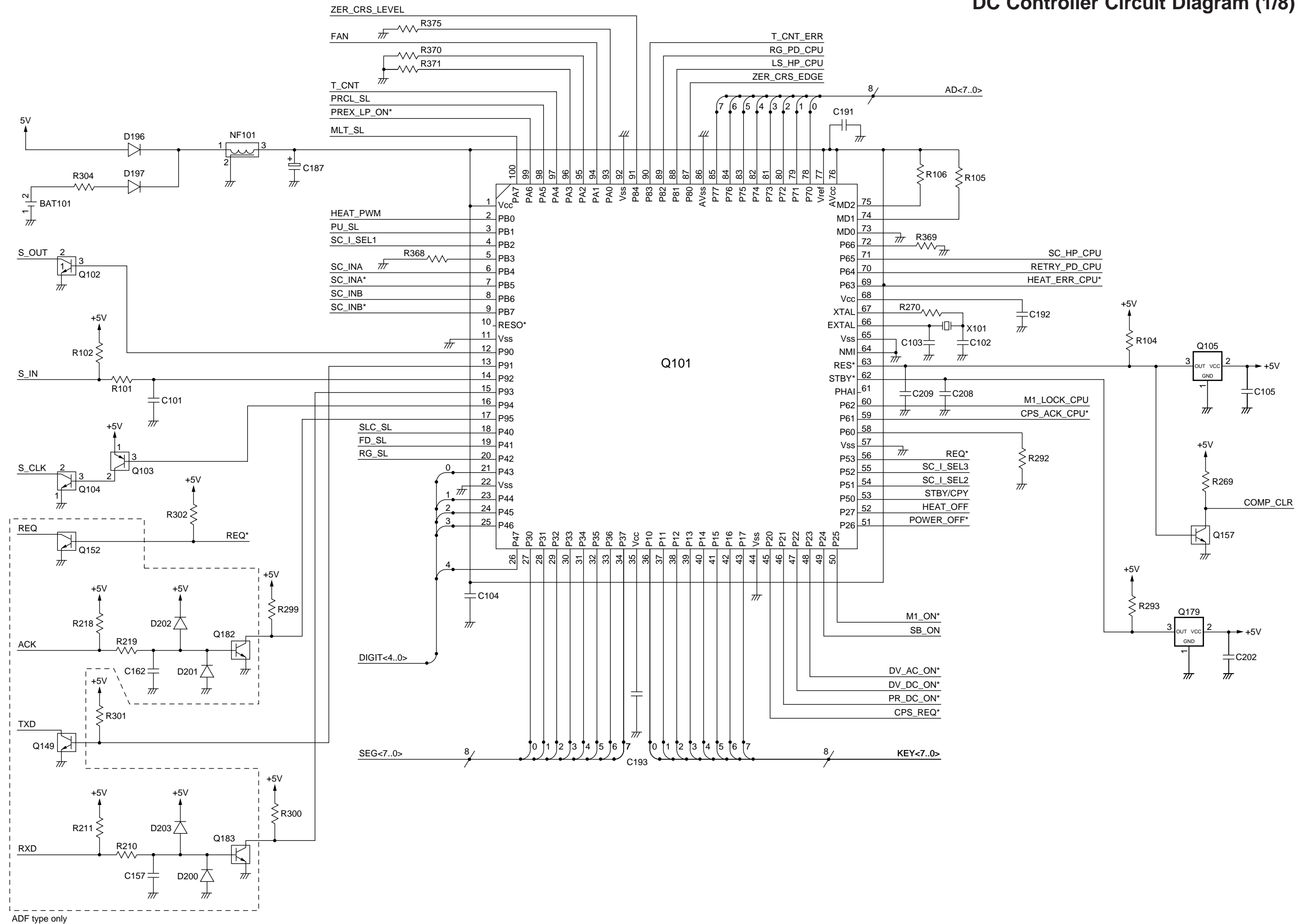

# DC Controller Circuit Diagram (2/8)

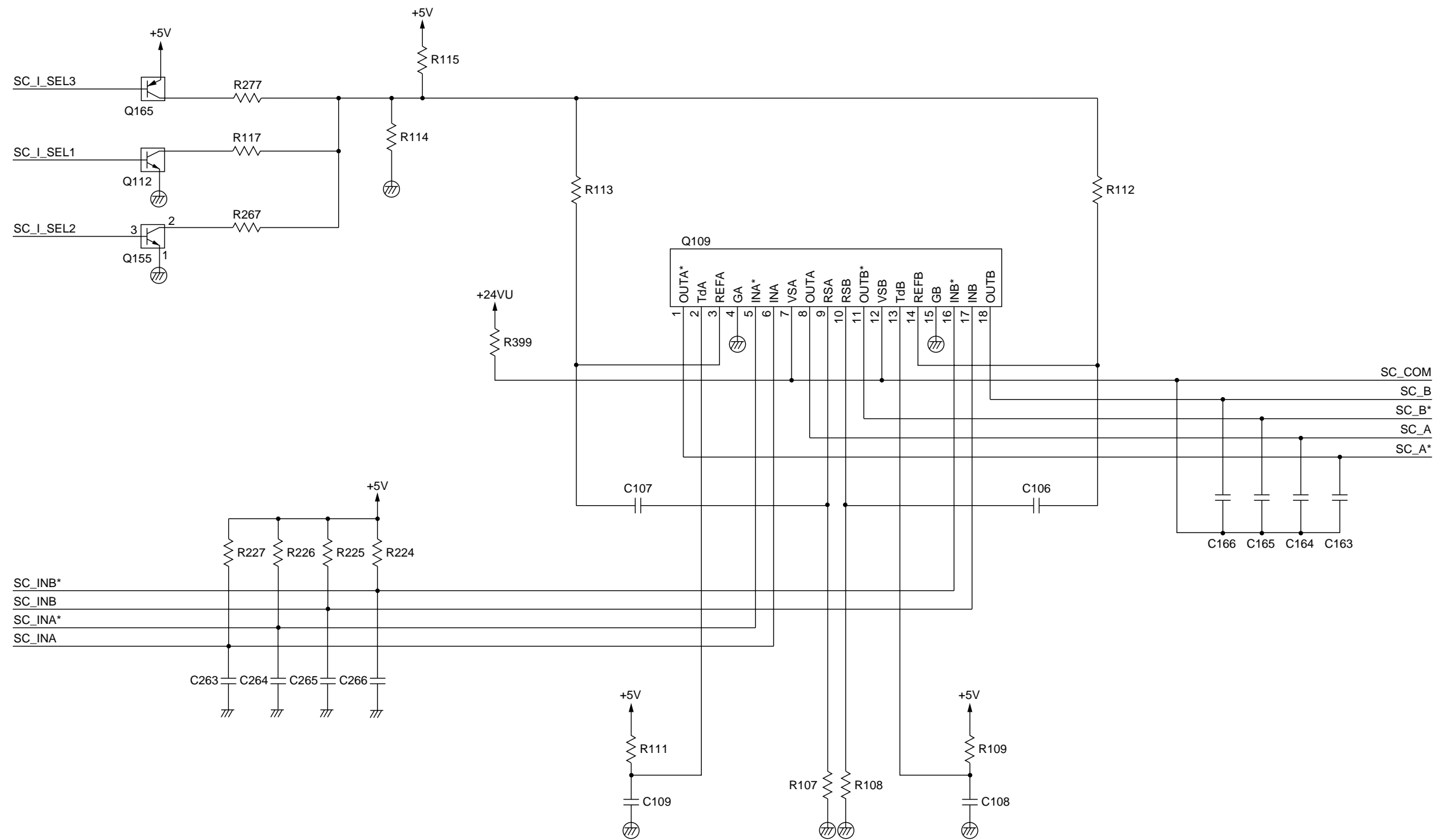



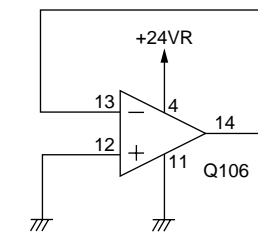
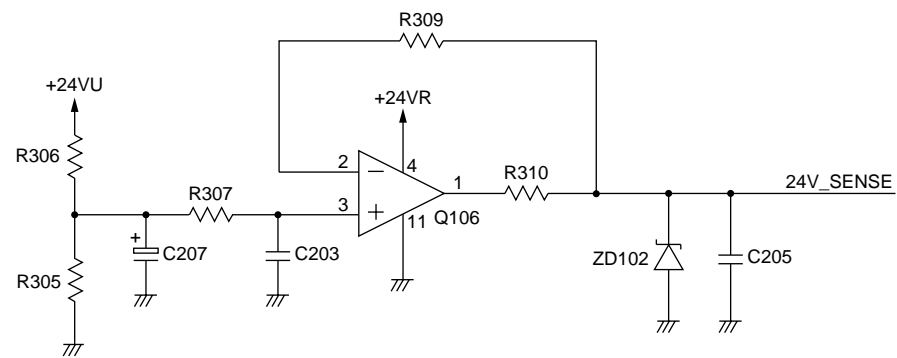
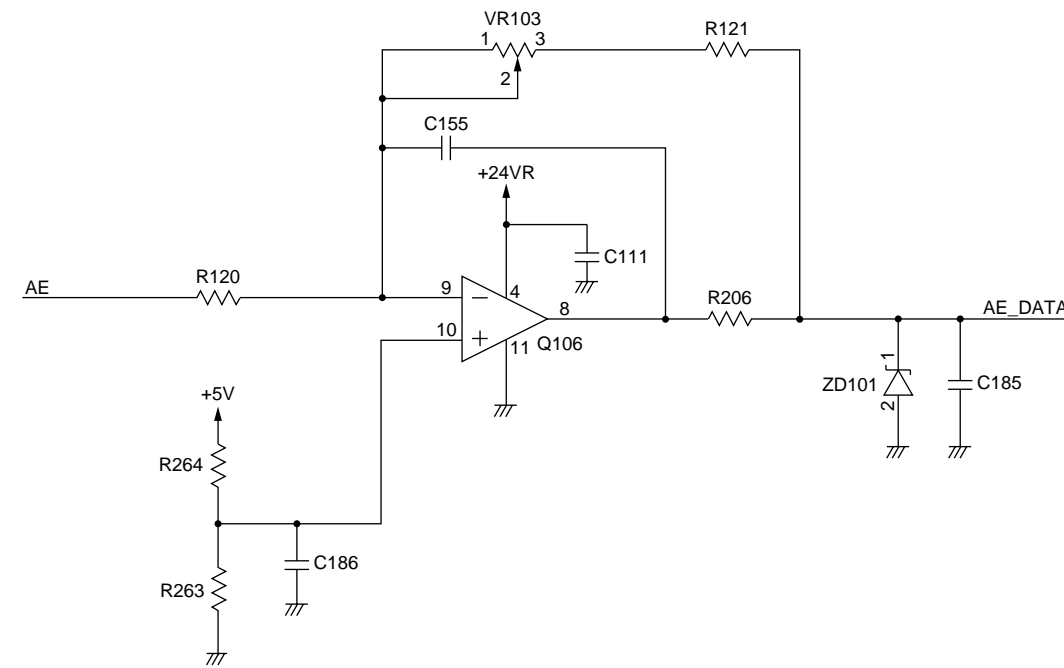
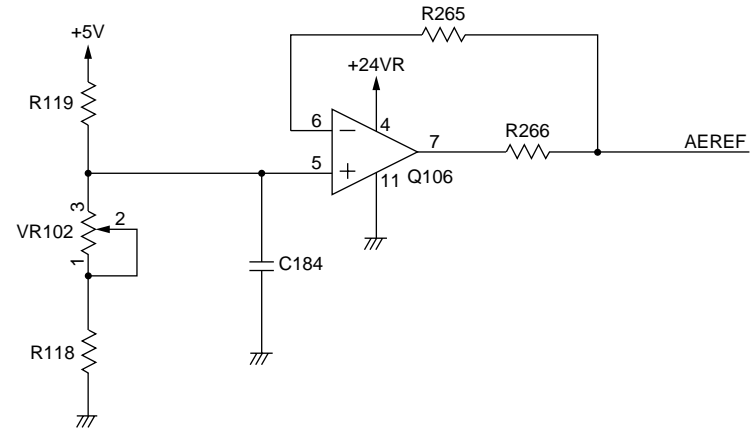

# DC Controller Circuit Diagram (4/8)

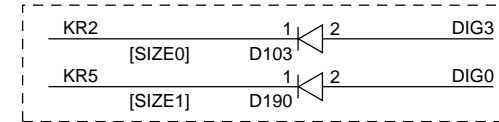
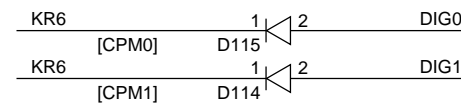
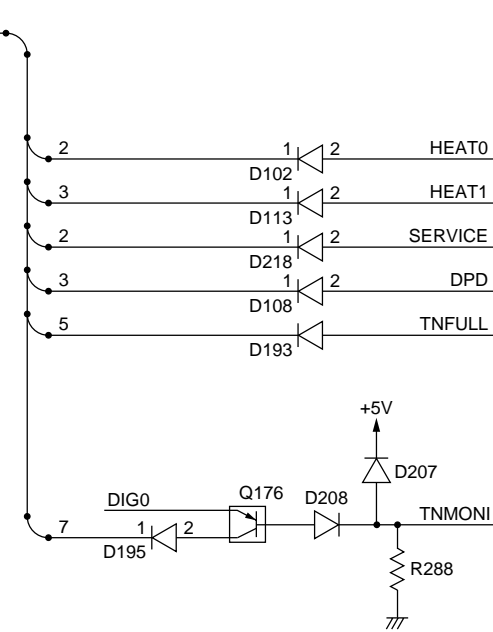
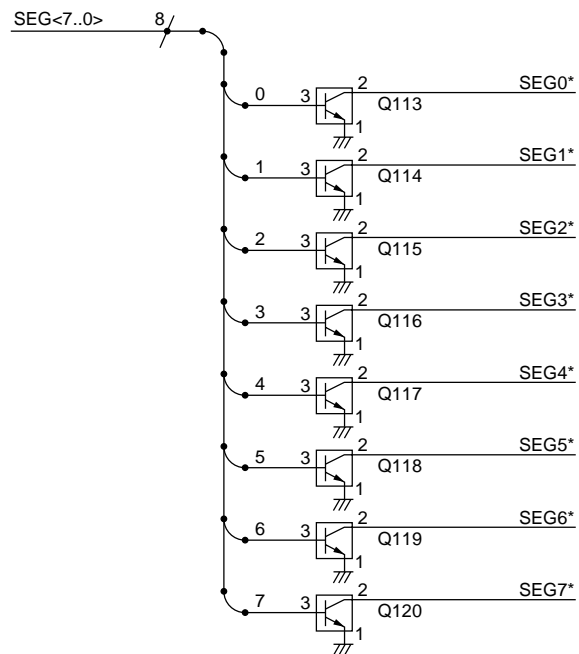
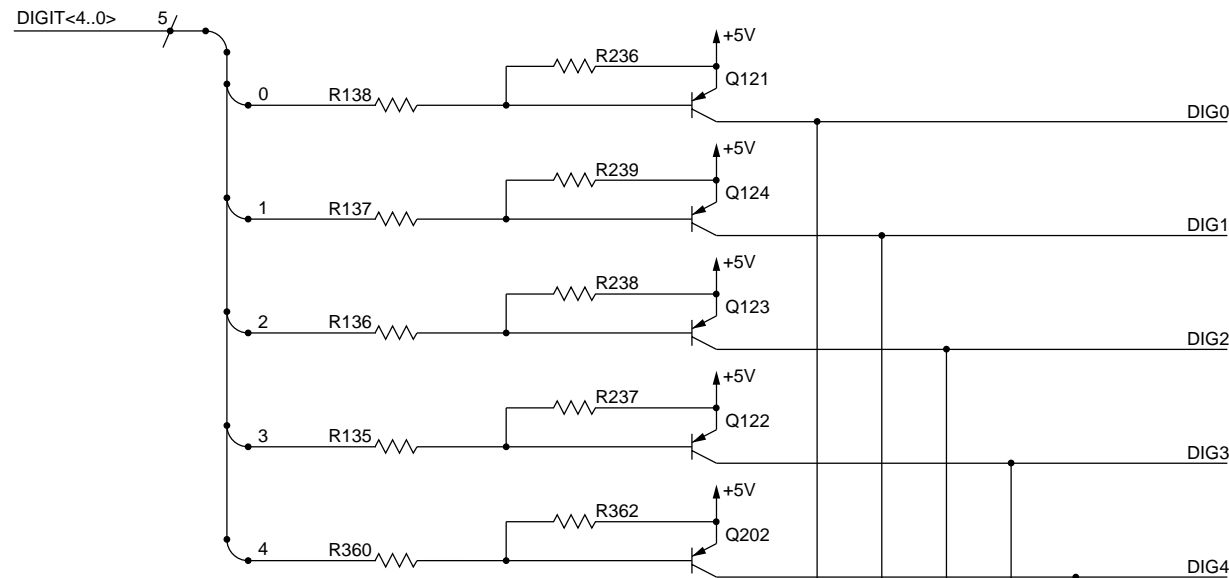
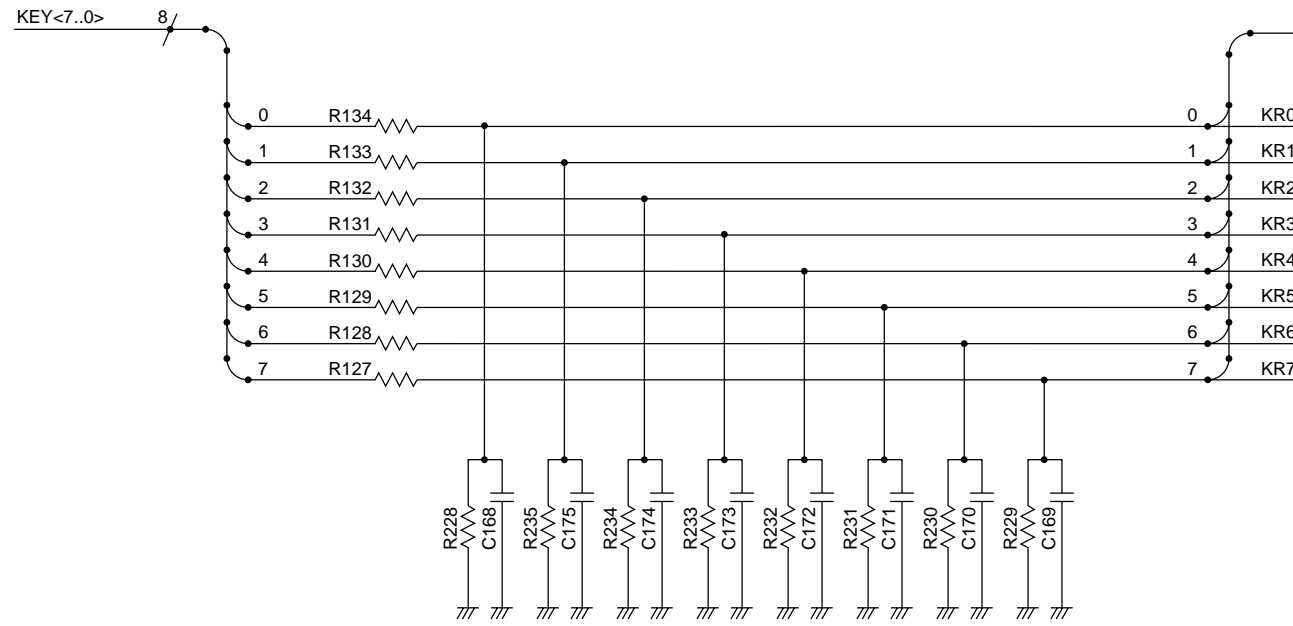

	AB/inch	inch
D103	○	×
D190	○	×

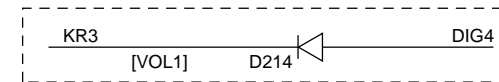

	120V	220/240V
D214	×	○

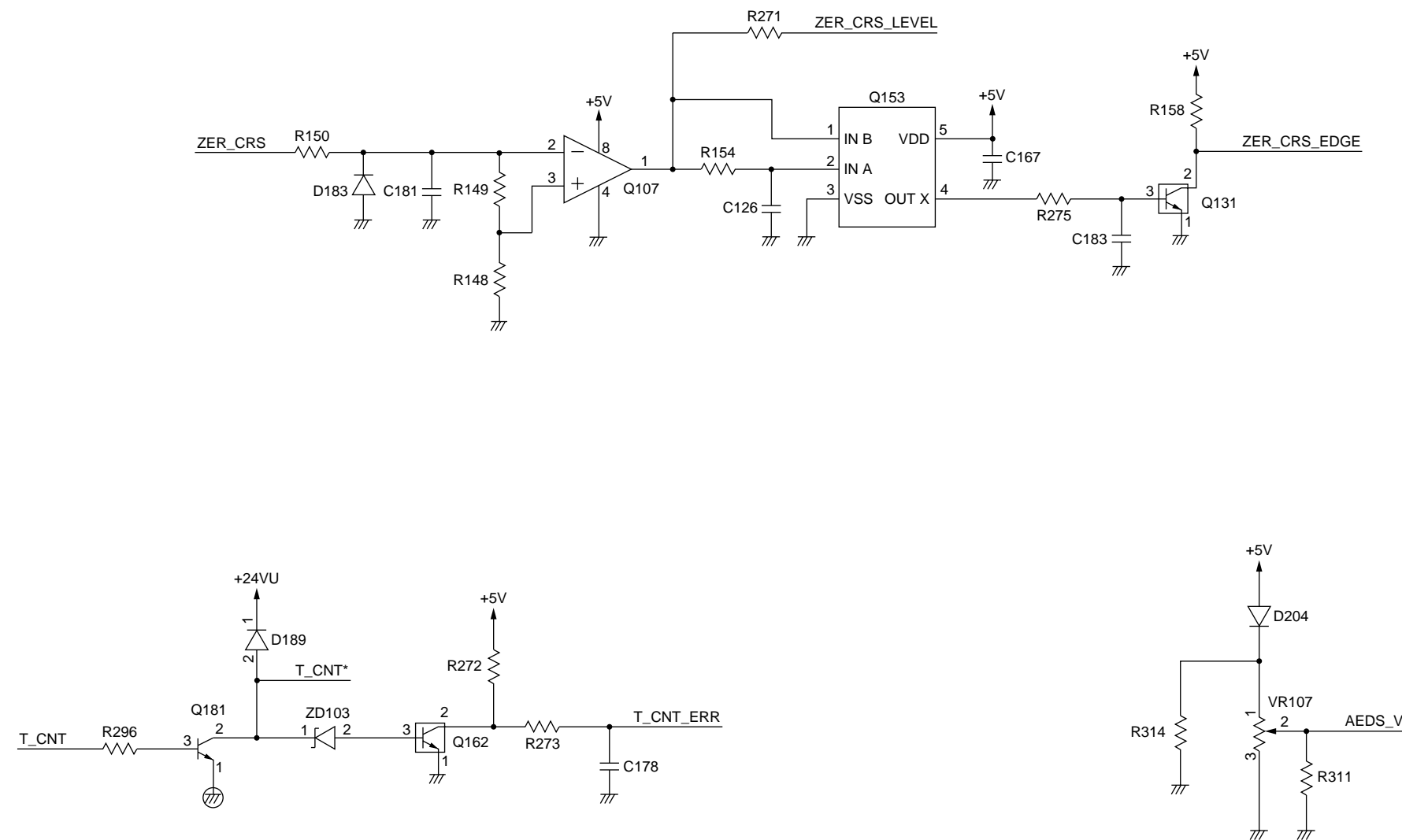

# DC Controller Circuit Diagram (6/8)

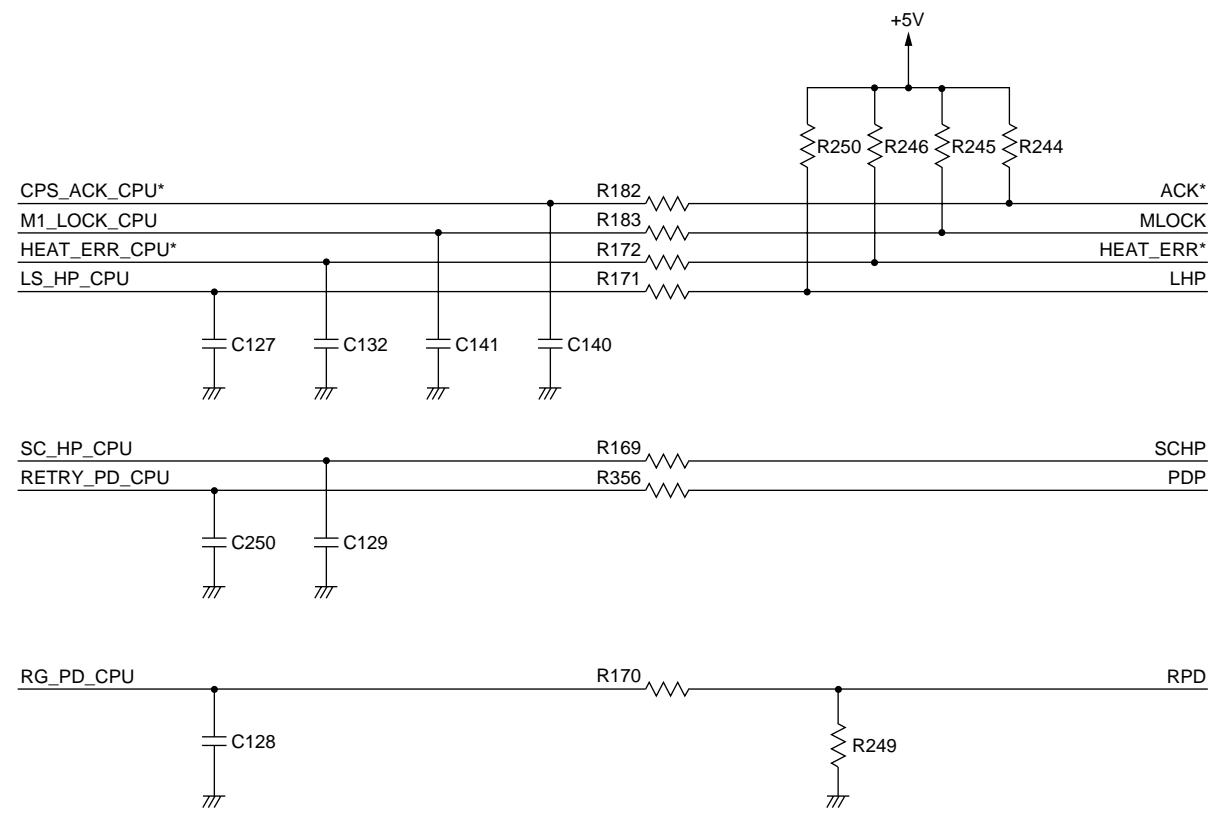
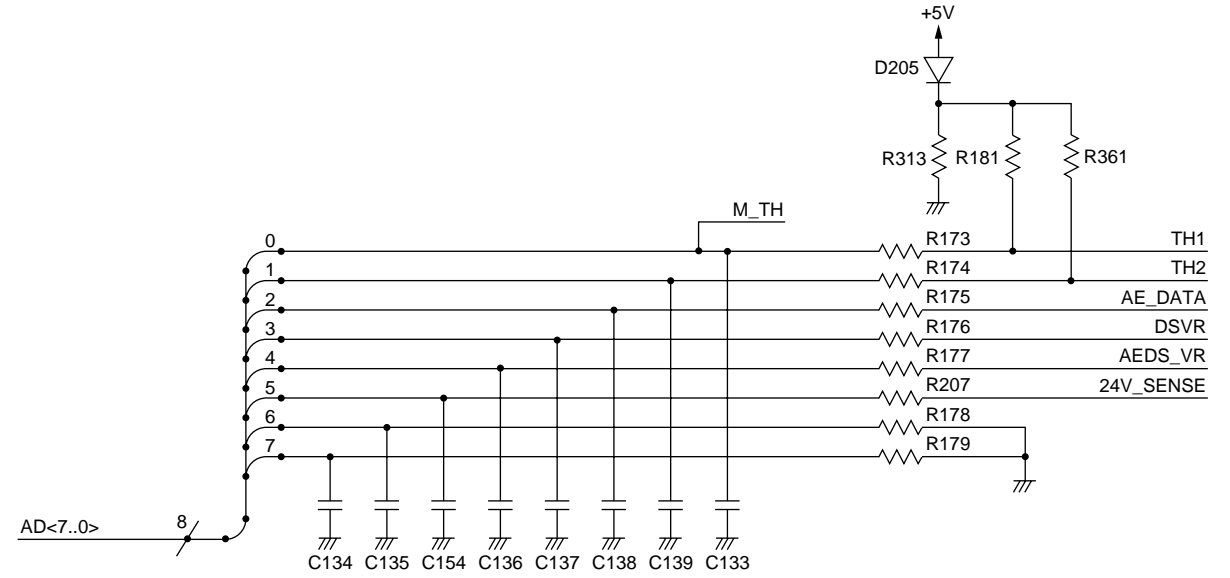
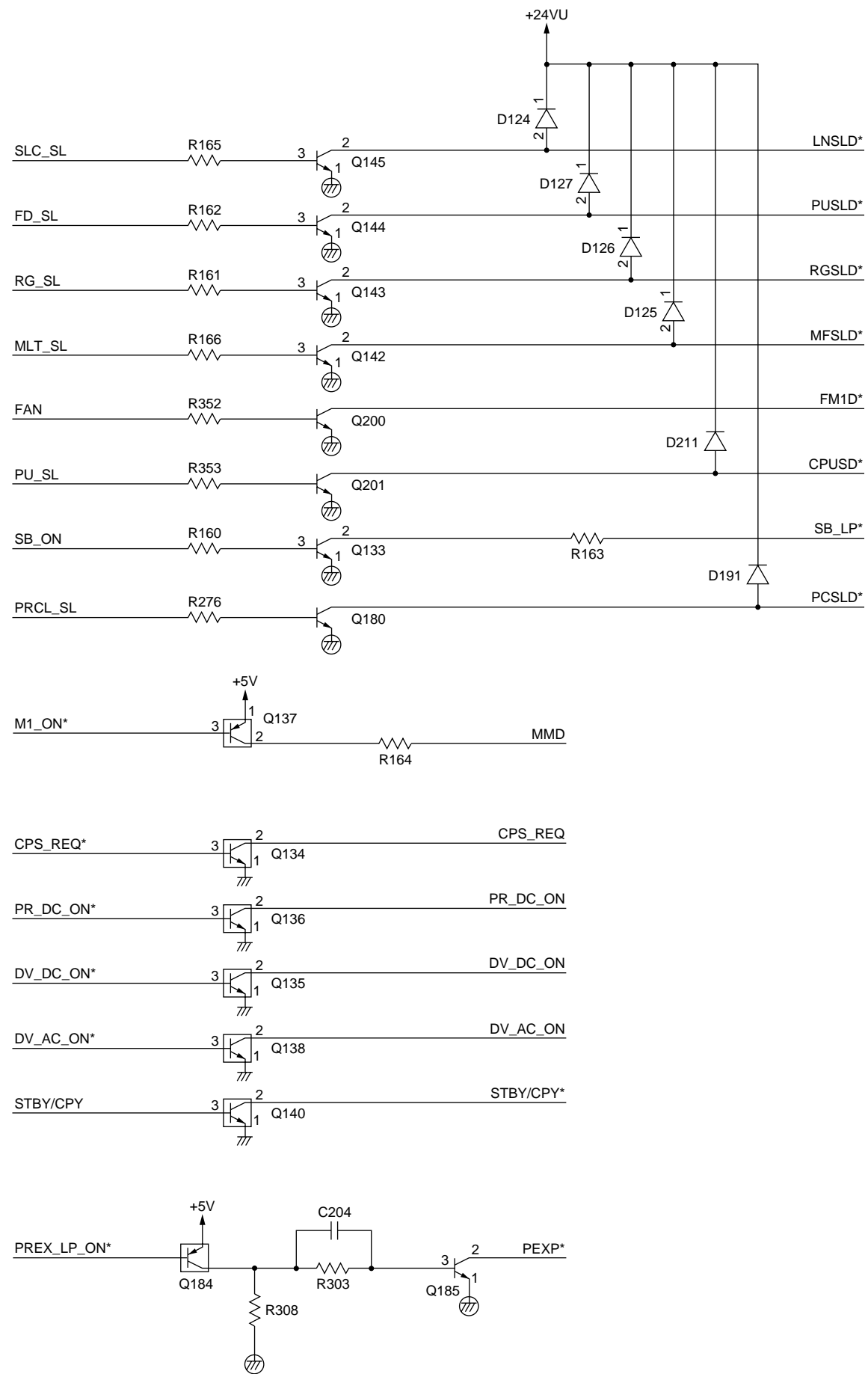

# DC Controller Circuit Diagram (7/8)

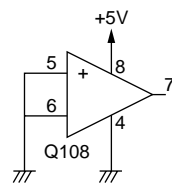
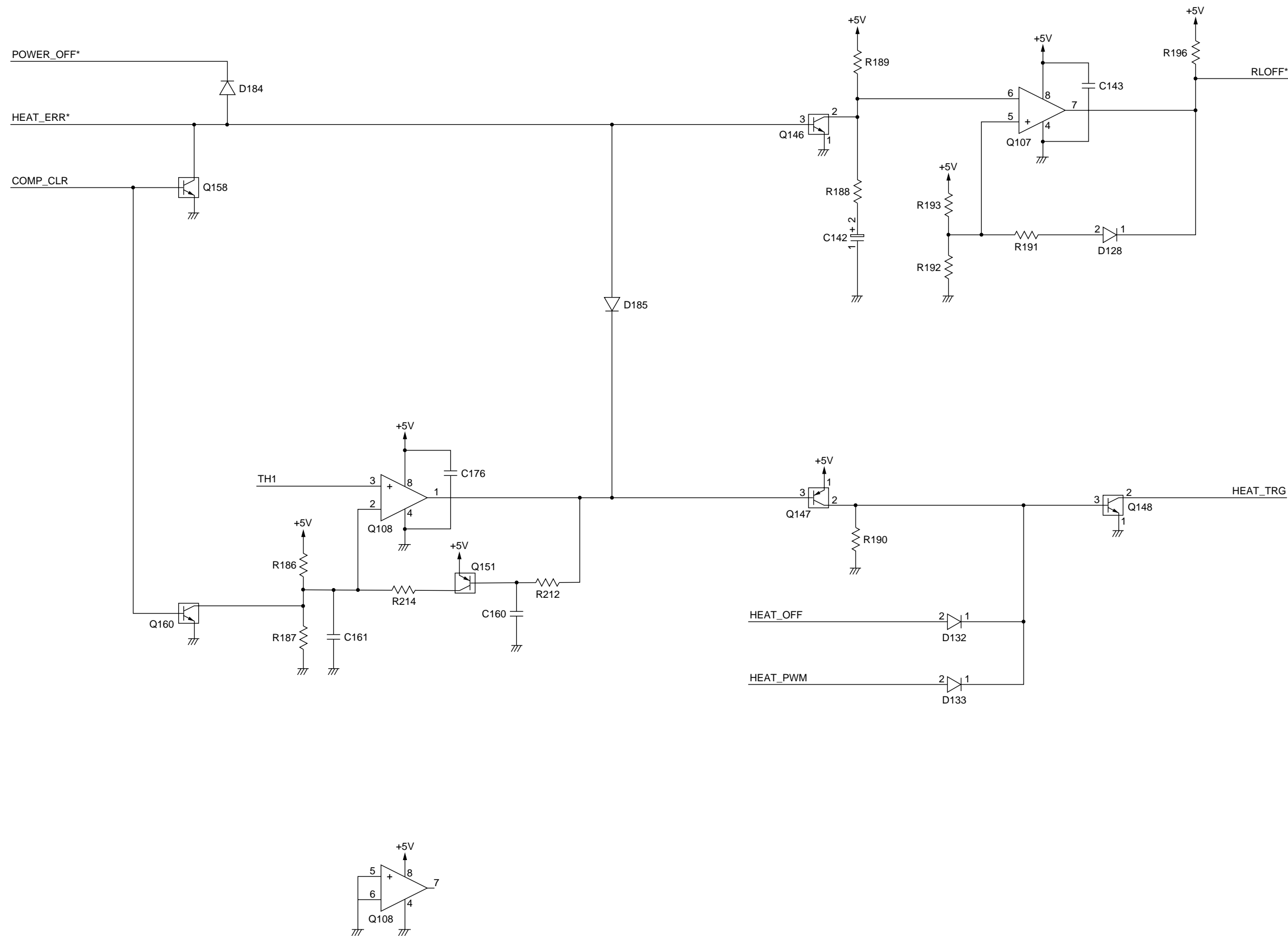

# DC Controller Circuit Diagram (8/8)

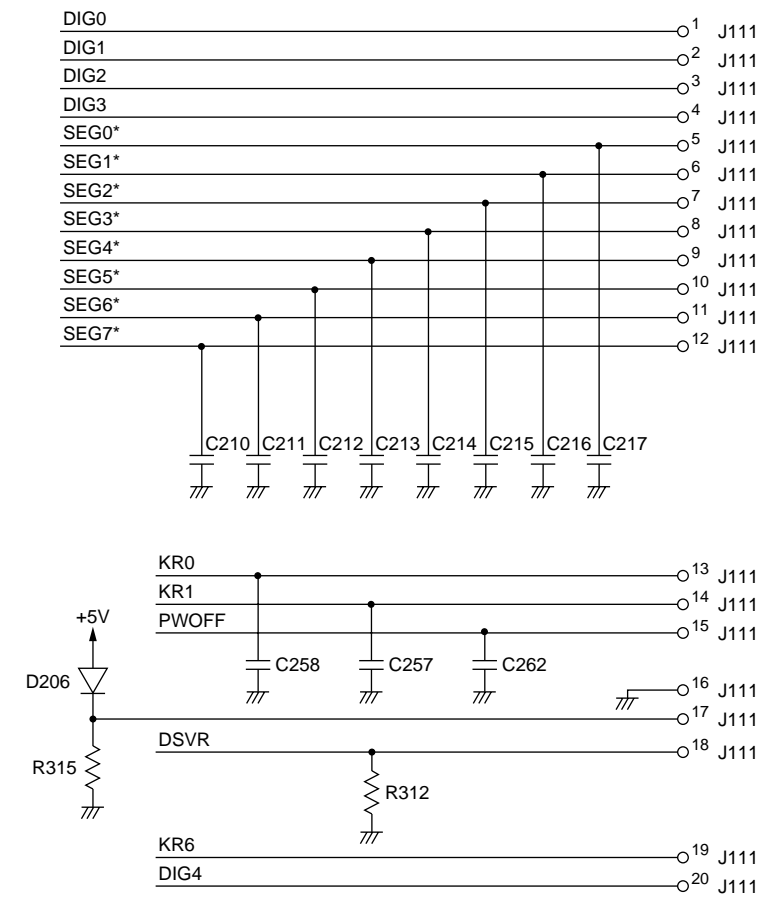
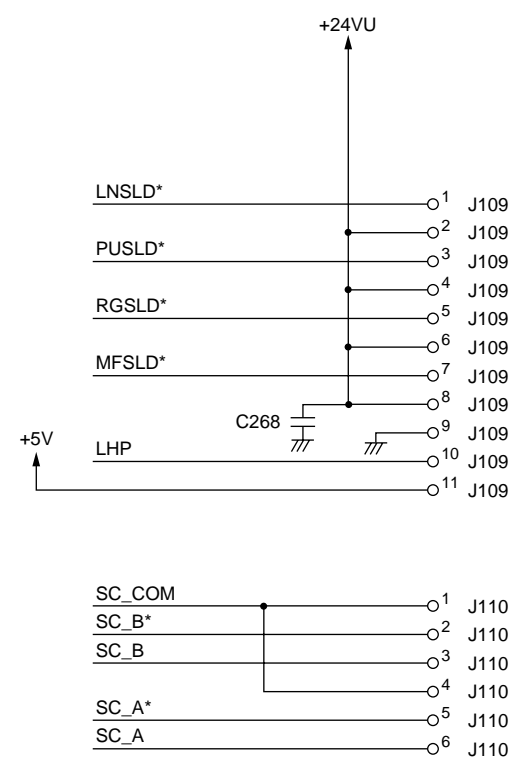
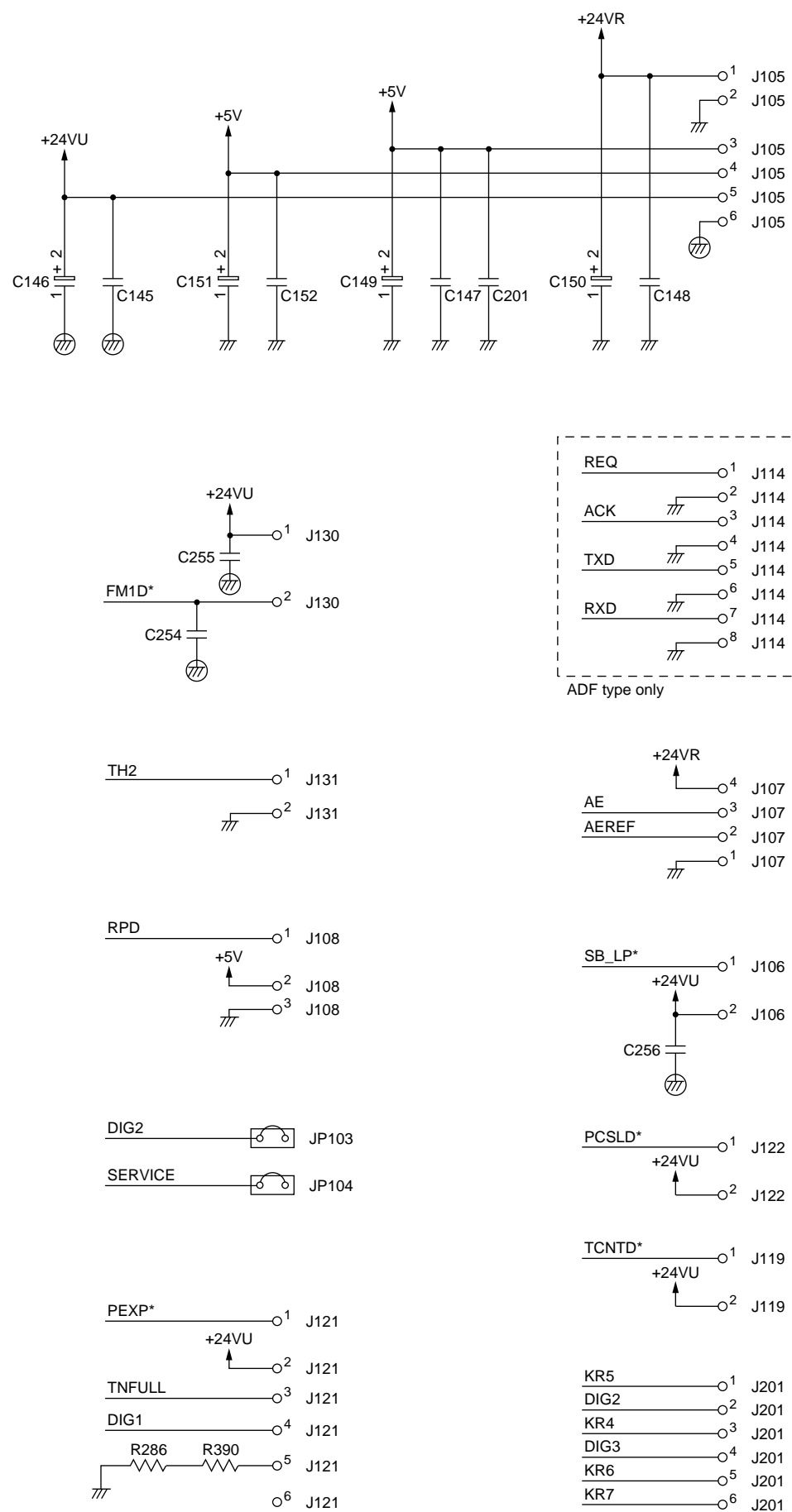
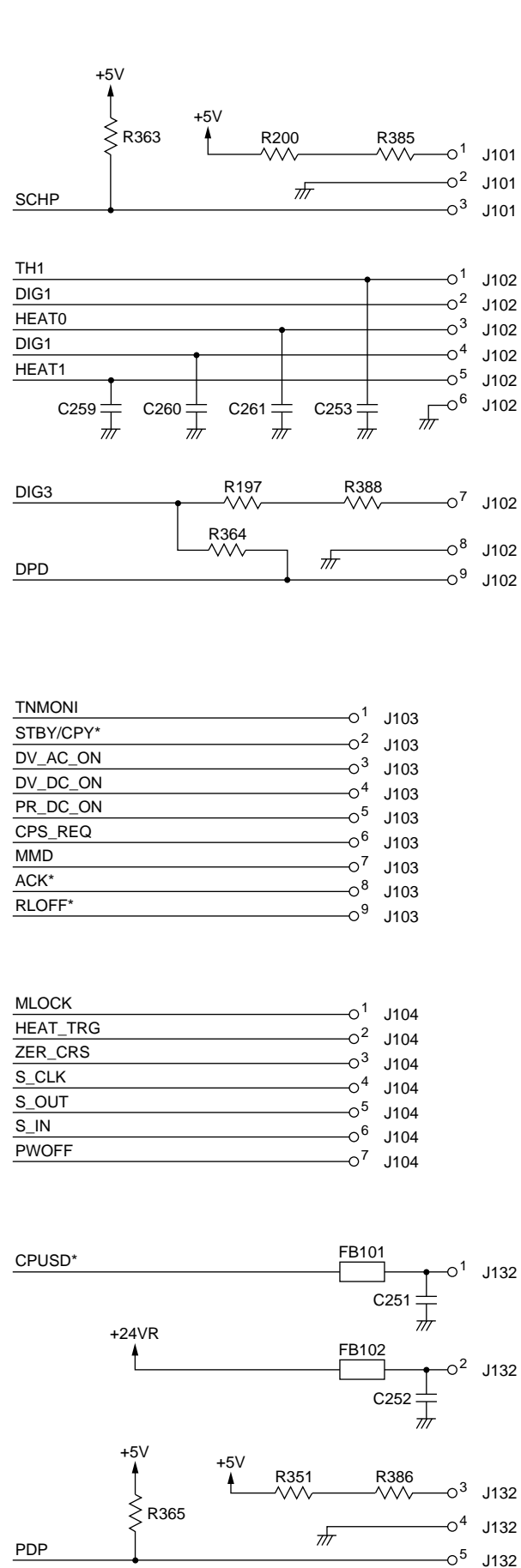

# E. ADF CONTROLLER CIRCUIT DIAGRAM

## ADF Controller Circuit Diagram (1/3)

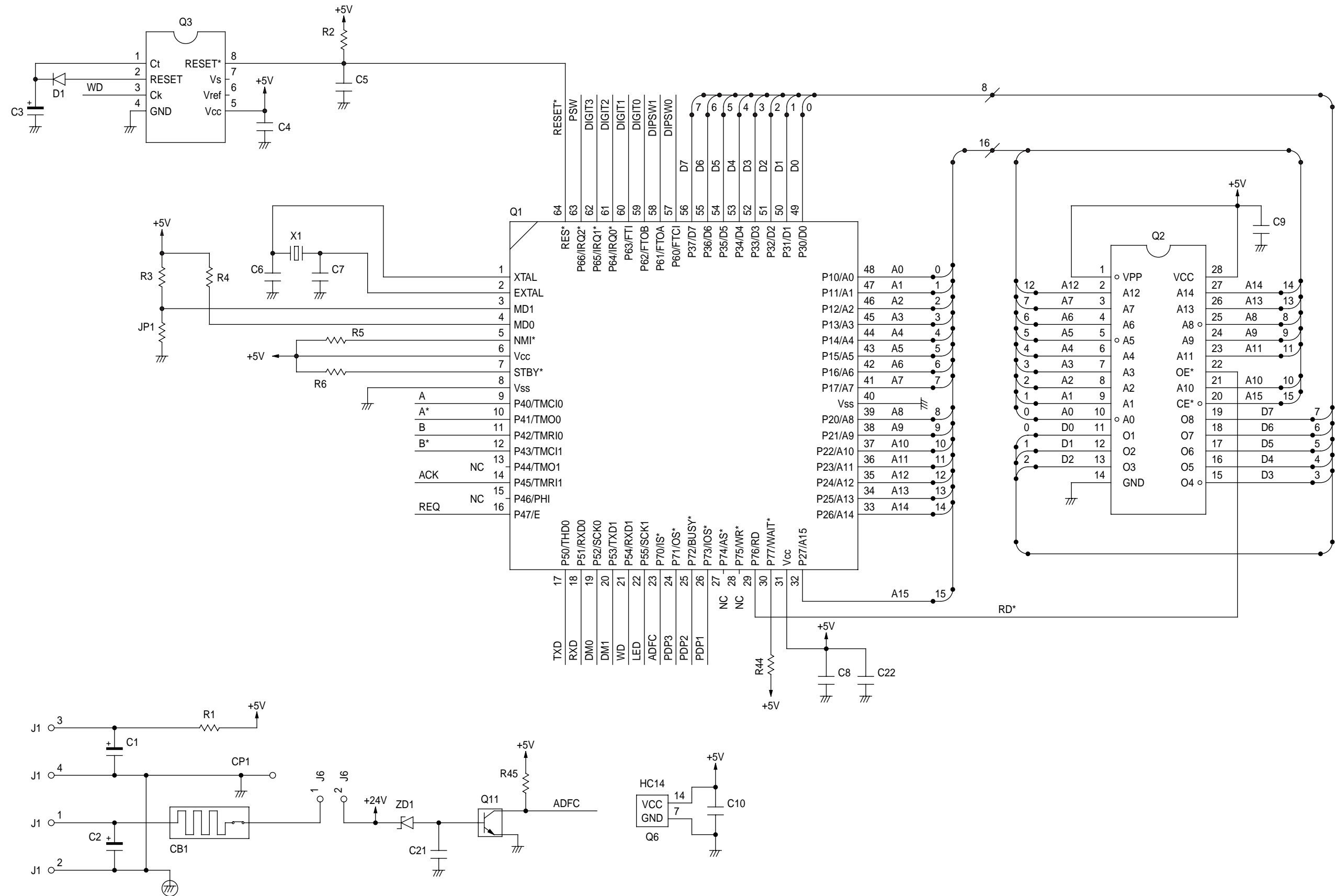

# ADF Controller Circuit Diagram (2/3)

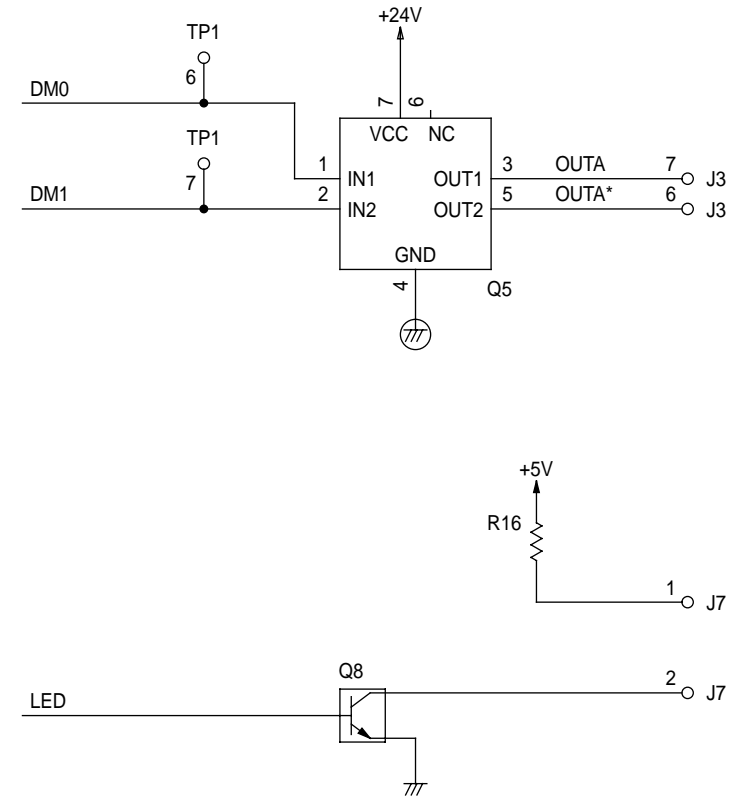
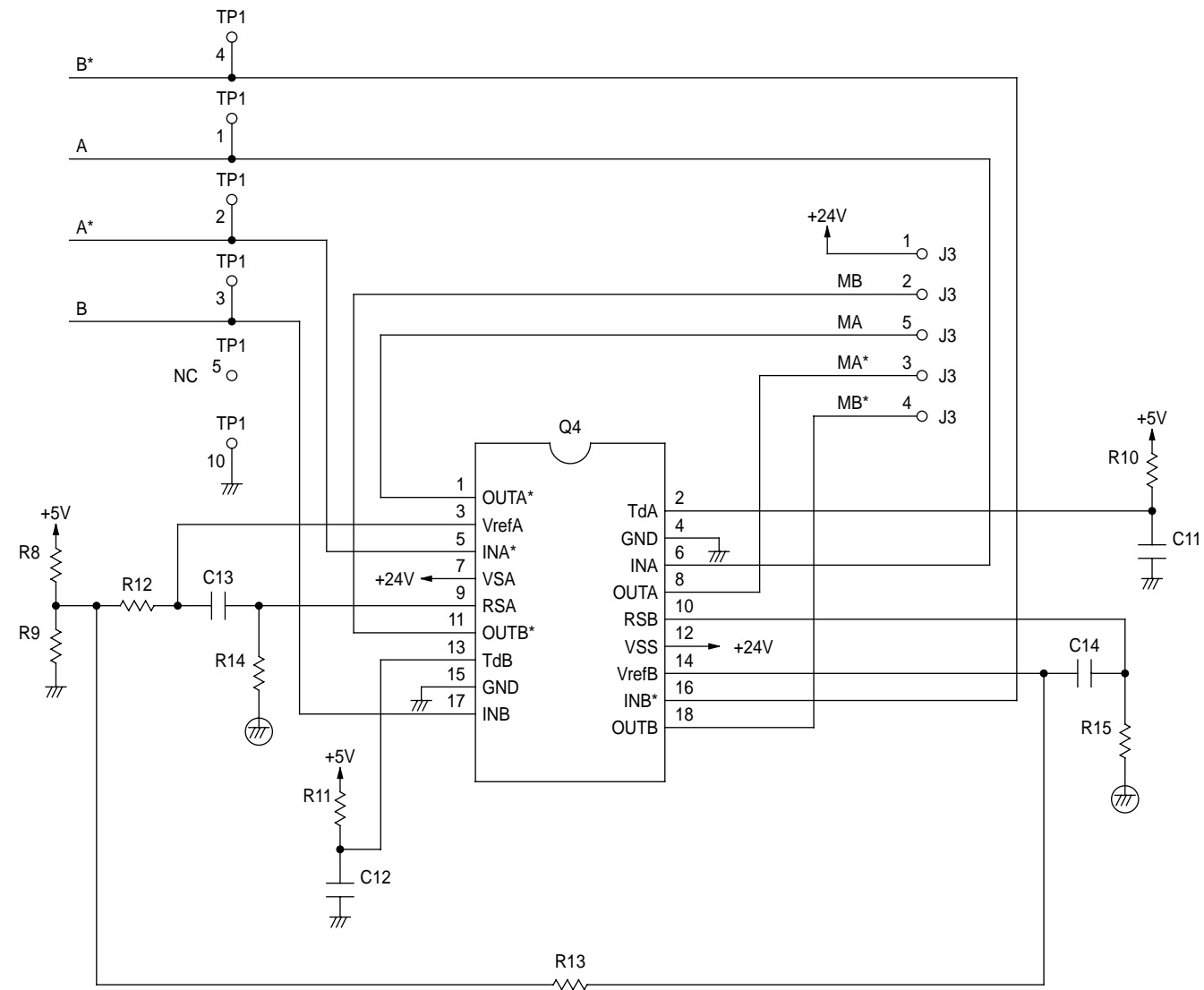



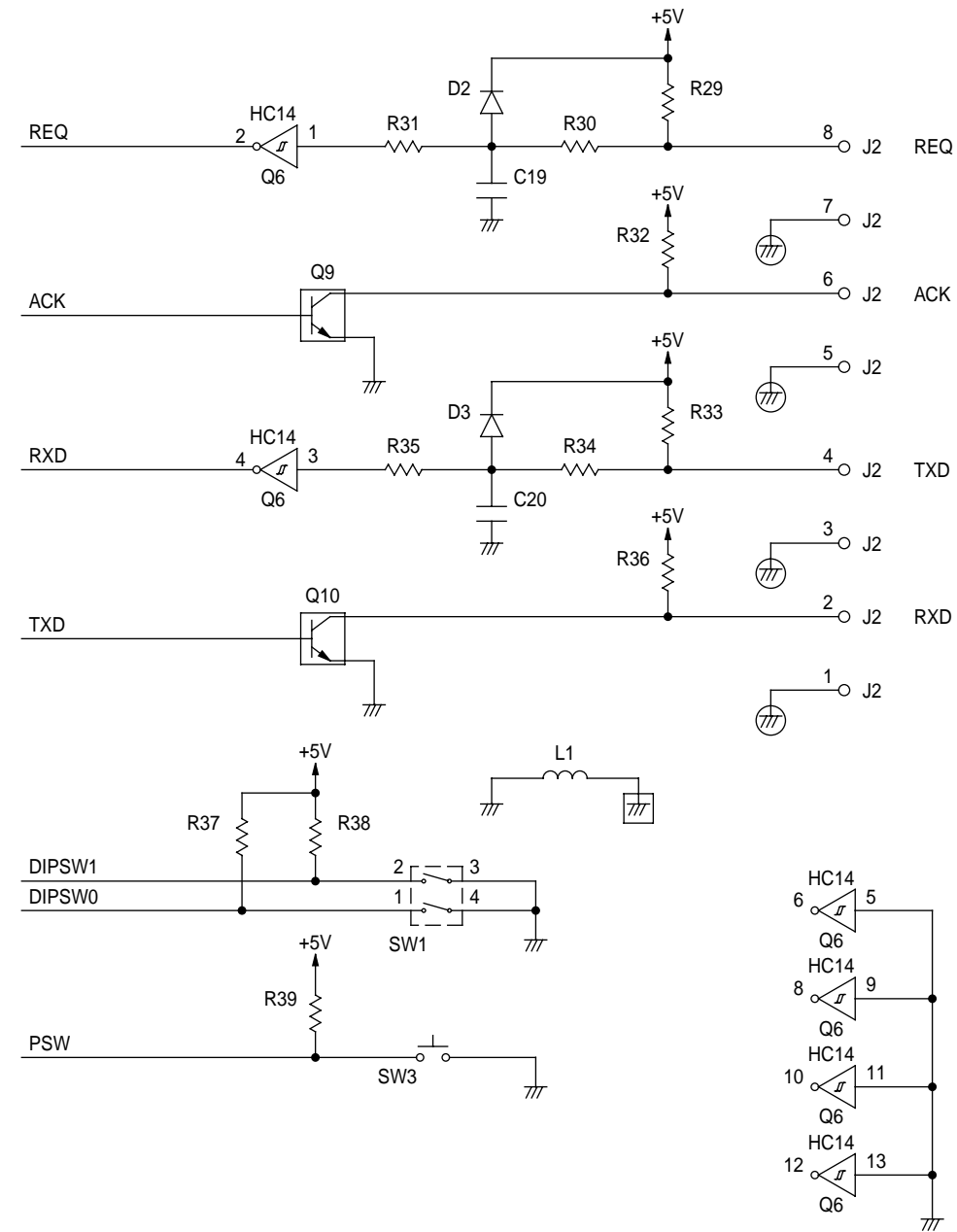
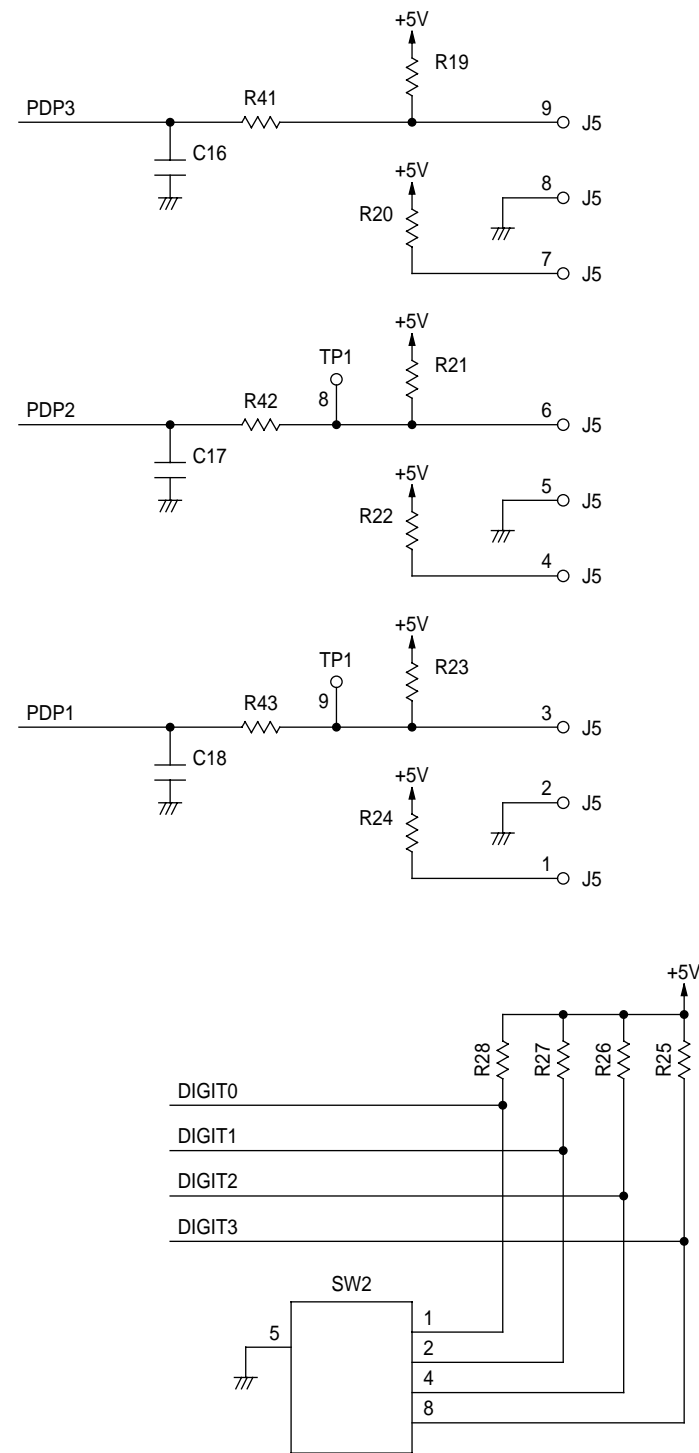



# F. COMPOSITE POWER SUPPLY CIRCUIT DIAGRAM

Composite Power Supply Circuit Diagram (1/9)

[A502]

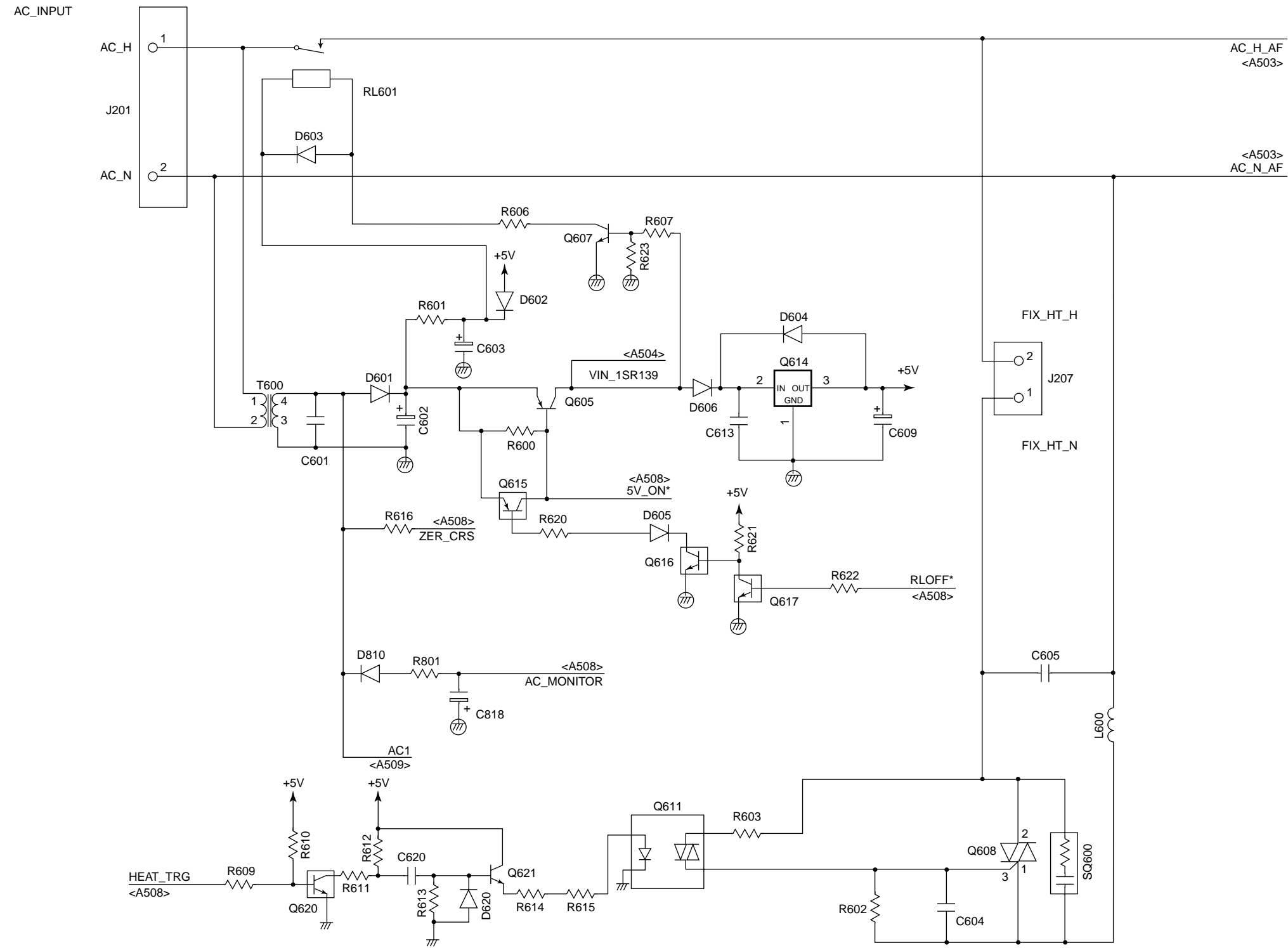

# Composite Power Supply Circuit Diagram (2/9) [A503]

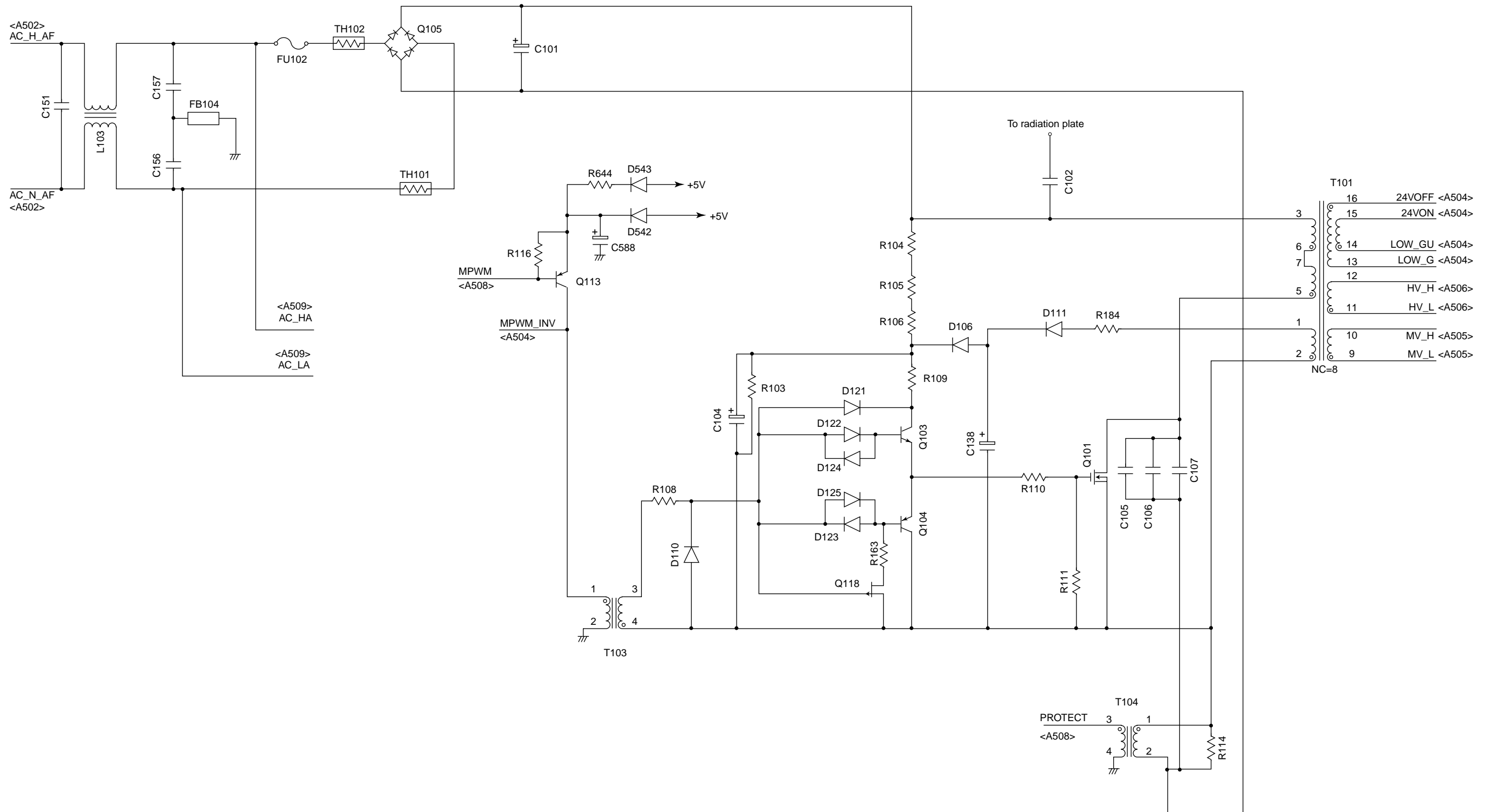

# Composite Power Supply Circuit Diagram (3/9) [A504]

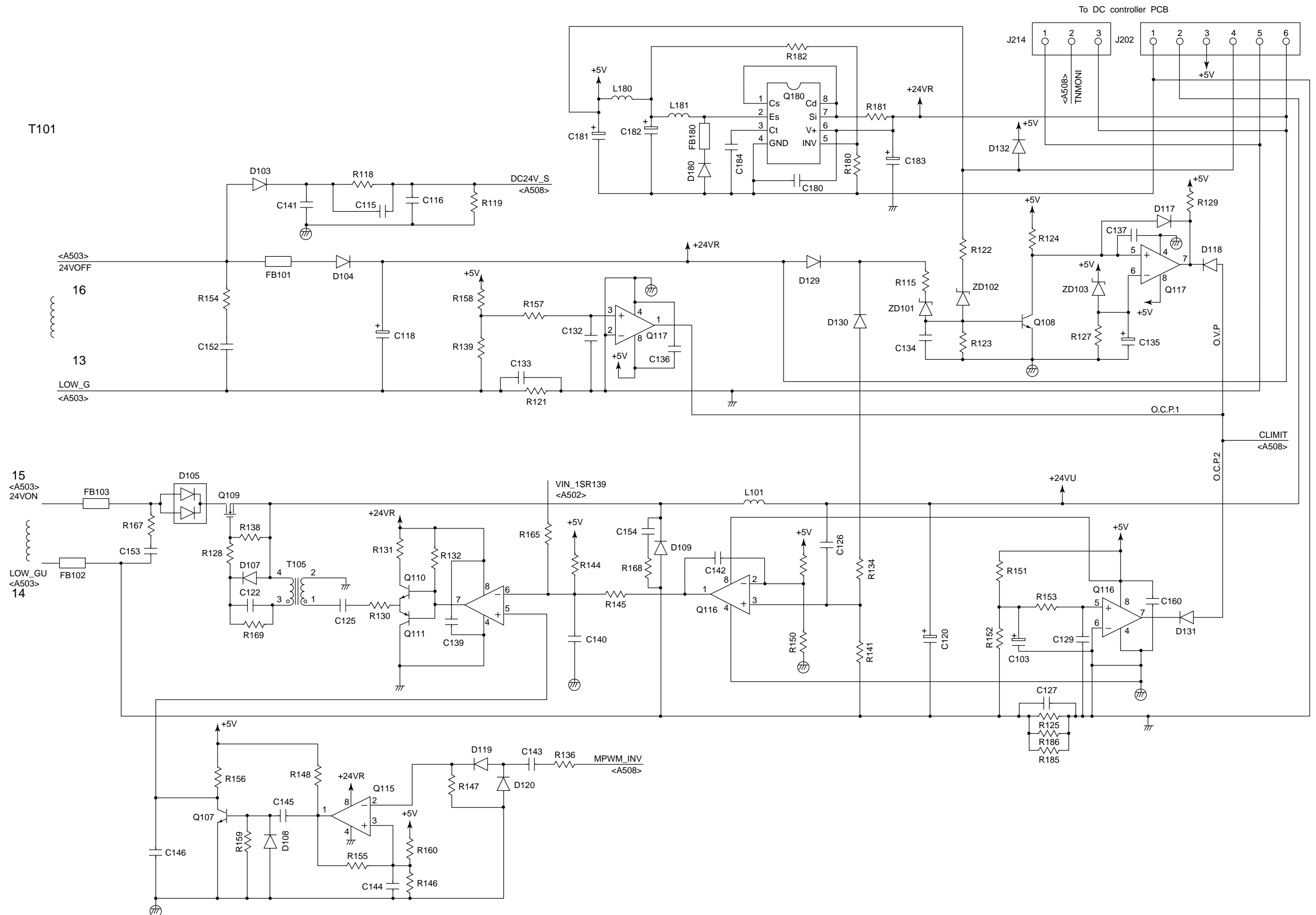

Download Service Manual And Resetter Printer at <http://printer1.blogspot.com>

Composite Power Supply Circuit Diagram (4/9)  
[A505]

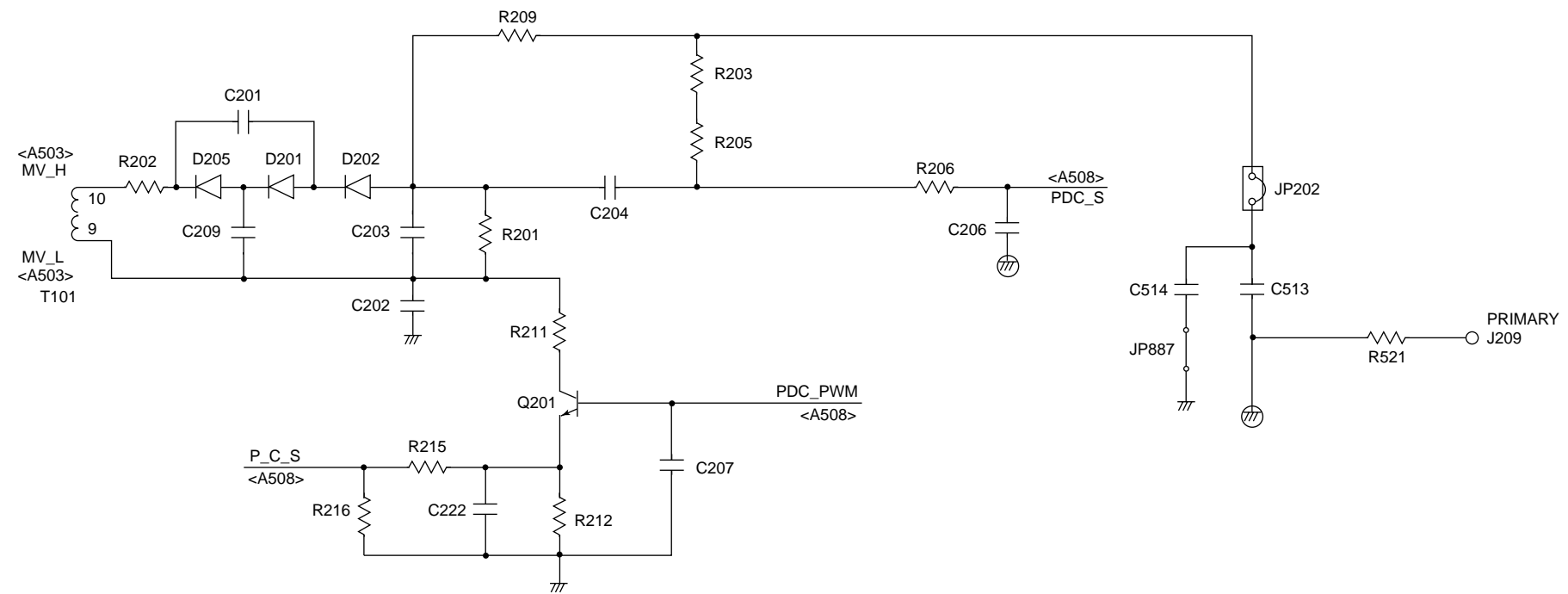

# Composite Power Supply Circuit Diagram (5/9) [A506]

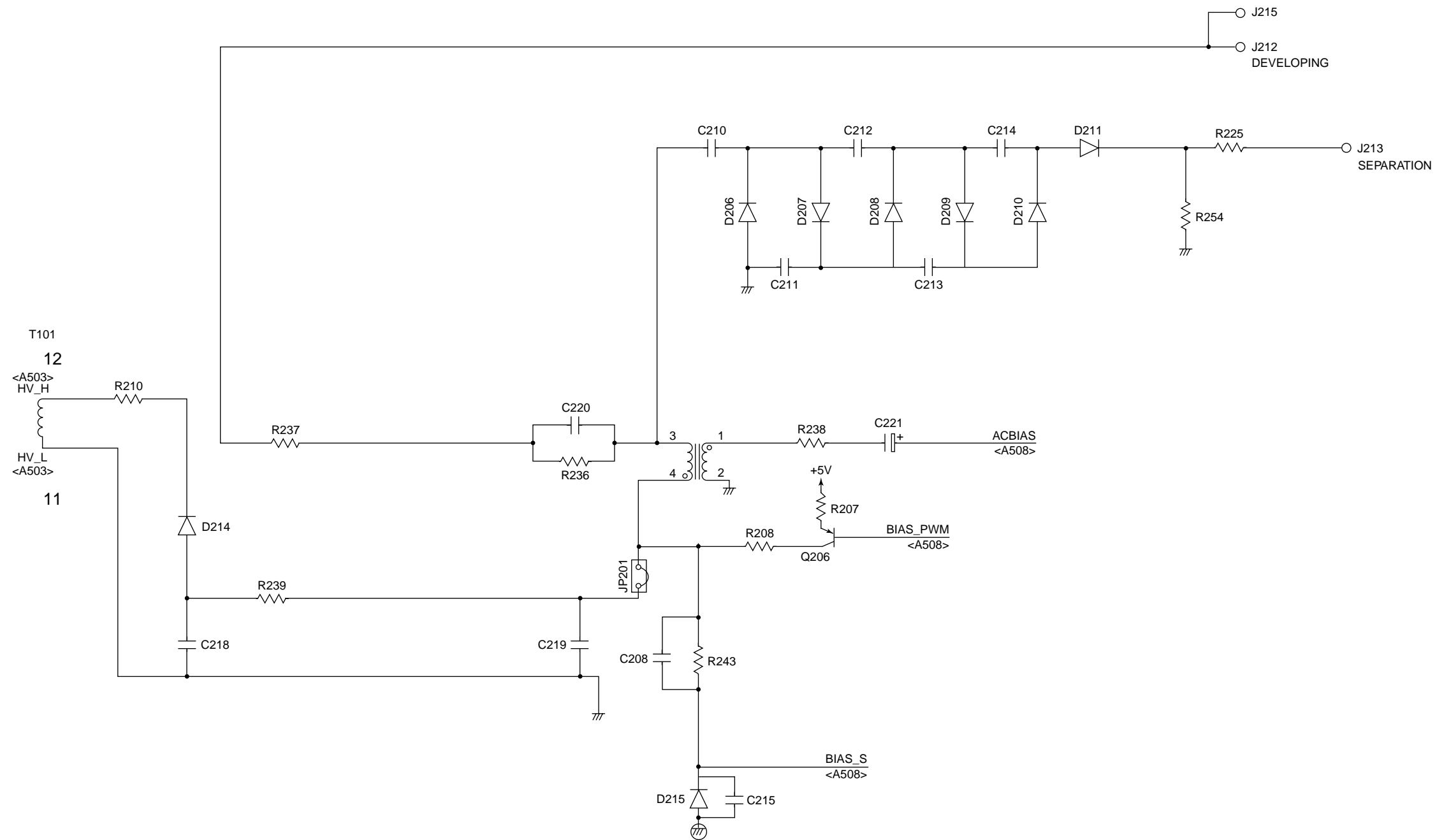

Composite Power Supply Circuit Diagram (6/9)  
[A507]

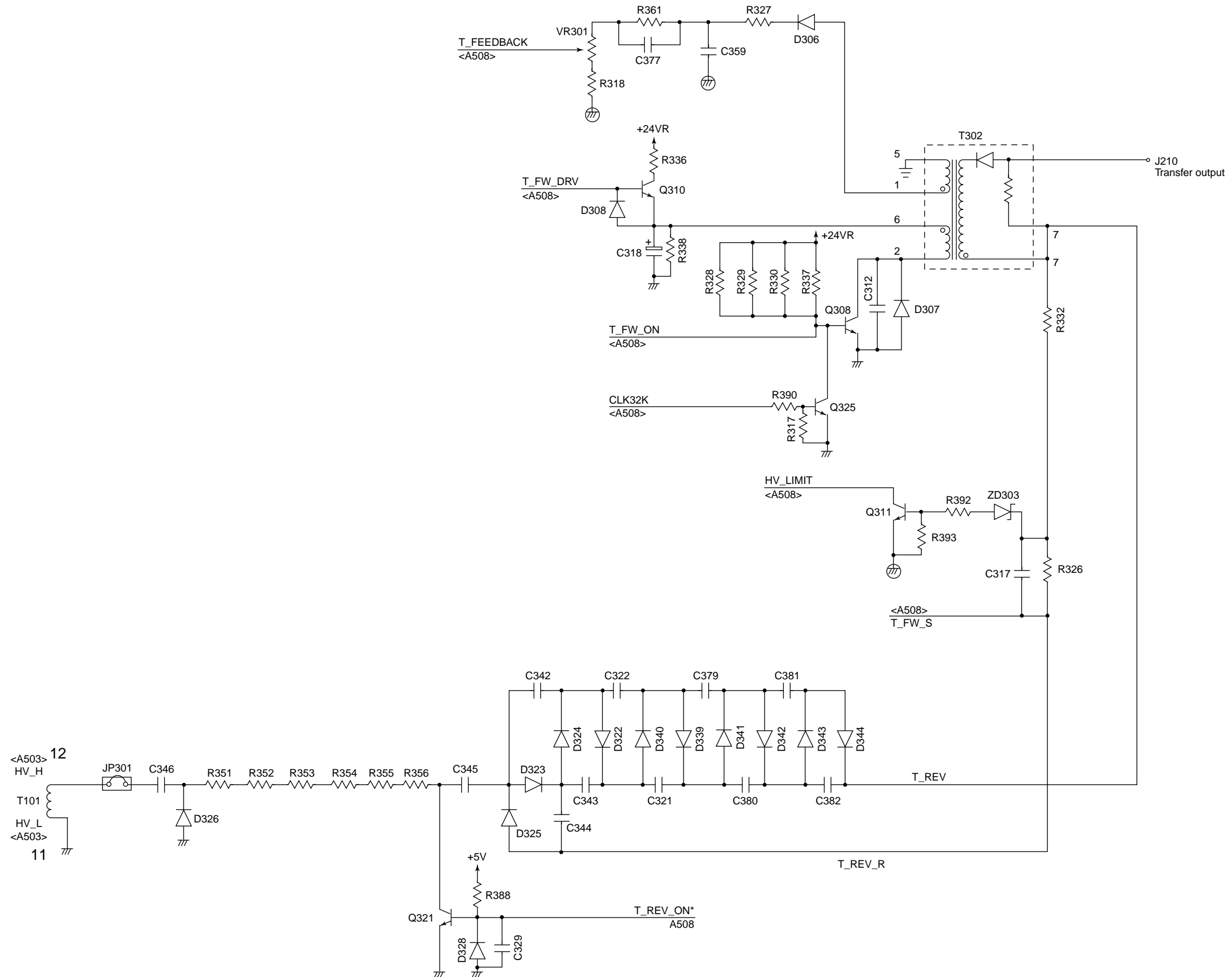



# Composite Power Supply Circuit Diagram (7/9) [A508]

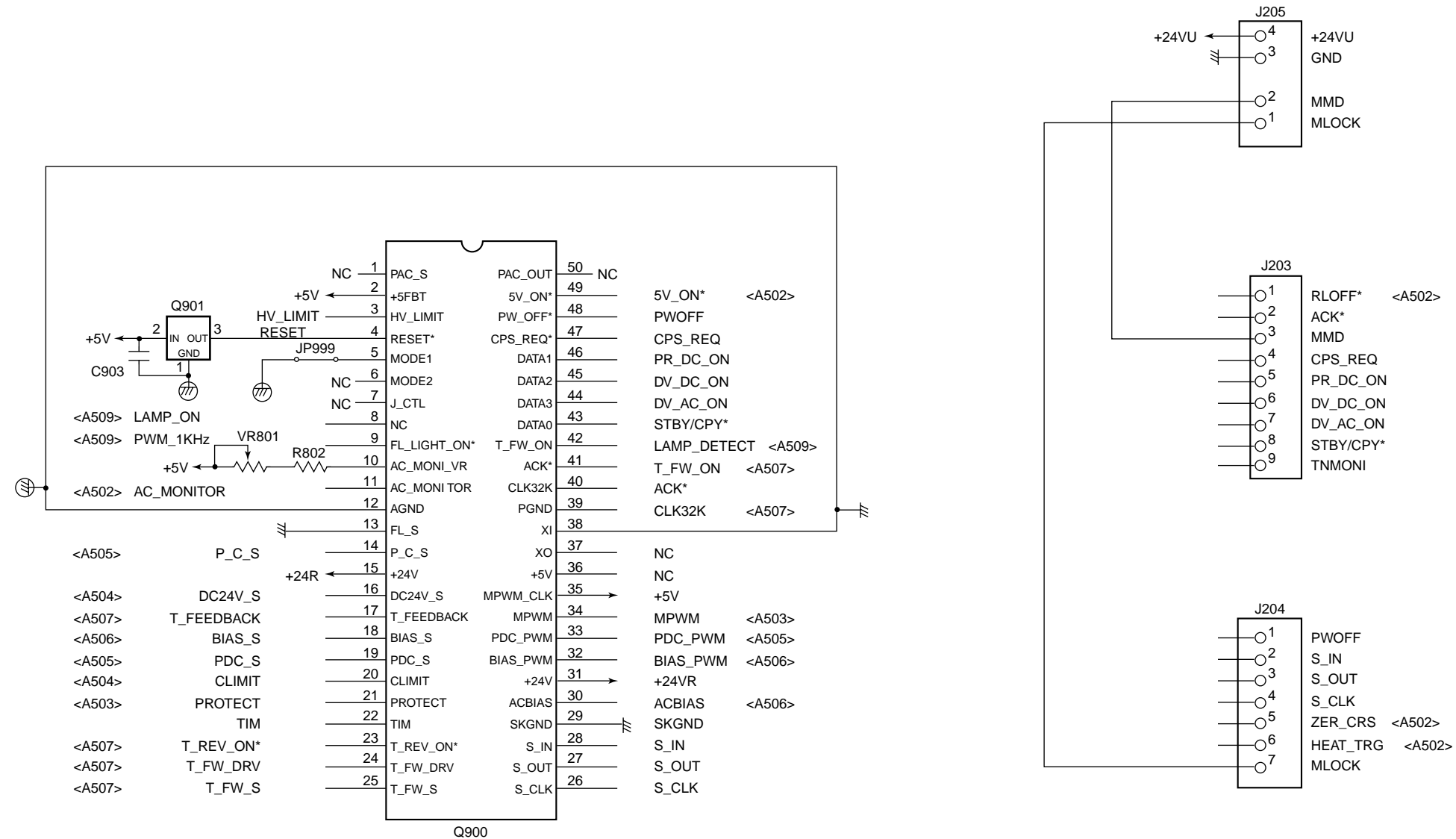

JP999: 220/240V model only

Composite Power Supply Circuit Diagram (8/9)  
[A509]

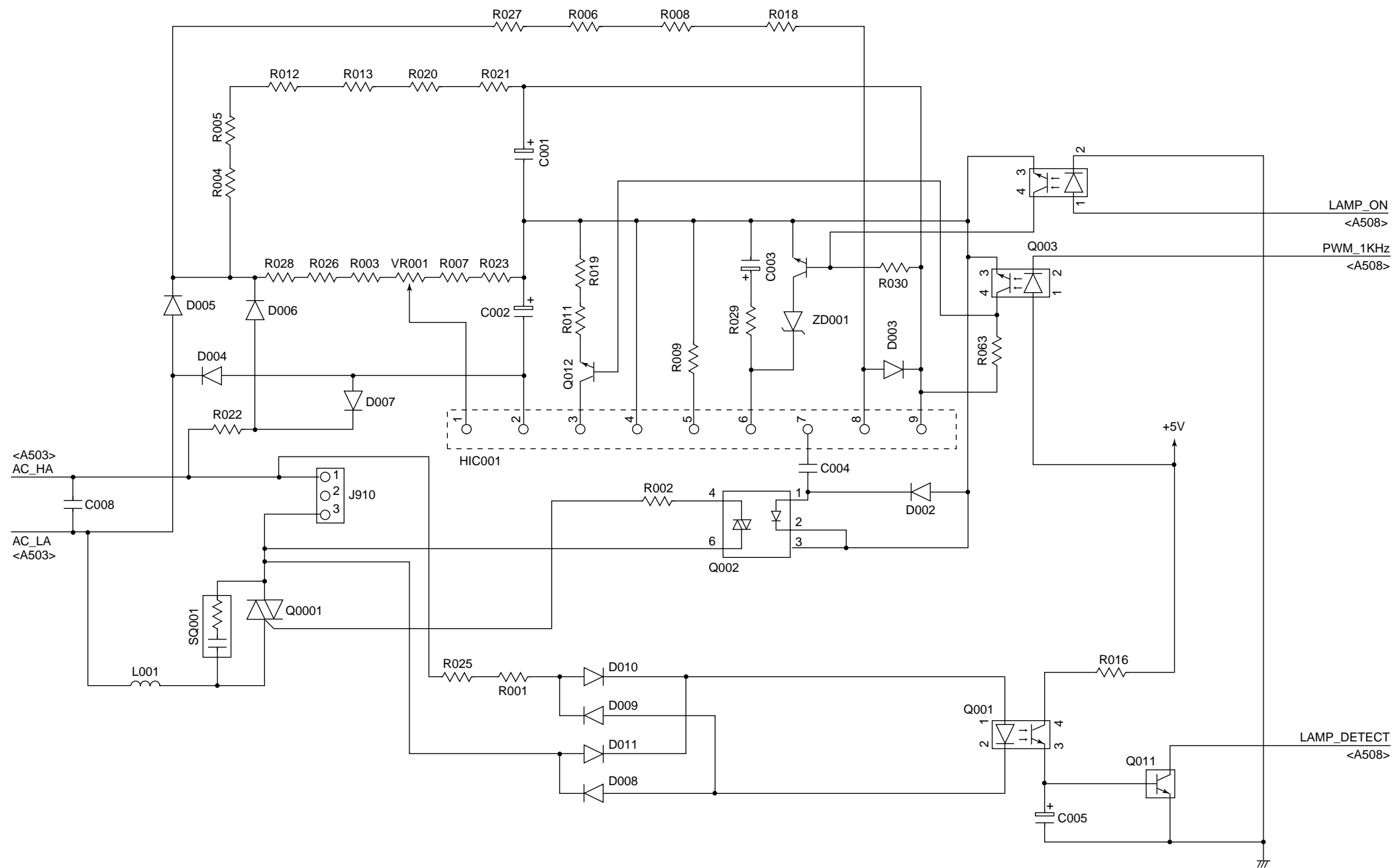

R012, R013, R018, R021: 220/240V model only

# Composite Power Supply Circuit Diagram (9/9) [A510]

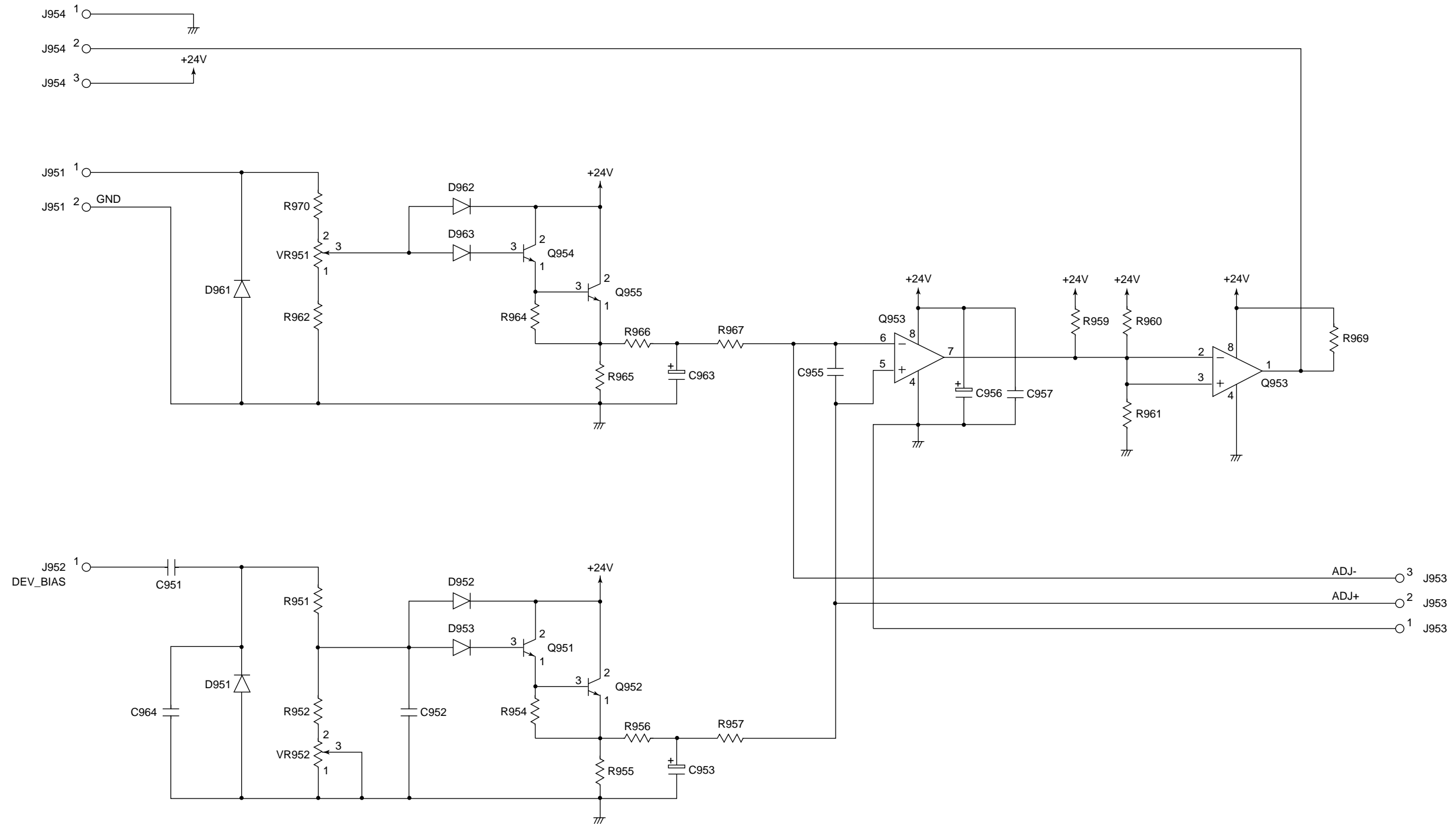

Download Service Manual And Resetter Printer at <http://printer1.blogspot.com>



# G. CONTROL PANEL CIRCUIT DIAGRAM

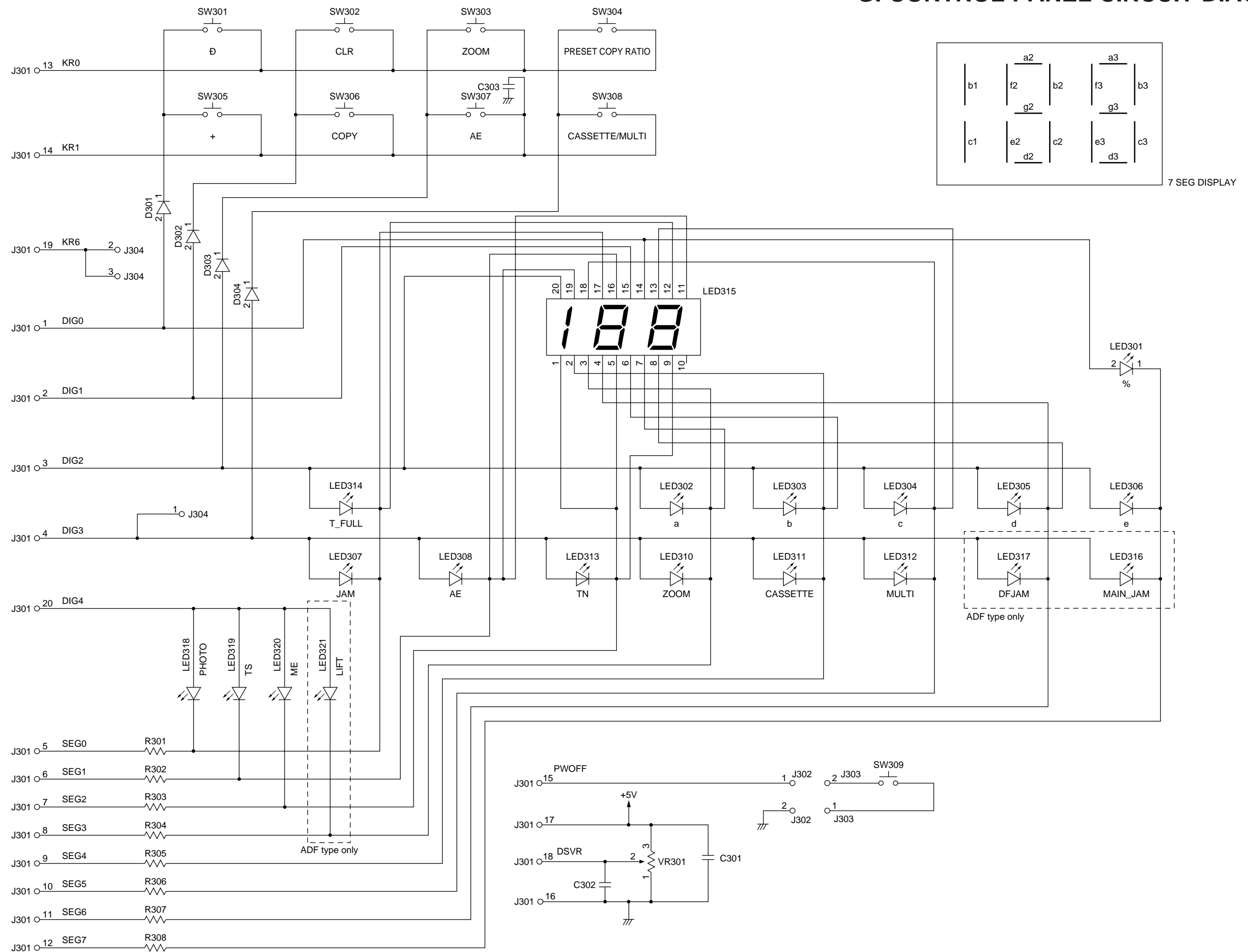



## H. AE SENSOR CIRCUIT DIAGRAM

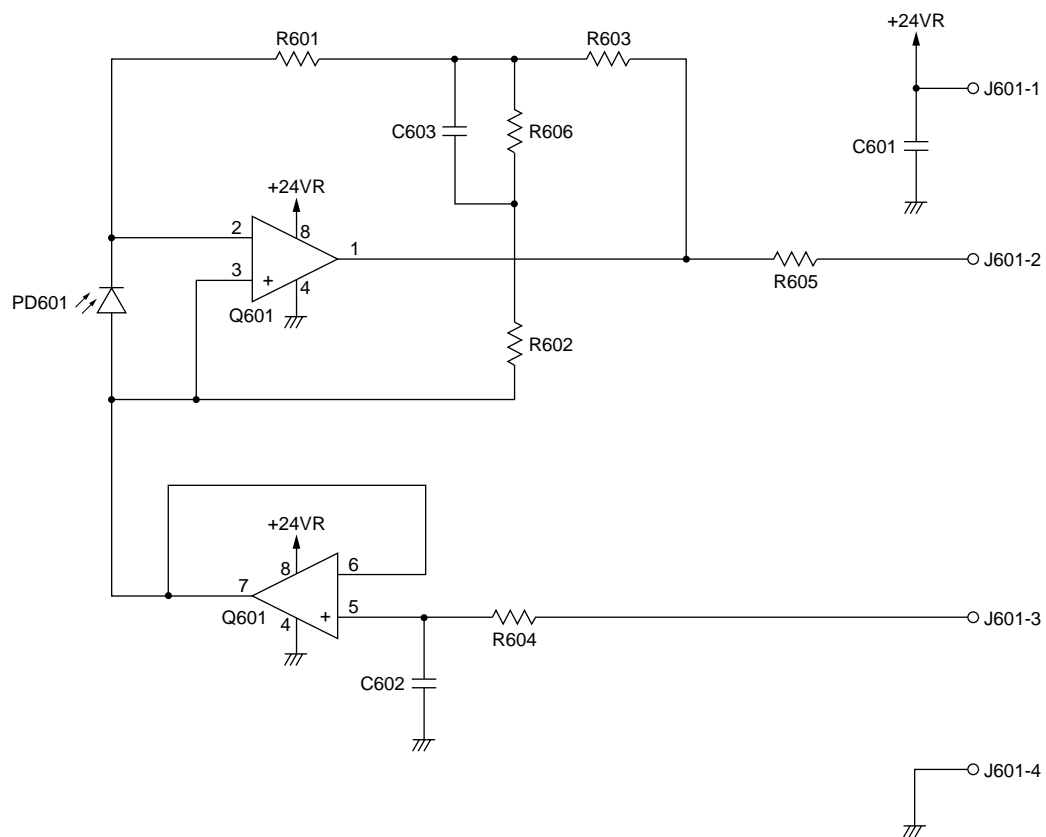

# I. SENSOR CIRCUIT DIAGRAM

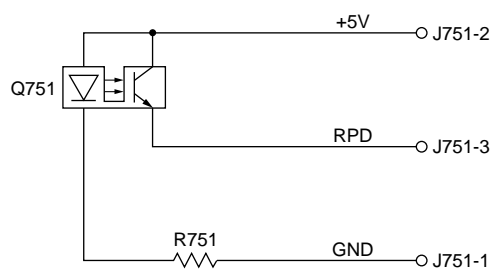



## J. NOISE FILTER CIRCUIT DIAGRAM

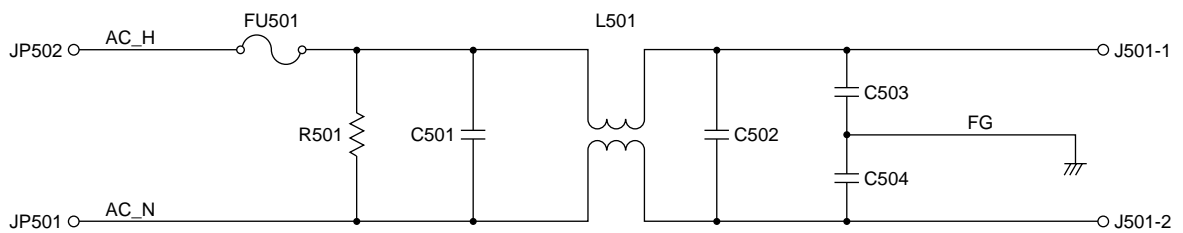

## K. HIGH VOLTAGE CONTACT CIRCUIT DIAGRAM

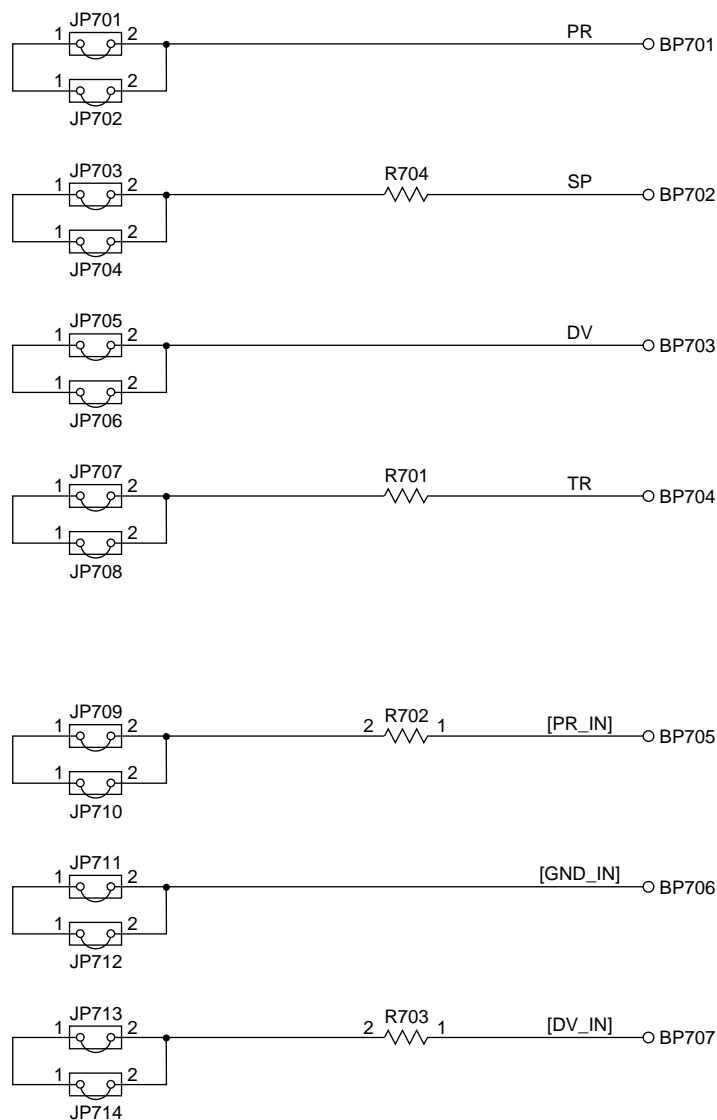

## L. BLANK EXPOSURE (front) CIRCUIT DIAGRAM

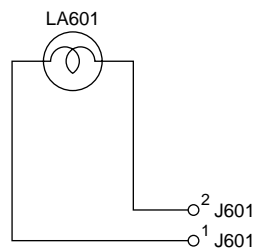

## M. BLANK EXPOSURE (rear) CIRCUIT DIAGRAM

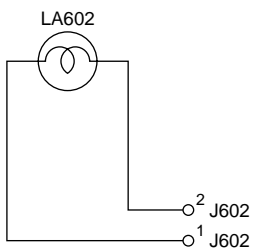

## N. PRE-EXPOSURE CIRCUIT DIAGRAM

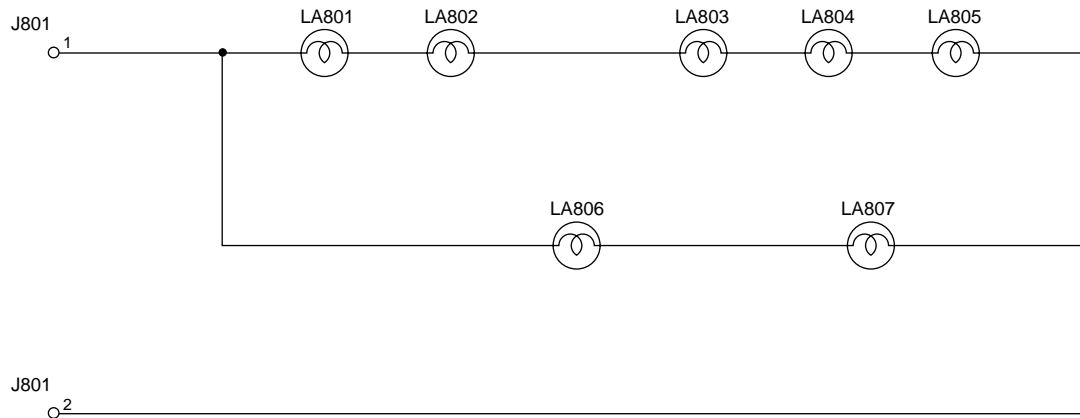

## O. SPECIAL TOOLS

You will need the following special tool(s) in addition to the standard tools set when servicing the machine.

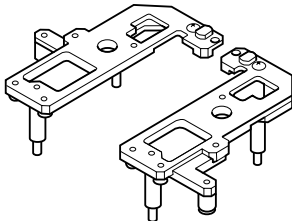
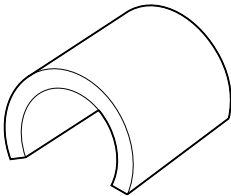
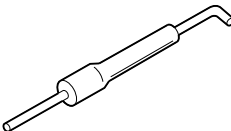
No	Tool	Tool No.	Shape	Rank*	Remarks
1	Mirror positioning tool (pair for front and rear)	FY9-3009		B	For adjusting the distance between the No.1 and No.2 mirrors.
2	Wire clip	FY9-3017		B	For fixing the scanner wire in place while adjusting its tension.
3	Spring gauge	CK-0054		B	For checking the cassette spring pressure Range of measurements: 0 to 1,500g

\*Rank:

A: Each service person is expected to carry one.

B: Each five or so service persons is expected to carry one.

C: Each workshop is expected to carry one.

## P. SOLVENTS/OILS

No.	Name	Uses	Composition	Remarks
1	Alcohol	Cleaning: e.g., glass, plastic, rubber parts; external covers	Hydrocarbon (fluorine family) Alcohol Surface active agent	<ul style="list-style-type: none"> <li>• Do not bring near fire.</li> <li>• Procure locally.</li> <li>• Isopropyl alcohol may be substituted.</li> </ul>
2	Solvent	Cleaning: e.g., metal; oil or toner dirt	Hydrocarbon (fluorine/chlorine family) Alcohol	<ul style="list-style-type: none"> <li>• Do not bring near fire.</li> <li>• Procure locally.</li> </ul>
3	Lubricating oil	Lubricating spring clutch	Mineral oil (paraffin family)	<ul style="list-style-type: none"> <li>• CK-0451 (100cc)</li> </ul>
4	Lubricating oil	Lubricating drive and friction parts, scanner rail	Silicone oil	<ul style="list-style-type: none"> <li>• CK-0551 (20g)</li> </ul>





Prepared by  
Office Imaging Products Technical Support Division  
CANON INC.  
Printed in Japan

REVISION 0 (AUG. 1999) (30359/10317)

5-1, Hakusan 7-chome, Toride-shi, Ibaraki 302-8501 Japan

# Canon



This publication is printed on  
70% reprocessed paper.